



**Project Title:** BIO\_SOS Biodiversity Multisource Monitoring System:  
from Space TO Species

**Contract No:** FP7-SPA-2010-1-263435

**Instrument:**

**Thematic Priority:**

**Start of project:** 1 December 2010

**Duration:** 36 months

## Deliverable No: 5.2

# VHR land cover maps

**Due date of deliverable:** 31-07-2011

**Actual submission date:** 16 December 2011

**Version:** V2

**Main Authors:** Richard Lucas (P11), Brian O'Connor, Sander Mucher (P4), Laure Roupioz, Damien Arvor (P12), Valeria Tomaselli (P1), Maria Adamo(P1), Cristina Tarantino (P1), Vasiliki Kosmidou (P3), Panayotis Dimopoulos (P2), Palma Blonda(P1), Guido Pasquariello (P1).



<b>Project ref. number</b>	<b>263435</b>
<b>Project title</b>	<b>BIO_SOS: Biodiversity Multisource Monitoring System: from Space to Species</b>
<b>Deliverable title</b>	<Deliverable Title>
<b>Deliverable number</b>	<Del no (e.g. D1)>
<b>Deliverable version</b>	D5.2
<b>Previous version(s)</b>	V1
<b>Contractual date of delivery</b>	30 <sup>th</sup> November 2011
<b>Actual date of delivery</b>	16 <sup>th</sup> December 2011
<b>Deliverable filename</b>	D5.2_Final_v2
<b>Nature of deliverable</b>	R = Report
<b>Dissemination level</b>	PU
<b>Number of pages</b>	267
<b>Workpackage</b>	WP5
<b>Partner responsible</b>	P1
<b>Author(s)</b>	Richard Lucas (P11), Brian O'Connor, Sander Mucher (P4), Laure Roupioz, Damien Arvor (P12), Valeria Tomaselli (P1), Maria Adamo(P1), Cristina Tarantino (P1), Vasiliki Kosmidou (P3), Panayotis Dimopoulos (P2), Palma Blonda(P1), Guido Pasquariello (P1)
<b>Editor</b>	Richard Lucas
<b>EC Project Officer</b>	Florence Beroud
<b>Abstract</b>	Provides Very High Resolution (VHR) maps of LCCS categories for four test sites in Italy, Wales and the Netherlands.
<b>Keywords</b>	VHR, land cover maps, habitats, semantic nets

## Signatures

<b>Editor</b>	<b>Responsibility- Company</b>	<b>Date</b>	<b>Signature</b>
Richard Lucas	Editor (P11)	15/12/2011	
<b>Verified by</b>			
Palma Blonda	Deliverable Responsible (P1)	15/12/2011	
Laurent Durieux	WP5 Leader (P12)	15/12/2011	
<b>Approved by</b>			
Palma Blonda	Coordinator (P1)	15/12/2011	
Maria Petrou	QAP Leader (P5)	15/12/2011	

## Table of Contents

1. Executive summary .....	6
2. Introduction.....	7
PART 1 .....	11
A1. Introduction to the representation of expert knowledge, for land cover and habitat mapping, by the use of semantic networks.....	12
A1.1 Modelling the description of geographic objects .....	12
A1.2 Introduction to ontologies .....	20
A1.2.1 Top-Level ontology .....	21
A1.2.2 Framework ontologies .....	21
A1.2.3 Domain ontologies.....	27
A1.2.4 Task ontology .....	30
A1.2.5 Application ontology .....	30
B1. Overview of LCCS categories and GHCs for the test sites .....	31
B1.1 Introduction .....	31
C1. Pre-processing.....	38
C1.1 VHR data .....	38
C1.2 Pre-processing of airborne hyperspectral and LiDAR datasets.....	40
C1.3 Overview of image datasets .....	42
C1.3.1 Italian sites .....	42
C1.3.2 Welsh sites.....	42
C1.3.3 Dutch sites .....	43
D1. Collection of field data for calibration/validation.....	47
D1.1 Italian sites .....	47
D1.2 Welsh sites.....	47
D1.2.1 Cors Fochno.....	47
D1.2.2 Cors Caron.....	53
D1.3 Dutch sites .....	53
D1.4. Summary of available data.....	60
D1.4.1 Italian sites .....	60
D1.4.2 Welsh sites.....	60
D1.4.3 Dutch sites .....	64
D1.5 Critique of field data collection.....	65
E1. Generation of LCCS maps from VHR data .....	67
E1.1 Generation of 1st stage maps.....	67
E1.2 Input layers for Generation of 2 <sup>nd</sup> stage maps .....	68
E1.2.1 Thematic data.....	68
E1.2.2 Key data layers.....	69

## D5.2 VHR land cover maps

E1.2.3	Feature extraction modules .....	75
E1.2.4	Relationships between classes and the importance of semantic nets .....	76
E1.2.5.	Stratified class-specific fuzzy rule-based classification modules .....	79
E1.3	Overview of accuracy assessment procedures.....	80
E1.4	Overview .....	82
F1.	VHR classifications of LC/LU categories in LCCS .....	83
F1.1	Two-stage classifications with a 1 <sup>st</sup> stage based on SIAM™ preliminary spectral mapping. ....	83
F1.1.1	EODHaM 1st stage: SIAM™ preliminary spectral mapping.....	83
F1.1.2	EODHaM 2nd stage for LC/LU mapping. ....	88
F1.1.2.1	Class specific features and data selection .....	88
F1.1.2.2	Hierarchy of Processing Levels .....	99
F1.2	Two-stage classifications to LCCS Level 3 (i.e. Dichotomous stage) with a 1 <sup>st</sup> stage based on e-Cognition spectral segmentation. ....	103
F1.2.1	General approach.....	103
F1.2.2	Site classifications to Level 3 .....	109
F1.2.3	Comparison of approach implemented with eCognition and SIAM.....	112
F1.3	Classifications of life forms, surface aspect and physical status .....	116
F1.3.1	Classifications based on eCognition spectral segmentation.....	117
F1.3.1.1	Template development.....	117
F1.3.1.2	Classification of LCCS categories beyond Level 3.....	127
F1.4	Accuracy assessments for the test sites .....	134
G1.	Discussion .....	135
G1.1	Overview.....	135
G1.2	Ontologies and semantic nets for land cover and habitat class description .....	135
G1.3	LCCS categories as a basis for mapping .....	136
G1.4	Use of single-date versus multi-date multi-spectral imagery and inclusion of hyperspectral and LiDAR data. ....	136
G1.5	Comparison of the SIAM™ and eCognition approach .....	137
H1.	Conclusions .....	139
PART 2	.....	140
A2.	Class description for Le Cesine site .....	141
A2.1	IT4 site .....	141
B2.	Class description for Greek sites.....	231
B2.1	GR1 site.....	231
B2.2	GR2 site .....	246
B2.3	GR3 site .....	255
3.	References .....	265

## 1. Executive summary

Deliverable 5.2 (D5.2), entitled “Habitat Maps from Very High Resolution (VHR) imagery” is a deliverable of WP5 and focuses on the production of Food and Agricultural Organisation (FAO) Land Cover Classification Systems (LCCS) maps from very high resolution (VHR) spaceborne optical remote sensing data, primarily Worldview and Quickbird, and their translation to life forms, surface aspect and physical status. D5.2 consists of two parts and includes:

1. A review of the semantic nets language and descriptors.
2. An overview of VHR spaceborne data available for the BIO\_SOS study sites and the approach to data pre-processing.
3. An overview of field data collected to support the classification of FAO LCCS categories and their translation to General Habitat Categories (GHCs).
4. Land Cover class description in 3D world based on semantic networks, with focus initially on a generalized classification to LCCS Level 3 and, subsequently, on more specific classification of lower level classes.
5. Methods for representing and including semantic nets for the classification of LCCS categories, with a detailed knowledge-based example list provided for the Italian site.
6. The approach to classification based on spectral information as well as derived products (e.g., textural measures, vegetation indices).
7. VHR maps of land covers for the test sites in Italy (Le Cesine), Wales (Cors Fochno but also Cors Caron) and the Netherlands (Ginkelse, Eder heide and Wekeromse Zand).
8. Approaches to assessment of classification accuracy.

The Deliverable has established that consistent classification to LCCS Level 3 categories can be achieved between the four Natura 2000 sites and surrounds using a combination of spectral data and indices and ancillary data layers (e.g., existing cadastral information). However, classification to lower levels of the LCCS is less consistent between sites because of differences in land covers occurring, the uniqueness of some and the different types and dates of the remote sensing data used. Improvements to the classifications are, however, anticipated with the inclusion of data from multi-temporal VHR, hyperspectral sensors and Light Detection and Ranging (LiDAR).

## 2. Introduction

In the BIO\_SOS project, a major objective is to generate maps of land covers based on the Food and Agricultural Organisation (FAO) Land Cover Classification Systems (LCCS) taxonomy from very high resolution (VHR) satellite sensor data, with this based on:

- a) Semantic nets module development for the description of land cover (LC) and land use (LU) classes.
- b) A battery of feature-extraction modules.
- c) Additional information (e.g., ancillary and on-site data).
- d) Stratified land cover class-specific fuzzy rule-based classification modules.

In D5.1, example classifications of LCCS categories were provided for sites in Italy and Wales. For IT4 in Italy, an existing land cover map had been generated as part of the European Project Interreg III-A Greece - Italy 2000-2006 (code I3101001 project) and the land cover classes were translated to LCCS categories and subsequently to GHCs and Annex 1 or EUNIS habitats. In this Deliverable, the classification of LCCS in the area of the Le Cesine Natura 2000 site and surrounds using one summer Quickbird and one autumn Worldview2 scene is presented. Whilst land cover and habitat maps were available for the primary and secondary Welsh sites of Cors Fochno (Figure 2.1) and Cors Caron (Figure 2.2), VHR resolution data had not been acquired for D5.1 at the time of writing. For this reason, maps of LCCS were generated initially for Cors Fochno from SIAM<sup>TM</sup> first stage spectral categories associated with Landsat Thematic Mapper (TM) and Enhanced TM (ETM+) data (acquired in April 2006 and July 2001) and SPOT High Resolution Geometric (HRG) (acquired in November, 2010). By using these data, familiarity with the use of spectral categories in a rule-based classification (developed within eCognition image segmentation and classification software), assignment of landscape units to LCCS categories and the translation of LCCS categories to GHCs were achieved. The importance of including existing ancillary data (digital elevation models (DEMs), Land Parcel Information System (LPIS) field boundaries and OS Mastermap layers representing the extent of infrastructure), particularly when using coarser spatial resolution (e.g., Landsat data), was highlighted. However, such information was itself obtained originally from high (< 5 m) spatial resolution data (e.g., SAR interferometry, aerial photography interpretation) and, to some extent, could be extracted from VHR data (e.g., infrastructure and cadastral boundaries). VHR data were not initially available for the classification, and hence the focus on medium resolution satellite sensor data, but a Worldview image was acquired over Cors Fochno (following tasking) in July 2011 (delivered in November) and subsequently in November 2011. Worldview data were also acquired for the proximal Natura 2000 site of Cors Caron in April 2011 and were therefore evaluated, firstly to assess the use of spring (pre-flush) imagery but also to evaluate algorithms developed for classifying land covers at Cors Fochno and *vice versa*. Hyperspectral EAGLE and LiDAR data had been acquired previously in 2009 and their classification will be reported fully in D5\_4.

For the Netherlands, classification of the two test sites of Ginkelse and Ederheide (Figure 2.3) and Wekeromse Zand (Figure 2.4) had not been undertaken previously but has been performed using VHR Worldview data in this study, primarily to evaluate the approach to classification, initially to LCCS Level 3.

In this Deliverable, the classifications of LCCS categories from these VHR datasets are illustrated.

## D5.2 VHR land cover maps

a)



Figure 2.1. Aerial image of Cors Caron (Tregaron Bog) acquired in December, 2011.

b)



Figure 2.2. Aerial image of Cors Caron (Tregaron Bog) acquired in September, 2011.





Figure 2.3. Aerial image of Ginkelse and Ederheide, heathlands surrounded by forests and agricultural fields on the NP Veluwe, Province of Gelderland, the Netherlands.



Figure 2.4. Aerial image of Wekeromse Zand, with inland drift sands, and rich in lichens, in the Province of Gelderland, the Netherlands.

The Deliverable is divided into two parts. Part 1 outlines the approach to generating maps of LCCS categories) whilst Part B provides a more detailed overview of habitats within Le Cesine and how these can be described in the field and from remote sensing data. Part B was undertaken to partly inform the development of semantic nets in Part 1.

### **PART 1: GENERATION OF LCCS MAPS FROM VHR REMOTE SENSING DATA.**

PART 1 consists of seven sections that outline the approach to generating maps of LCCS categories, with evaluation over the four test sites.

Section A1 provides an overview of ontologies and semantic networks and how they can be used to integrate expertise from the various disciplines within the BIOSOS project in a concise and logical fashion. Ontologies and semantics provide the means to include the interests of all parties concerned in habitat recognition from both the field and remote sensing point of view.

Section B1 provides an overview of the LCCS and GHC categories occurring within the Italian, Welsh and Dutch test sites. Common habitats found at all sites are indicated whilst the unique habitats at each site are also identified and briefly described.

Section C1 contains an overview of the image datasets available for each site. The pre-processing steps for the VHR optical satellite data, prior to classification, are described. For pre-processing, a standard method was adopted to ensure consistency in results between sites. A brief overview of LIDAR and hyperspectral data acquired for the Welsh and Dutch test sites is also provided.

Section D1 describes the collection of field data in Italy, Wales and the Netherlands to support the classification of LCCS categories and to validate outputs. The field data available from previous field campaigns for verification of the current classified results are also described. The section is concluded with a critique of field collection methods and recommendations for future ground support.

Section E1 outlines the approach to the generation of LCCS maps from VHR data, with focus on the use of spectral information (e.g., categories, indices) and derived products. Template semantic nets linking the remote sensing and field-based point of view of geographic objects are illustrated with UML diagrams. The templates presented are initially for the classification to LCCS Level 3 and subsequently of broad landcover/habitat categories, defined within lower levels of the LCCS. In the latter cases, these can be adapted according to specific site characteristics (e.g., in terms of unique habitats).

Section F1 contains a brief review of accuracy assessment methods available to the project, and details the procedures used to estimate the accuracy of the LCCS maps. Indicative estimates of classification accuracy for the maps are provided for Wales and Italy, although significant improvements are anticipated following integration of the time-series datasets and/or hyperspectral and LiDAR data and final estimates will be provided in D5.4.

Section G1 provides a brief discussion of the methods adopted during the deliverable. This section is composed of sub-sections that detail several challenges that arose during the course of the study. The approaches to addressing these challenges in order to achieve the successful and timely delivery of the work are discussed.

Section H1 concludes the study, highlighting several notable achievements of the project deliverable while suggested improvements for future work.

### **PART 2: KNOWLEDGE-DRIVEN LAND COVER AND LAND USE DESCRIPTIONS.**

PART 2 consists of two sections. In the first (A2), and for the Italian site of Le Cesine, the land cover class description in the 3D world from experts in both the natural language and in a semantic network framework is included. Particular focus is on a knowledge-driven land cover and land use class description for the site using the LCCS taxonomy and class-specific semantic descriptions (e.g., IS A, PART-OF) as well as spatial relationships and temporal transitions. In section B2, a knowledge driven class description for two Greek test sites is also provided.

**PART 1**

**GENERATION OF LCCS  
MAPS FROM  
VHR REMOTE SENSING  
DATA.**

## **A1. Introduction to the representation of expert knowledge, for land cover and habitat mapping, by the use of semantic networks**

### **A1.1 Modelling the description of geographic objects**

One major objective of the BIO\_SOS project is to produce land cover and habitat maps based on prior knowledge provided by experts. Two issues are presented. a) who are the experts? And b) how can prior expert knowledge be represented? In a multi-disciplinary project such as BIO\_SOS, experts from various fields, such as ecology, remote sensing, GIS, computer science, geography or image processing are expected to work together, and many issues arise on the way to sharing knowledge. In particular, there are general issues on vocabularies amongst scientific communities and knowledge of other disciplines (for instance, an ecologist may not be aware of the potentialities and limits of the use of remote sensing data for mapping the habitats). To solve these issues, it is necessary to identify a standardized way to represent expert knowledge. In BIO\_SOS, we argue that semantic nets can help. Semantic nets are defined as directed acyclic graphs, consisting of nodes and edges (Grove, 1999), where nodes represent elements of knowledge and edges represent relations between elements of knowledge.

In order to build semantic nets that could be shared between partners, we need to define a) a common formalism for semantic net representation, b) a common model for building the semantic net and c) a common vocabulary for nodes and edges. In other words, it is important to conceptualize the way we represent the land cover and habitat classes we want to map.

In this conceptualization phase, we chose to work with an object approach where nodes are represented by classes corresponding to concepts. Edges are then represented by relationships between those classes. Furthermore, it is possible to include properties, which are attributes of classes. As a standard formalism for representing semantic nets, we used the Unified Modeling Language (UML). UML already includes a standard vocabulary for relationships such as generalization/specialization (is-a), aggregation/composition (part-of) and association (to be labeled) relations. As such it is a useful tool for allowing us to model and convey the semantic nets. A summary of the symbols and terms used in the UML diagrams is shown in Table A1.1 and examples are given in Figure A1.1a and b.

Once the tool has been defined, it is then necessary to consider ways to structure the semantic nets. The idea is to give the keys to any expert (for instance, an ecologist or a remote sensing expert) to describe a land cover class or a habitat.

In BIO\_SOS, a model has been proposed and is introduced in Figure A1.2. The central part of the model is the Geographic Object, whose description is based on three main topics:

- a) A thematic description of the geographic object based on its physical components, such as vegetation, bare soil, water or artificial element.
- b) A spatial dimension describing spatial properties of the geographic object including area, shape and diameter.
- c) Relations describing the existing relation between geographic objects. These relations belong to three main categories: semantic relations (e.g., is-a, part-of), spatial relations (e.g., adjacent, close-to) and temporal relations (e.g., after, before).

## D5.2 VHR land cover maps

Table A1.1: Summary of terms used in class and object diagrams of UML semantic nets

Semantic Relations    
  Spatial Relations    
  Temporal Relations

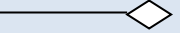
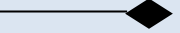
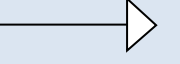
Symbol	Meaning	Type	Explanation	Rules	Use
	Aggregation		No specific constraint between aggregate and elements	PART-OF	When the component has its own existence (it is independent)
	Composition		Strong constraint between composite and components		When the component cannot exist alone
	Generalisation/Specialisation	Single	abstraction is "generalisation", refinement is "specialisation"	IS-A SubClass inherits all the attributes and operations from the SuperClass	When a class object "is a kind of" or "is an" instance of" another class
		Multiple	One sub class can have various super classes and one super classes can have various sub classes		
<u>DATA-OF</u>	Association relation with label			DATA-OF	The initial concepts which can be extracted directly from the data are connected via  The <i>data-of</i> link to the primitives segmented by image processing algorithms.
<u>CON-OF</u>	Association relation with label			CON-OF	The transformation of an abstract description into its more concrete representation in the data (Grove, 1999)

D5.2 VHR land cover maps

Symbol	Meaning	Type	Explanation	Rules	Use
<u>INSIDE</u>	Association relation with label	Spatial	Topological relations	inside, adjacent, cross, overlap, disjoint	See figure below
<u>CLOSE</u>	Association relation with label		Non Topological relations (Qualitative distance and cardinal relations)	Very close, close, commensurate, far, very far, right, left, front, back, right-front, right-back, left-front, left-back, north, south, east, west, northeast, southeast, northwest, southwest.	
<u>BELOW</u>	Association relation with label		Topological relations (3D)	Below, above, front-of, behind	

D5.2 VHR land cover maps

Symbol	Meaning	Type	Explanation	Rules	Use
<u>AFTER</u>	Association relation with label	Temporal	Topological Relations (between intervals)	AFTER	X takes place after Y
<u>BEFORE</u>	Association relation with label			BEFORE	X takes place before Y
<u>MEETS</u>	Association relation with label			MEETS	X finishes when Y starts
<u>OVERLAPS</u>	Association relation with label			OVERLAPS	X finishes after Y starts
<u>STARTS</u>	Association relation with label			STARTS	X starts Y
<u>DURING</u>	Association relation with label			DURING	X takes place during Y
<u>FINISHES</u>	Association relation with label			FINISHES	X finishes Y
<u>IS-EQUAL-TO</u>	Association relation with label			IS EQUAL TO	X is equal to Y

## D5.2 VHR land cover maps

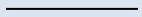
Symbol	Meaning	Type	Explanation	Rules	Use
	Association	Binary	Between 2 classes		When there is no particular relationship between classes.
		N-ary	Between many classes	>2	
		Reflexive	Links a class to itself		
		Multiplicities	Number of objects of one class linked to another class	1	
	0..1			Zero or one	
	M..N			From M to N	
	*or 0..*			Zero to many	
	1..*	1 to many			



D5.2 VHR land cover maps

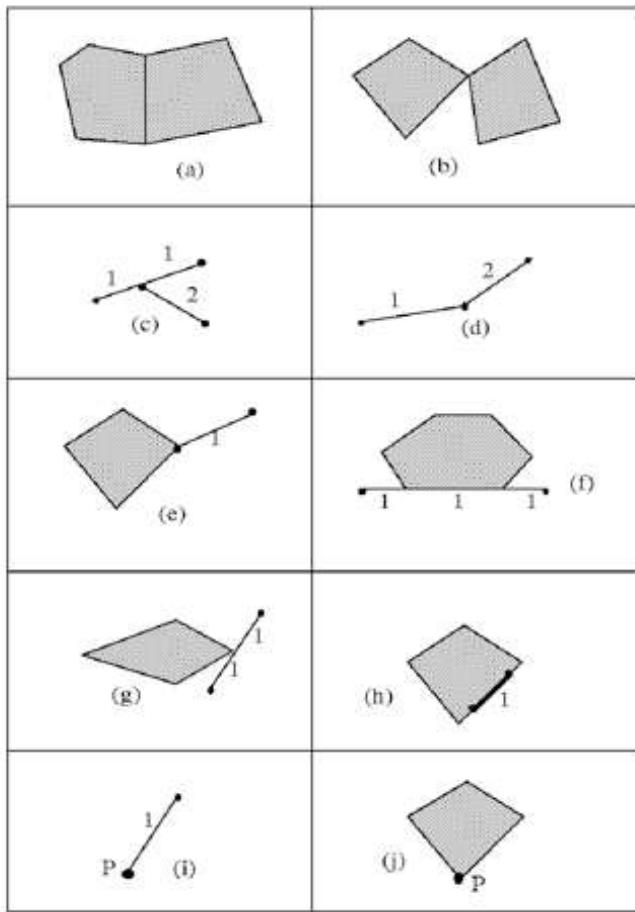

The TOUCH relationship between two areas (a,b), two lines (cd), a line and an area (e-h) a point and a line (i) and point and an area (j)

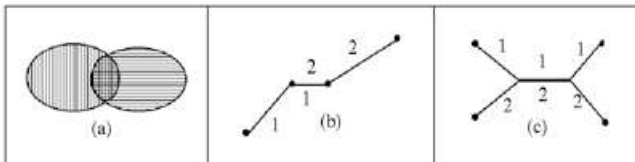

The OVERLAP relationship between two areas (a) and two lines (b, c)

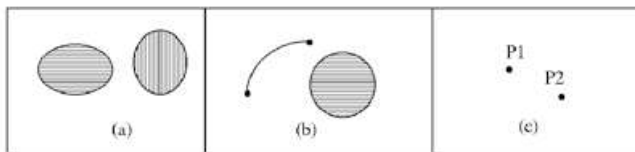

The DISJOINT relationship between two areas (a), a line and an area (b) and two points (c)

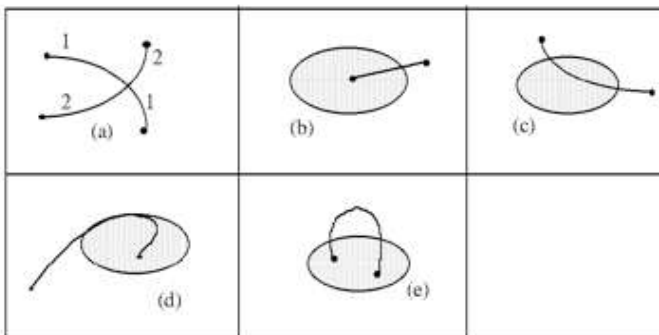

The CROSS relationship between two lines (a), a line and an area (b-e).

Figure A1.1 a) Topological relationships

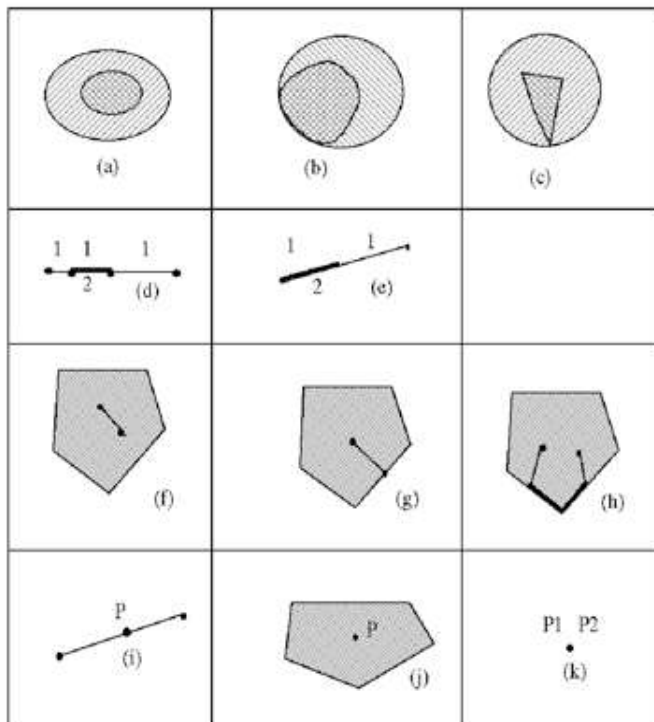

The IN relationship between two areas (a-c), two lines (d,e) a line and an area (f-h), a point and a line (i) a point and an area (j), two points (k)

Figure A1.1 b). Topological relationships (further details can be found in D5.1)

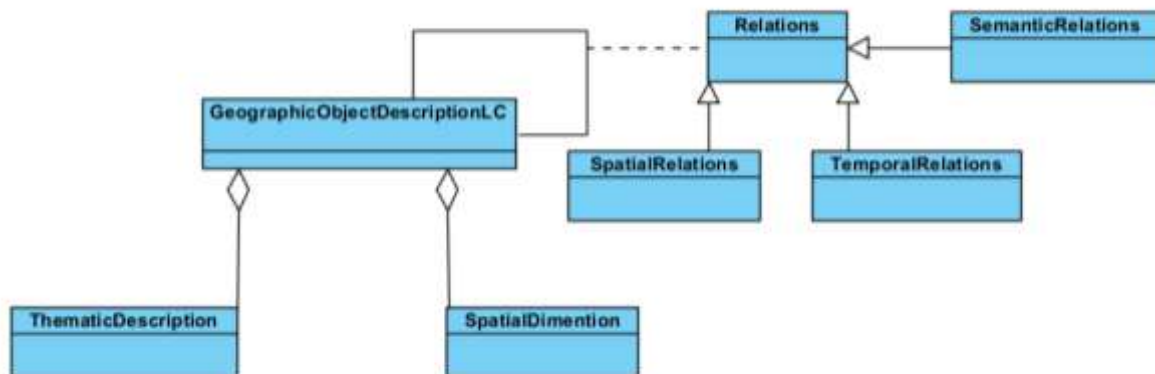

Figure A1.2. Proposed model for describing geographical objects in BIO\_SOS.

Furthermore, the diagram introduced in Figure A1.2 needs to be completed (Figure A1.3). First, the geographic object may be single or complex (i.e., composed of various single objects). For instance, the olive grove is composed of various olive trees, which can be individually observed. Each single geographic object can then be described based on the same model (Figure A1.2). Second, even single objects may be composed of various physical components. For instance, reedbeds are composed of vegetation (reeds) located in water. While describing the thematic of a geographical object, we then decided to distinguish the core physical component and its associated context. The core element is considered as a sufficient and necessary condition to describe the element. For instance, observing various olive trees in a geographical object is sufficient to identify that the geographic object is an

olive grove. However, this description can then be improved by adding information on its context, such as identifying if the inter-tree space is composed of bare soil or grassland.

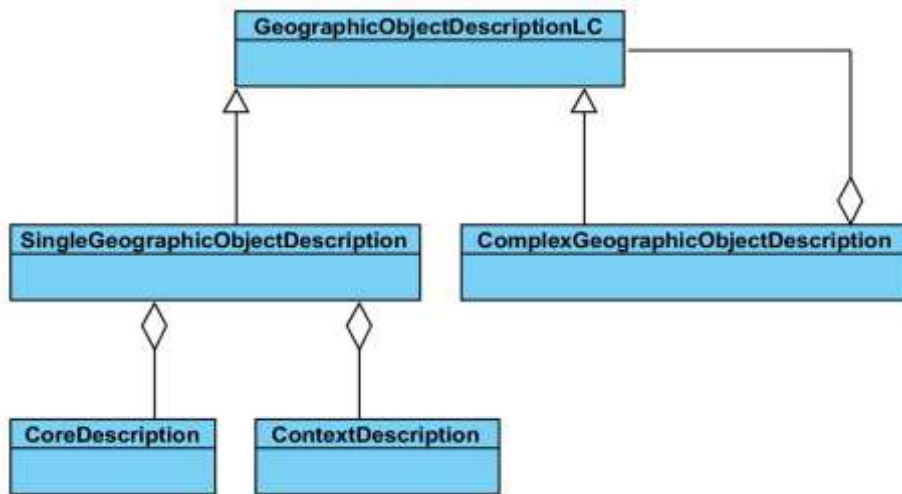

Figure A1.3 Description of single and complex geographic objects.

This model can be used to describe both geographic objects observed in the real world conditions and in the remote sensing image (Figure A1.4). In other words, the model will be used to describe the same geographic objects (e.g., an olive grove) from different point of views. On this basis, bridges can be built between the real world and the remote sensing concepts, implying that relevant vocabularies will have to be defined and agreed by both communities.

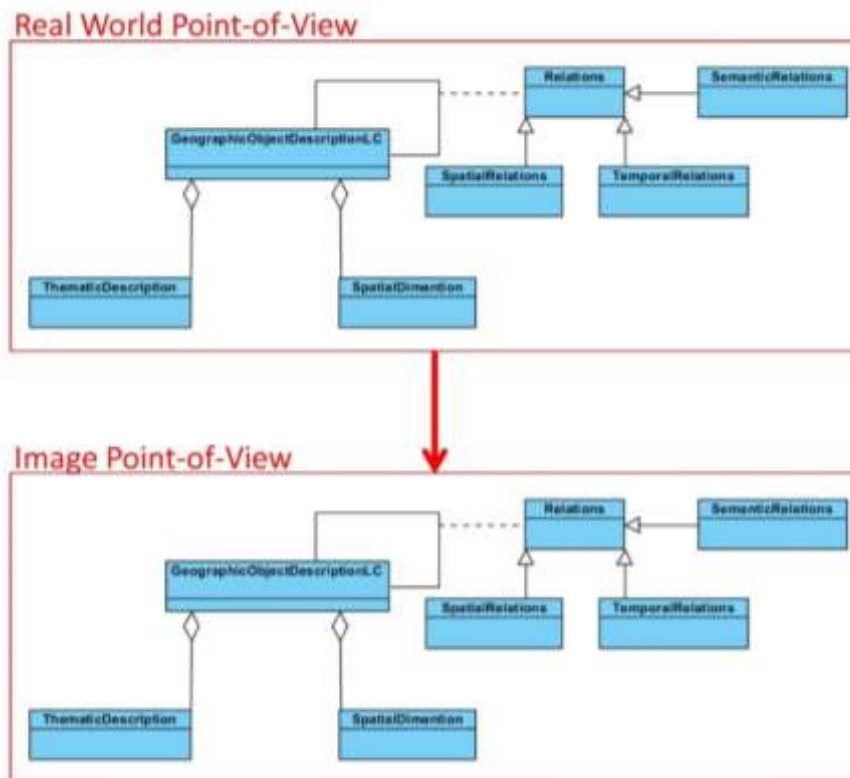

Figure A1.4 Building the bridge between the real-world and the image point-of-view.

Combining this knowledge represents a significant challenge. An issue also remains on the vocabulary to be used for describing the geographic objects from both the real world and remote sensing points of view. In other words, the challenger is to define the concepts to be used in the main description boxes introduced in Figure A1.2: thematic, spatial dimension, spatial relations, temporal relations and semantic relations.

In BIO\_SOS, we argue that the identification of such vocabularies should be assisted by the inclusion of *ontologies*.

## A1.2 Introduction to ontologies

Ontologies are formal, explicit specification of a shared conceptualization (Gruber, 1995), which defines the concepts, relationships and other distinctions that are relevant for modeling a domain (Gruber, 2009). In that sense, the ontologies are quite close to semantic nets defined in the previous section. However, ontologies have several main advantages:

- a) Ontologies can be linked to higher-level ontologies
- b) Concepts in ontologies are rich in semantically defined relations to other concepts
- c) Ontologies can be specified in machine-interpretable languages that allow automatic inferences.

Since ontologies can be linked to higher-level ontologies, it means that these are actually interconnected according to a defined architecture. Five types of ontologies are defined (Figure A1.5):

- a) Top-level ontologies define very general concepts such as space, time, matter, object, event and action independent of a specific domain or problem.
- b) Framework ontologies define very general concepts dependent on a specific domain (Earth and environment, geographic norms, etc)
- c) Domain ontologies describe the terminology of a specific domain
- d) Task ontologies describe a task or activity, such as image interpretation
- e) Application ontologies describe the terms that are on the one hand dependent on a domain and on the other hand on a very specific task in an applicative context.

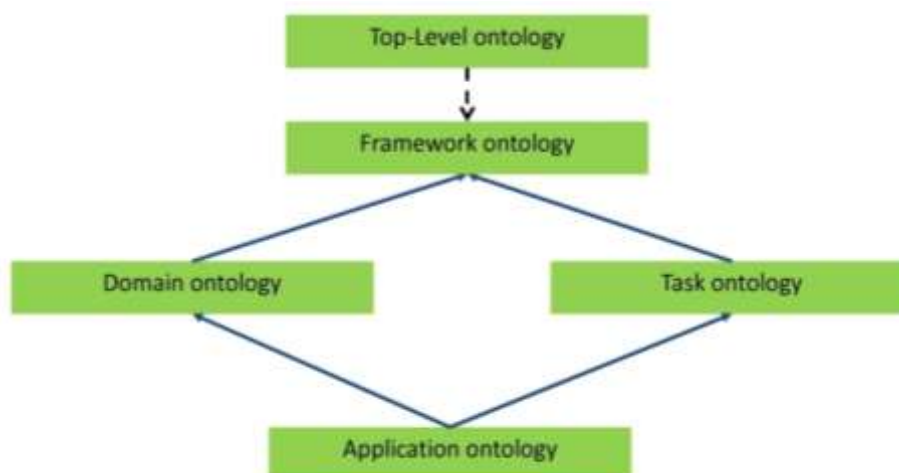

Figure A1.5. Architecture of ontological levels.

The primary challenge is to understand how to fill these ontologies. The following sections introduce several ontologies and the way these can be built within BIO\_SOS.

### A1.2.1 Top-Level ontology

Various top-level ontologies exist (Mascardi et al., 2007) and a number are available for use within BIO\_SOS. For instance, the Semantic Web for Earth and Environmental Terminology (SWEET) proposed by NASA is written in the OWL ontology language and is publically available. These ontologies are highly modular and 6000 concepts in 200 separate ontologies are included. These consist of nine top-level ontologies or concepts (Figure A1.6; <http://sweet.jpl.nasa.gov/>). The concepts introduced in the SWEET ontology are divided into orthogonal dimensions or facets (Raskin and Pan, 2005). It means that concepts are identified independently before being linked in order to build more complex compound concepts. For instance, the "air temperature" is a compound of the substance "air" and the property "temperature". Then, unifying ontologies (such as phenomena) are transversal and based on concepts from the vertical ontologies. This structure provides a scalable solution to a growing knowledge base (Raskin and Pan, 2005). It can then be extended, following the same structure, to domain ontologies, as proposed by Tripathi and Babaie (2008) for the hydrogeology domain.

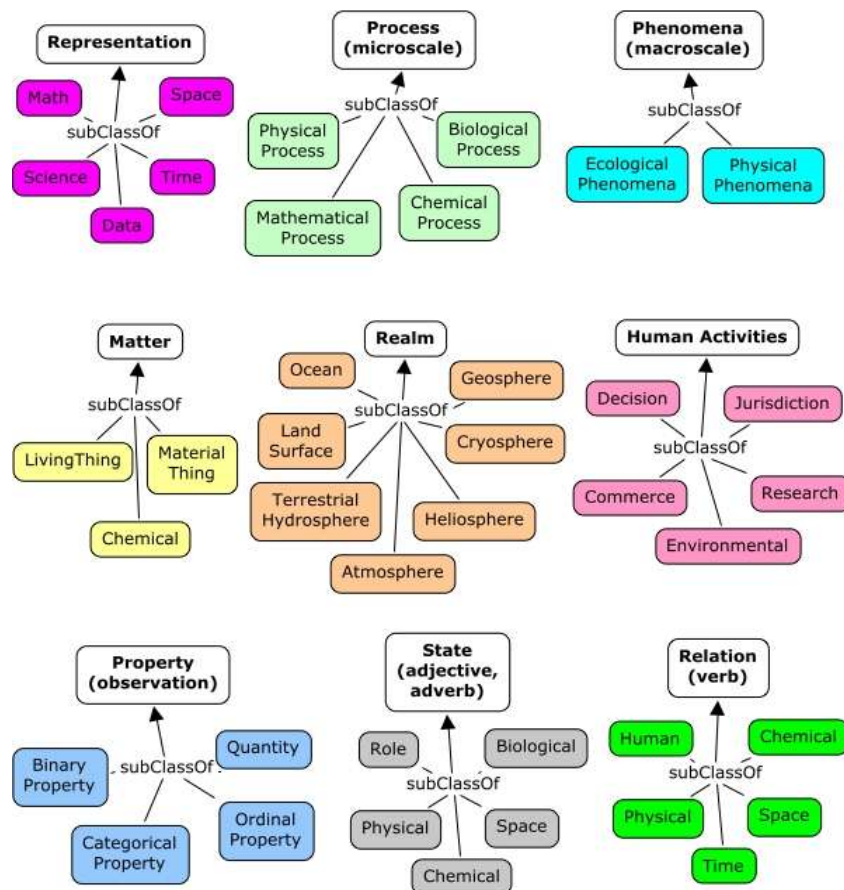

Figure A1.6. SWEET top-level ontologies.

### A1.2.2 Framework ontologies

Framework ontologies are built to define the general concepts and relations to be used in the lower level ontologies. These ontologies need to be constructed with a common architecture and linked directly with domain ontologies. Main framework ontologies should deal with concepts involving :

**Thematic: vegetation, bare soil, artificial and water:** The AGROVOC thesaurus proposed by the FAO introduces concepts linked to the agricultural domain (<http://aims.fao.org/website/AGROVOC-Thesaurus/sub>). The thesaurus consists of a structured vocabulary where concepts are linked together by simple relations such as "broader than", "narrower than" or "related to". An example of such terms for vegetation is introduced in Figure A1.7 and provides a basis of concepts to be included in ontologies (involving much more complex relations) that will then be connected to the top-level ontology. The SWEET ontology can also be used at this step, as illustrated for the description of water bodies (Figure A1.8). It is noteworthy that these ontologies may then be improved by including concepts from the LCCS and GHC nomenclatures. For instance, a land cover class from LCCS can be identified as sub-class of a concept introduced in the AGROVOC thesaurus. Moreover, at this level, a framework ontology on ecology should be introduced. It must include information on the hierarchy of ecological systems. In his PhD, Múcher (2009) defines this hierarchy of ecological systems as follows: "Ecological systems are characterized by diversity, heterogeneity and complexity (Wu and David, 2002) and need a multi-scale or hierarchical approach to their analysis, monitoring, modeling and management (Hay et al., 2002). Wu and David (2002) advocate the Hierarchical Patch Dynamics Model (HPDM), which provides a powerful framework for breaking down complexity and integrating pattern with process (Wu and Marceau, 2002). HPDM uses a spatially nested patch hierarchy, which consists of local ecosystems, local landscapes and regional landscapes. Jongman and Bunce (2000) propose a more comprehensive hierarchy, which is adapted here into the following hierarchical levels:

- a) *Biosphere*: as the global sum of all ecosystems including its interactions with the lithosphere, hydrosphere and atmosphere;
- b) *Biogeographic regions*: or environmental zones such as the Atlantic region which is dominated by a specific climate regime;
- c) *Landscape*: For example, Atlantic lowlands dominated by clayey sediments and arable land such as the Dutch polders, characterized by a dominant biome and land use pattern at the regional scale. This is similar to the regional landscape of Wu and David (2002).
- d) *Ecosystem* or *habitat* such as a fresh water habitat. In principle, these ecosystems or habitats consist of relatively homogenous vegetation-soil complexes and resemble the local ecosystem in HPDM;
- e) *Species* and *ecotypes*: These different levels will then be linked to spatial scale issues from the Earth Observation (EO) systems. The landscape level is of particular interest and must be more developed in a domain ontology.

**Spatial dimension:** Norms for describing spatial characteristics must be integrated and hence this dimension consists on geometrical and morphological concepts. Norms from the OGC (Open GIS Consortium) should be prioritized to keep link with international standards.

**Relations:** At a framework level, this requires identifying main norms for describing spatial and temporal relations. For instance, for spatial relations, main norms involve concepts from the 9-intersection model (Egenhofer and Herring, 1991) or the RCC8 model (Randell et al., 1992). Both norms involve three main categories of spatial relations: topological relations, distance relations and direction relations (Figure A1.9). Of note is that:

- a) Temporal relations still need to be developed but main concepts from Allen (1983) should be used.
- b) Semantic relations involve the main relations included in UML (i.e., is-a, part-of, association link).

## D5.2 VHR land cover maps

**Earth observation:** This ontology should introduce main terms to link to EO (e.g., sensors, data, spectral bands). Further work is needed to establish whether this type of ontology already exists from (e.g., within CNES, ESA, NASA or GEO).

## D5.2 VHR land cover maps

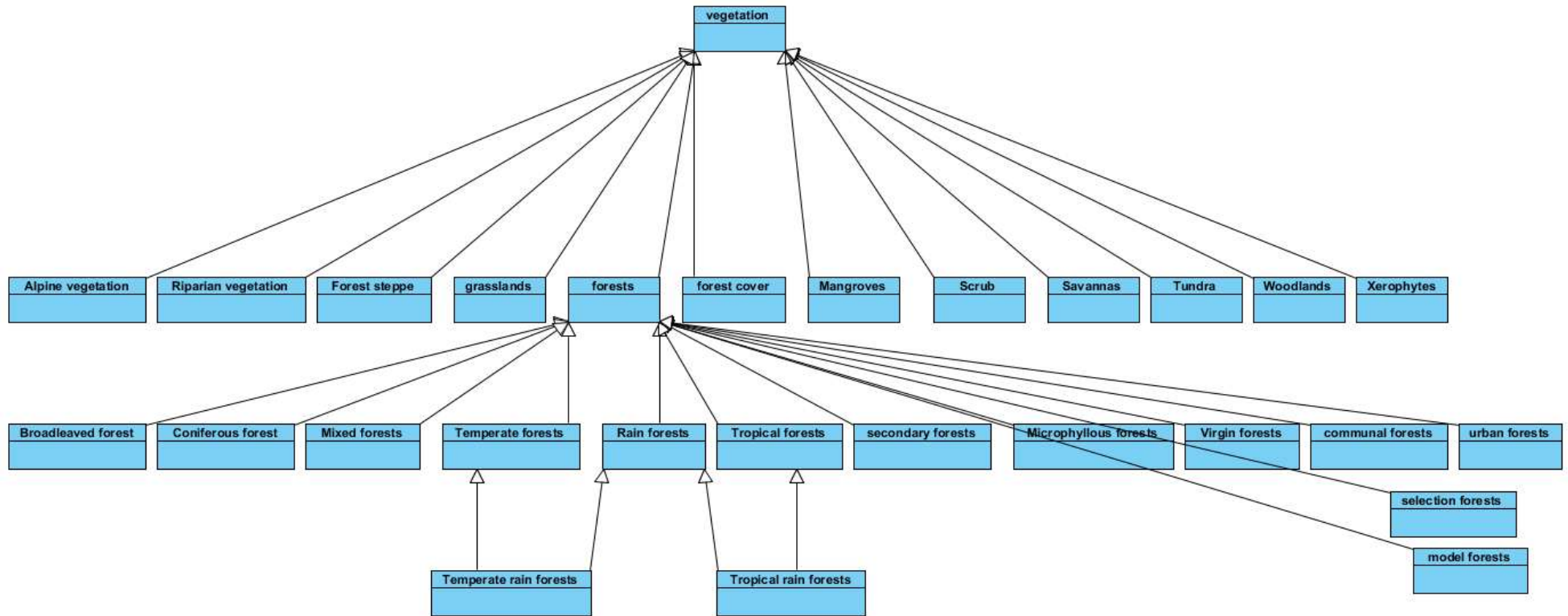

Figure A1.7. Framework ontology for vegetation extracted from AGROVOC (incomplete ontology, only the forests concept is partially described here).



## D5.2 VHR land cover maps

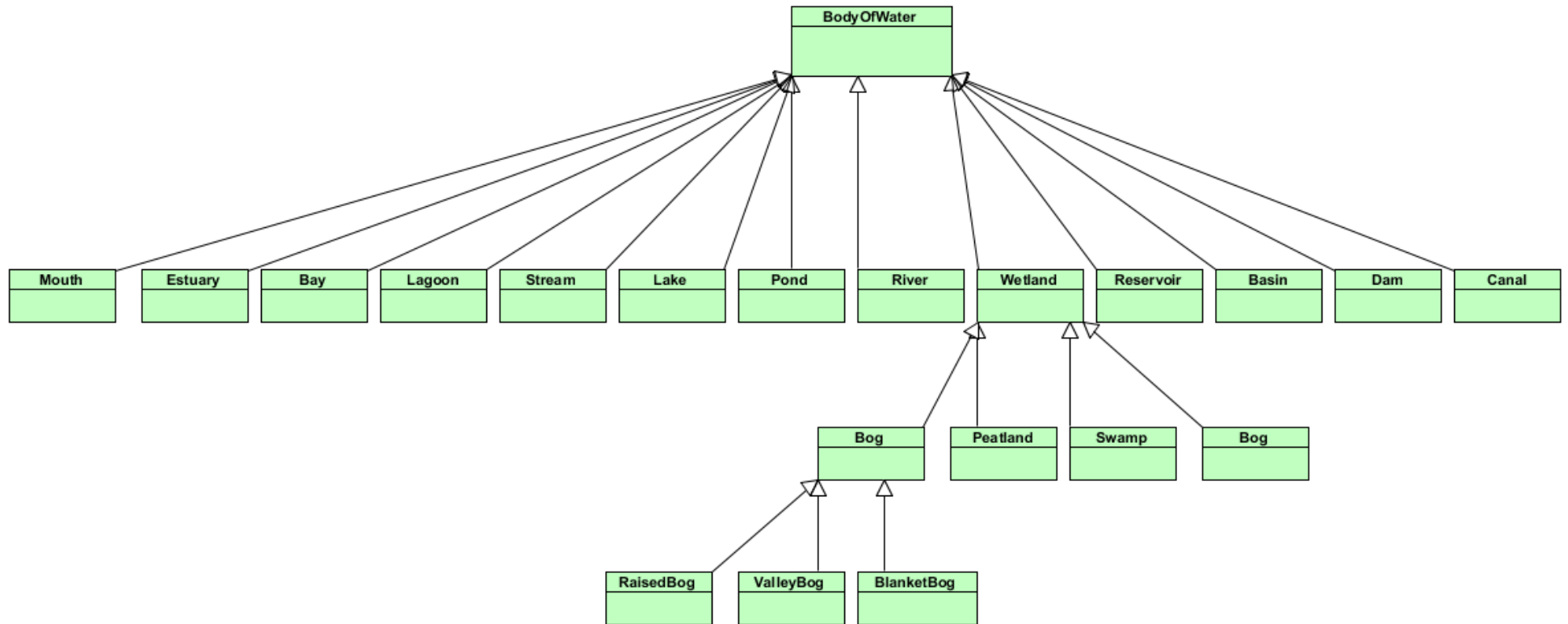

Figure A1.8. Framework ontology for water bodies extracted from SWEET (incomplete ontology, only the wetland concept is partially described here).

## D5.2 VHR land cover maps

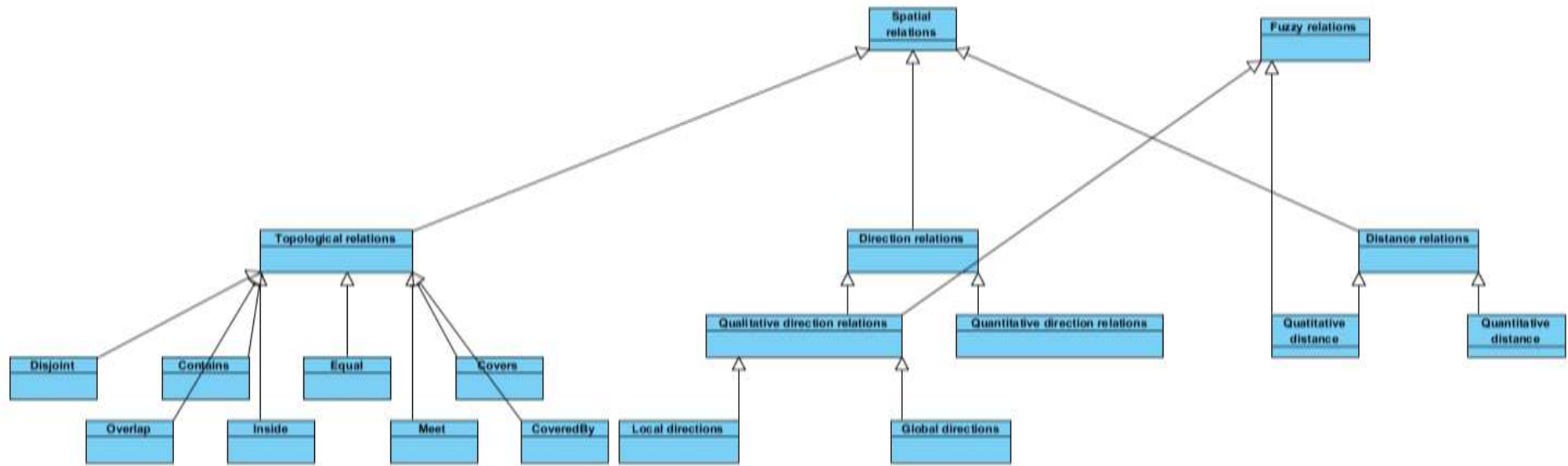

Figure A1.9. Framework ontology for spatial relations extracted from bibliography (mainly Egenhofer's work).

### A1.2.3 Domain ontologies

Domain ontologies should include more details on concepts introduced in the framework ontologies. In particular, the more detailed terms may consist of introducing the attributes used to describe the general concepts. These terms should be extracted from the nomenclatures used in BIO\_SOS (i.e., LCCS, GHC).

**Thematic:** The case of vegetation illustrates this point. Terms proposed by LCCS or GHC for describing vegetation may differ. For instance, the LCCS description of vegetation is based on concepts such as herbaceous, lichens/mosses and woody vegetation (Figure A1.10). In GHC, the description is more complex involving biological types from the Raunkiaer classification (Figure A1.11). Thus, it is necessary to introduce these concepts in the domain ontologies for vegetation description and then find some correspondences. The same approach should be applied for other thematic information types such as water, bare soil and artificial elements. Moreover, the landscape ecological level must be described here, including corresponding biodiversity indicators.

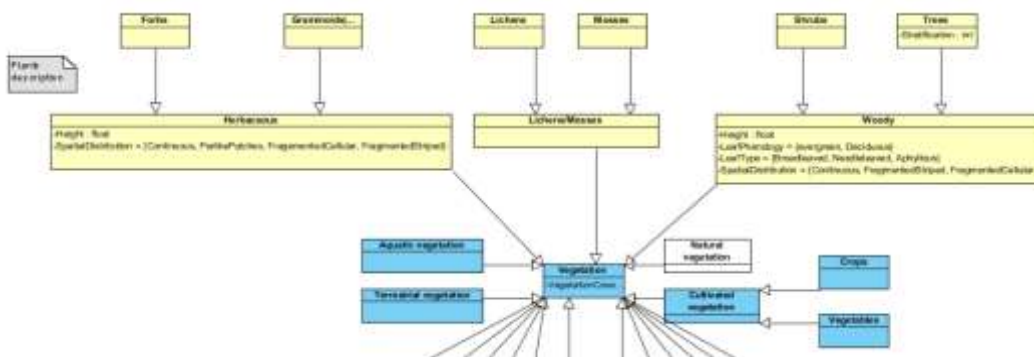

Figure A1.10. LCCS terms (in yellow) used to describe vegetation.

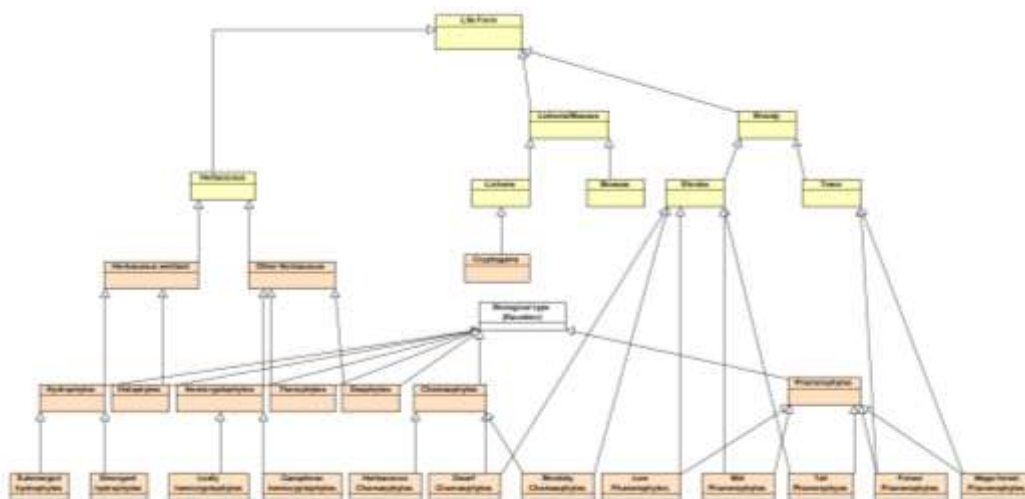

Figure A1.11. GHC terms to describe vegetation and correspondences with LCCS.

## D5.2 VHR land cover maps

The same type of diagram has also been built for the description of water (Figure A1.12).

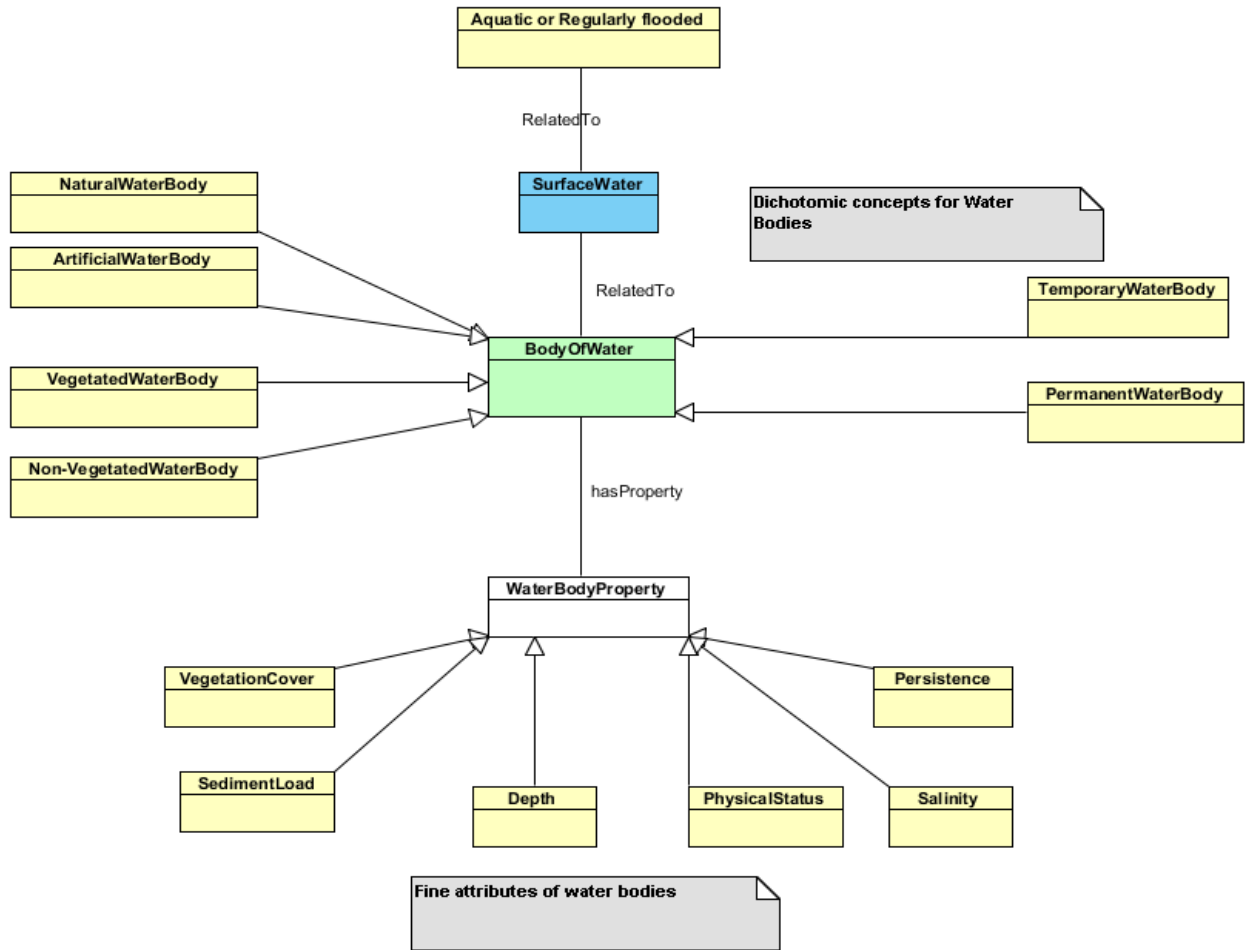

Figure A1.12. Domain ontology for water bodies (green terms from SWEET, Blue term from AGROVOC, yellow terms from LCCS and GHC)

**Spatial dimension:** Natural language terms for describing the spatial dimension of geographic objects should be introduced (Figure A1.13).

## D5.2 VHR land cover maps

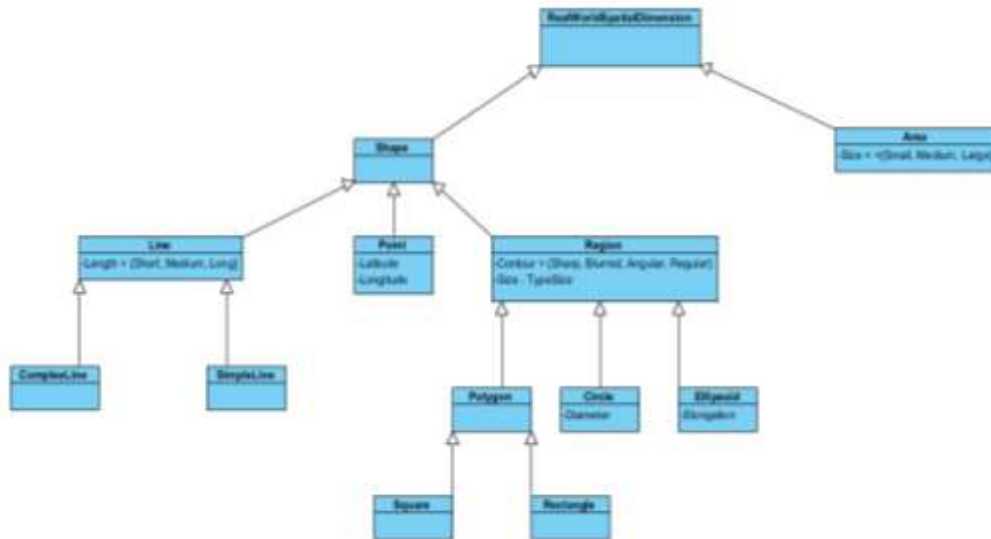

Figure A1.13. Diagram of concepts to be used to describe spatial dimension.

**Relations:** Once norms for spatial and temporal relations have been identified, one should think in the best way to make it useful for the final end-users. For instance, it is necessary to identify the natural-language terms that can help an ecologist to describe the spatial relationships between different land covers. This kind of work has been undertaken by Clementini et al. (1993) who proposed 5 terms to describe all topological relations between regions, lines and points. They also proposed terms to describe distances and directions (Figure A1.14). While describing the spatial relations between geographical objects, experts should integrate concepts from Naïve Geography as proposed by Egenhofer and Mark, (1995), which claims that the space is two dimensional.

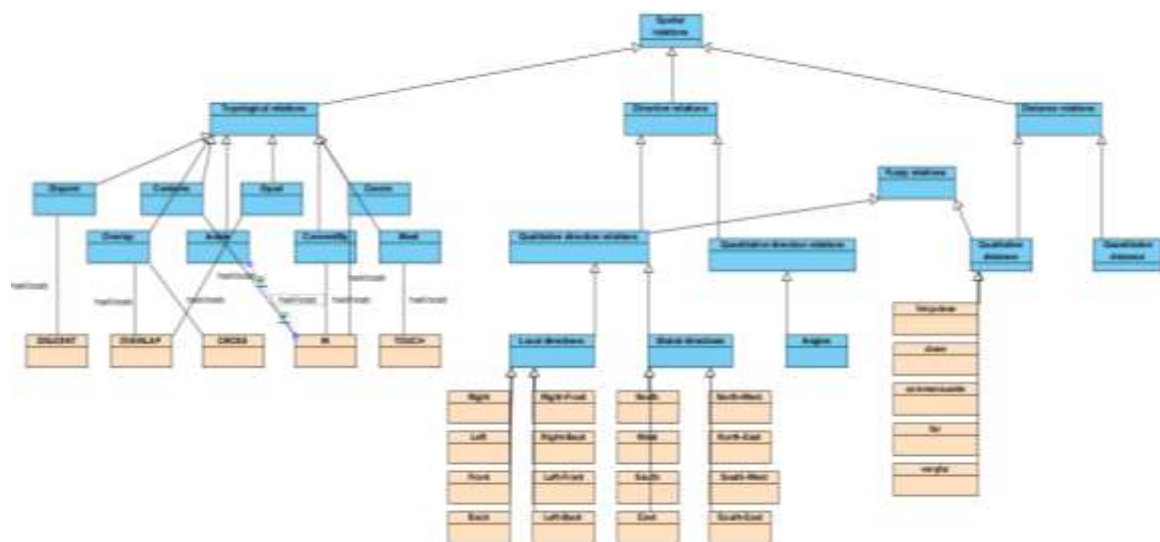

Figure A1.14. Domain ontology for spatial relations including natural language terms (in orange) proposed by Clementini et al. (1993) and linked to the framework ontology (blue).

The terms to describe temporal relations have not been defined at this moment. However, we might mention here the interesting proposal from Allen (1983) regarding 13 temporal relations between 2 intervals.

Finally, semantic relations should be improved at a domain level to include relations between classes that are neither spatial nor temporal. For instance, particular relations to build the bridges between the real world and the image point of views should be identified. In Growe (1999), terms such as concrete-of and data-of were introduced and defined as follows: “The transformation of an abstract description into its more concrete representation in the data is modelled by the concrete-of relation, abbreviated con-of. [...] The initial concepts which can be extracted directly from the data are connected via the data-of link to the primitives segmented by image processing algorithms.”

**Remote sensing:** After EO has been introduced at the framework level, more specific terms from the remote sensing community must be introduced at the domain level. For instance, concepts such as spectral signature, texture, structure and indices should be defined.

### **A1.2.4 Task ontology**

Task ontologies describe a task (or activity) and correspond to those informed by the remote sensing expert and link 2D ‘real world’ ontologies with the 2D representation in the image. The ontology consists of describing operators that can be used to operationalize the process of mapping an image based on a real world class description. For this purpose, since the methodology is to be developed within eCognition software, we listed all operators available. The idea is then to check which operators can be used in order to analyze, for example, spatial relations, spatial dimensions and spectral signatures.

### **A1.2.5 Application ontology**

In the application ontologies, both real world and remote sensing semantic nets for different land cover classes are introduced. At this step, we mainly defined real world semantic nets for various classes in Wales and in Italy (see next sections). In the future, it will be necessary to complete them with the remote sensing semantic net point of view.

## B1. Overview of LCCS categories and GHCs for the test sites

### B1.1 Introduction

For the Italian, Welsh and also the Dutch test sites, an overview of the LCCS categories and the GHCs is given in Tables B1.1 to B1.3

Within the Italian site of Le Cesine, many of the natural and semi-natural habitats are associated with aquatic environments (i.e., wetlands) and forests/shrublands although less extensive areas of grasslands and herbaceous vegetation occur. In Wales, the primary aquatic habitats are the active bog (which occurs at both Cors Fochno and Cors Caron) and the saltmarsh, whilst in the Netherlands these are limited to small lakes, ponds and rivers. The Dutch study area is a very dry area on sandy soils and is affiliated with National Park Veluwe, which is the largest end moraine in the Netherlands. The undulating sandy landscape was created during penultimate glacial period, about 150,000 years ago. The final landscape of alternating drifting sand areas, heathlands and dry forests were created by a long history of intensive land use (starting from Celtic fields in Iron Age). Drifting inland sands caused by anthropogenic overexploitation were a serious threat and were battled around 1900 by massive forest plantations. Since then the drifting sand area has severely diminished. However, the inland drifting sand areas of the Veluwe are amongst the most extensive in Europe. The distinguishing feature of Le Cesine is that annual vegetation is more prominent, which is attributable to the Mediterranean climate, and broad-leaved trees and shrubs are evergreen as opposed to deciduous, although the latter do occur. Orchards of olive trees are typical only to Le Cesine whilst croplands are more intensive in the Netherlands. Wales is the least cultivated in terms of crops, with permanent grasslands for sheep and cattle grazing predominating. The threats to the environment in Italy include urban expansion and agricultural intensification. Wales include shrub encroachment but also potential seawater intrusion and nitrogen deposition. The pressures on the biodiversity of the nutrient poor ecosystems in the Netherlands are high due to intensive agriculture, causing nitrogen deposition, which creates a process of moss encroachment by *Campylopus introflexus*, grass encroachment by *Molinia caerulea*, shrub encroachment by *Rubus fruticosus* spp. and *Prunus serotina*, and tree encroachment by *Pinus sylvestris* and *Betula pendula*.

The LCCS categories that are common to all three sites are artificial and water categories (paved roads, urban areas and artificial and natural waterbodies) as well as rainfed needle-leaved tree crops, although the tree species differ. In Wales, Larch (e.g., *Larix decidua*) is a common plantation species but is deciduous rather than evergreen needle-leaved species. The greatest commonality in LCCS categories, as expected, is between the northern European countries of Wales and the Netherlands.

The differences in the LCCS categories occurring complicate their classification from high resolution (HR) and VHR resolution data and particularly the generation of consistent methods for the mapping at lower levels in the hierarchy (e.g., to lifeforms). However, at all sites, the classification to Level 3 of the LCCS can be achieved by simply focusing on discriminating surfaces that are primarily vegetated or non-vegetated, terrestrial or aquatic and cultivated, artificial or natural/semi-natural. Once these areas have been defined, the classification of life forms can take place within these pre-defined areas but is necessarily site or region specific.

D5.2 VHR land cover maps

Table B1.1 a) LCCS categories and General Habitat Categories, Le Cesine, Italy.

Cat.	LCCS Code Modifier	Description	GHC	LCCS		HABITAT: ANNEX 1/EUNIS
				LCCS code used for classification	Environmental Attributes	
A11	A3	Herbaceous crops	CUL/CRO or URB/VEG or URB/GRA or HER/LHE or HER/THE or HER/HCH or HER/GEO	A3.A5		X/I.3
A11	A1.B1.C1.D1.W7.A8.A9.B3	Monocultured fields of rainfed evergreen needle-leaved tree crops (plantations).	URB/TRE or TRS/TPH/EVR/CON or TRS/FPH/EVR/CON	A1.A8.A9.W7		X/G3.F1
A11	A1.B1.C1.D1.W8.A7.A9.B4	Monoculture fields of rainfed broad-leaved tree crops orchards (olive groves)	CUL/WOC or URB/TRE	A1.A7.A9.W8		X/G2.91
A12	A1.A4.A10.B3.D1.E2.B9	Broad-leaved deciduous medium/high closed shrubland (thickets)	URB/TRE or TRS/MPH/DEC or TRS/TPH/DEC	A1.A4.D1.E2		X/F5.51
A12	A1.A4.A10.B3.D2.E1.B9	Needleleaved evergreen medium/high closed shrubland (thickets)	URB/TRE or TRS/MPH/EVR/CON or TRS/TPH/EVR/CON	A1.A4.D2.E1		2250/B1.63
A12	A1.A4.A11.B3.D1.E1.B10	Broad-leaved evergreen open dwarf shrublands	URB/VEG or TRS/DCH/EVR or TRS/SCH/EVR or TRS/LPH/EVR	A1.A4.D1.E1	O3.M213.N12-AR	X/F6.2C
A12	A1.A4.A10.B3.D1.E1.B9	Broad-leaved evergreen medium/high closed shrubland (thickets)	URB/TRE or TRS/MPH/EVR or TRS/TPH/EVR		O3.M213.N12-LP	5330/F5.55
					O3.M233.N12-LP	X/F5.514
A12	A2.A6.A11.B4.E5.B12.E6	Open Perennial Medium T all Grassland	HER/CHE or URB/GRA	A2.A6.E6		2110/B1.31
A12	A2.A5.A11.B4.E5.A13.B13.E7	Open (40-(20- 10)%) annual short forbs	URB/GRA or HER/THE or HER/LHE or HER/HCH or HER/GEO or weak TRS/DCH or weak TRS/SCH	A2.A5.E7		2230/B1.48
					O3.M233.N3.N12-LP	6220/E1.313
A12	A2.A5.A11.B4.E5.B13.E7	Open annual short forbs	URB/GRA or HER/THE or HER/LHE or HER/HCH or HER/GEO or weak TRS/DCH		O3.M233.N3.N12-AR	1210/B1.1



## D5.2 VHR land cover maps

			or weak TRS/SCH			
A12	A2.A5.A10.B4.E5.B12.E7	Closed annual medium/tall forbs	URB/GRA or HER/THE or HER/LHE or HER/HCH or HER/GEO		O3.M233.N12-AC	X/E1.6
A24	A2.A5.A13.B4.C2.E5.B13.E7	Open annual short herbaceous vegetation on temporarily flooded land	URB/GRA or HER/EHY or HER/SHY-FLO or HER/HEL or HER/SHY/LEA	A2.A5.E7	R1.O3.M233	3170/C3.421
					R3/R2.O3.M213.N2.N12-SC	1310/A2.51
					R3/R2.O3.M213.N2.N12-SC	1310/A2.55
A24	A1.A4.A12.B3.C2.D3.B10	Aphyllous closed dwarf shrubs on temporarily flooded land	URB/VEG or TRS/SCH/NLE or TRS/LPH/NLE or TRS/DCH/NLE	A1.A4.D3		1420/A2.526
A24	A2.A6.A12.B4.C2.E5.B11.E6	Perennial closed tall (3-0.8m) grasslands on temporarily flooded land	URB/GRA or HER/EHY or HER/SHY or HER/HEL	A2.A6.E6	R2/R3.O3.M213.N12-SC	1410/A2.522
					R1.O3.M233.N12-HS	7210/D5.24
					R2/R3.O3.M233.N12-HS	X/D5.1
					R2/R3.O3.M233.N12-SC	X/D5.2
A24	A2.A6.A12.B4.C2.E5.B12.E6	Perennial closed medium-tall (0.8-0.3m) grasslands on temporarily flooded land	URB/GRA or HER/EHY or HER/SHY or HER/HEL		R1/R2.O3.M233	X/C2
A24	A2.A5.A16.B4.C1.E5.A15.B12.E6	Perennial sparse medium tall herbaceous vegetation on permanently flooded land	URB/GRA or HER/EHY or HER/SHY-FLO or HER/HEL or HER/SHY/LEA	A2.A5.E6		1150/X03

Table B1.1 b) LCCS categories and General Habitat Categories, Le Cesine, Italy.

Cat.	LCCS Code Modifier	Description	GHC	HABITAT: ANNEX 1/EUNIS
B15	A1.A3.A7.A8	Paved road(s)	URB/ART-ROA	X/J4.2
B15	A1.A4.A13.A17	Scattered industrial or other areas	URB/NON	X/J2.1
B28	A1	Natural waterbodies, flowing (ocean/sea)	SPV/AQU/SEA	X/A7.3

## D5.2 VHR land cover maps

Table B1.2 a) LCCS categories and General Habitat Categories, Cors Fochno, mid Wales.

Cat.	LCCS Code Modifier	Description	GHC
A11	A3.A4.B1.B5.C1.D1.D9_B4	Permanently cropped area: Graminoid crops	CUL/CRO or URB/GRA
A11	A1.B1.B5.C1.D1.D9_A8.B4	Permanently cropped area with rainfed needle-leaved tree crops (plantations).	CUL/WOC or URB/TRE or TRS/TPH/(EVR, DEC)/CON or TRS/FPH/(EVR,DEC)/CON
A11	A1.B1.B5.C1.D1.D9_A7.B4	Permanently cropped area with rainfed broad-leaved tree crops (plantations).	CUL/WOC or URB/TRE or TRS/TPH/DEC or TRS/FPH/DEC
A12	A1.A3.A10.B2.C2.D1.E2.B5	Broad-leaved deciduous fragmented high trees	URB/TRE or TRS/TPH/DEC or TRS/FPH/DEC
A12	A1.A4.A11.B3.C2.D1.E2.B14	Broad-leaved deciduous medium to high shrubland	URB/TRE or TRS/MPH/DEC, or TRS/TPH/DEC
A12	A1.A4.A11.B3.C2.D1.E1	Broad-leaved Evergreen Fragmented Shrubland single layer. Heathland (uplands)	TRS/SCH/EVR
A12	A2.A6.A10.B4.C1.E5_B12.E6	Closed Perennial Medium T all Grassland (e.g., <i>Molinia/Juncus</i> )	HER/CHE
A12	A2.A6.A11.B4.XX.E5_A12.B12.E6	Open ((70-60)-40 %) Perennial Medium T all Grassland (e.g., <i>Eriophorum</i> )	HER/CHE
A12	A2.A6.A10.B4.C2.E5_B13	Closed short grassland	HER/CHE
A12	A2.A5.A10.B4_B11	Closed medium tall forbs (3.0-0.8 m)	HER/LHE
A12	A2.A5.A10.B4_B12	Closed medium tall forbs (0.8-0.3 m)	HER/LHE
A24	A1.A4.A20.B3.C1.D1.E1 .F2.F4.F7.G4_C4	Closed to Open Broad-leaved Evergreen Shrubs with Herbaceous Vegetation on Permanently Flooded Land (Persistent) (Active Bog)	TRS/DCH/EVR or TRS/SCH/EVR or TRS/LPH/EVR, or TRS/MPH-EVR HER/EHY/HEL/SHY-FLO/LEA)
A24	A2.A6.A12.B4.C1.E5_B11.C4.E6	Perennial closed tall grassland on permanently flooded land (persistent)	HER/HEL
A24	A2.A6.A13.B4.C1_B13.C5	Open short grassland on permanently flooded land (with daily variations) (Unmanaged <i>Saltmarsh</i> )	HER/HEL

## D5.2 VHR land cover maps

Table B1.2 b) LCCS categories and General Habitat Categories,  
Cors Fochno, mid Wales.

<b>Cat.</b>	<b>LCCS Code Modifier</b>	<b>Description</b>	<b>GHC</b>
B15	A3_A8	Paved road(s)	URB/ART
B15	A3_A10	Railway(s)	URB/ART
B15	A4_A13	Urban areas	URB/ART/NON
B16	A3_A7	Bare rock	SPV/ROC
B16	A6.B6	Shifting Sands.Saturated Parabolic Dunes	SPV/SAN
B16	A6_A12	Stony loose and shifting sands	SPV/STO
B16	A5_A13	Very stony bare soil and unconsolidated material(s)	SPV/STO/GRV
B27	A1.B1.C2.D1.A5	Clear shallow artificial waterbody (Standing)	SPV/AQU
B27	A1.B1.C1_A4	Turbid Deep to Medium Deep Artificial Perennial waterbodies (Flowing)	SPV/AQU
B27	A1.B1.C1_A5	Deep to Medium Perennial Artificial Waterbodies (Standing)	SPV/AQU
B28	A1.B1.C1_A5	Deep to Medium Perennial Natural Waterbodies (Standing)	SPV/AQU
B28	A1.B3_A4.B6	Tidal Area (Flowing); Surface Aspect (sand)	SPV/AQU(TID)
B28	A1_A4	Natural waterbodies, flowing (ocean/sea)	SPV/AQU/SEA

## D5.2 VHR land cover maps

Table B1.3 a) LCCS categories and General Habitat Categories, the Netherlands.

Cat.	LCCS Code Modifier	Description	GHC
A11	(A3.)A4.B1.B5.C1.D1.D9	Permanently cropped area Graminoid crops	HER/CHE or HER/LHE/CHE
A11	(A3.)A4.B1.B5.C1.D1.D9-B4-S7	Permanently cropped area Graminoid crops, Crop Type: Fodder	CUL/CRO
A11	(A3.)A5.B1.B5.C1.D1.D9-B4-S4	Permanently cropped area Non- Graminoid crops, Crop Type: Roots and Tubers	CUL/CRO
A11	(A3.)A5.B1.B5.C1.D1.D9-B4-S9	Permanently cropped area Non- Graminoid crops, Crop Type: Industrial Crops	CUL/CRO
A11	(A3.)A5.B1.B5.C1.D1.D9-B4-S3	Permanently cropped area Non- Graminoid crops, Crop Type: Cerals	CUL/CRO
A11	(A3.)A5.B1.B5.C1.D1.D9-B4	Permanently cropped area Non- Graminoid crops	CUL/CRO
A11	A1.B1.B5.C1.D1.D9-W8	Permanently Cropped Area with small sized field of rainfed tree crops, crop cover: Orchards	CUL/WOC
A12	A3.A10.B2.C1.D1.E2.F2.F6.F7.G 3.F1-B5F9G8	Broad-leaved Deciduous high trees with open high shrubs	TRS/FPH/DEC
A12	A3.A10.B2.C1.D2.E1.F2.F6.F7.G 3.F1-B5F9G8	Needle-leaved evergreen high trees with open high shrubs	TRS/FPH/CON
A11	A6.A11	Vegetated Urban Area(s) / Park(s)	URB/TRE
A11	A6.A11	Vegetated Urban Area(s) / Park(s)	URB/TRE
A11	A6.A13	Vegetated Urban Area(s) / Lawn(s)	URB/GRA
A11	A2-A6	Extraction site	URB/NON
A11	A6.A13	Vegetated Urban Area(s) / Lawn(s)	URB/GRA
A12	A4.A10.B3.C1.D1.E1.F1-B10	Broad-leaved Evergreen Dwarf Thicket, Single Layer	TRS/SCH or TRS/LPH
A12	A4.A10.B3.C1.D1.E1.F1-B10	Broad-leaved Evergreen Dwarf Thicket, Single Layer	TRS/SCH or TRS/LPH
A12	A6.A10.B4.C2.XXXXF1-B12	Interrupted closed medium tall grassland, single layer	HER/CHE
A24	A6.A12.B4.C3.XXXXF1-B11	Closed Tall grassland on waterlogged soil	HER/HEL
A24	A3.A12.B2.C1.D1.E2.F1	Mixed medium high trees on permanently flooded land (persistent)	TRS/TPH or TRS/FPH
A12	A6.A10.B4.C1.XXXXF1-B12	Closed medium tall grassland, single layer	HER/CHE or HER/LHE/CHE
A11	A1.B1.B5.C1.D1.D9-W8	Permanently Cropped Area with small sized field of rainfed tree crops, crop cover: Orchards	CUL/WOC
A11	A1.B1.B5.C1.D1.D9-W8	Permanently Cropped Area with small sized field of rainfed tree crops, crop cover: Orchards	CUL/WOC
A12	A2.A6.A10.B4.C2.E5_B13	Closed short grassland	HER/CHE

## D5.2 VHR land cover maps

Table B1.3 b) LCCS categories and General Habitat Categories, the Netherlands.

<b>Cat.</b>	<b>LCCS Code Modifier</b>	<b>Description</b>	<b>GHC</b>
B27	A1.B1C1.D1-A4	Clear deep to medium deep artificial perennial watrebodies (flowing)	SPV/AQU
B15	A4_A13	Urban areas	URB/ART
B15	A4-A12A15	Medium density industrial and or other areas	URB/ART or URB/ART/GRA or URB/ART/TRE
B15	A3-A7	Road(s)	URB/ART
B15	A4-A13A17	Scattered Urban Areas(s)	URB/ART
B16	(B16).A6	Loose and shifting sands	SPV/SAN

## C1. Pre-processing.

### C1.1 VHR data

For the Italian, Welsh and Dutch sites, the available VHR imagery available are listed in Table C1.1. For Le Cesine in Italy, both Worldview II and Quickbird imagery were available, with these covering two seasons (spring and autumn). Worldview II imagery were also acquired over Cors Fochno in July, 2011 but the acquisition window was extended to November, 2011 to allow a pair of images acquired over different seasons to be obtained. The image was successfully acquired at the end of the tasking period (mid November) providing a suitable time-series although only the November image was considered in this deliverable. An April Worldview II scene was available over Cors Caron. For the Netherlands, a Worldview II scene was acquired in June, 2011.

Table C1.1. VHR data available for the Italian, Welsh and Dutch sites

Site	Imagery	Acquisition date
Le Cesine, Italy	Quickbird	June, 2009
	Worldview-II	October, 2009
Cors Fochno, Wales	Worldview-II	July, 2011
	Hyperspectral EAGLE	November, 2011
	LiDAR	July, 2009
Cors Caron, Wales	Worldview-II	April, 2011
Veluwe, Netherlands	Worldview-II	June, 2011
	Hyperspectral AHS-160	October, 2007
	CHRIS-PROBA	October, 2007

The Worldview-II data were provided as orthorectified products in UTM projection. Calibration to radiance was undertaken using published coefficients (Table C1.2) and the formula:

$$L\lambda_{pixel,band} = \frac{(a * DN)}{b} \quad \text{Equation 1.}$$

Where  $a$  is the absolute calibration factor,  $b$  the effective bandwidth and  $DN$  the digital number. The data were converted subsequently to Top Of Atmosphere (TOA) reflectance (%) using:

$$r_{pixel,band} = \frac{L_{pixel,band} * (d_{ES})^2 * \rho}{E_{sun/_{band}} * \cos(q_s)} \quad \text{Equation 2.}$$

## D5.2 VHR land cover maps

where  $L_{\lambda_{pixel,band}}$  represents the TOA band-integrated radiance image pixels,  $E_{sun\lambda_{band}}$  is the band-averaged solar spectral irradiance (see Table C1.3),  $\theta_s$  is the solar zenith angle and  $d_{ES}$  is the Earth-Sun distance. The solar zenith angle was calculated from knowledge of the sun elevation angle ( $sun_{EI}$ ) where:

$$q_s = 90.0 - sun_{EI} \quad \text{Equation 3.}$$

Table C1.2 Calibration coefficients used for the Worldview images acquired over the Italian, Welsh and Dutch sites.

Country	Image	Calibration coefficients	
		a (Absolute calibration factor)	b (Effective band width)
Netherlands	Pan		0.2846
Wales	Coastal	0.009296	0.0473
Italy	Blue	0.017836	0.0543
	Green	0.013642	0.0630
	Yellow	0.005830	0.0374
	Red	0.011036	0.0574
	Red edge	0.005188	0.0393
	NIR-1	0.012244	0.0989
	NIR-2	0.009042	0.0996

Table C1.3 Coefficients used in the determination of TOA reflectance for Worldview images acquired over the Italian, Welsh and Dutch sites.

Image	Band	$E_{sun\lambda_{band}}$
Worldview II	Pan	1580.8140
	Coastal	1758.2229
	Blue	1974.2416
	Green	1856.4104
	Yellow	1738.4791
	Red	1559.4555
	Red edge	1342.0695
	NIR 1	1069.7302
NIR2	861.2866	

The Quickbird imagery acquired over the Italian site of Le Cesine was calibrated with a similar method and using a background calibration module developed by BACRES (P15).

### **C1.2 Pre-processing of airborne hyperspectral and LiDAR datasets**

Light Detection and Ranging (LiDAR) and hyperspectral EAGLEHAWK data were available for both Cors Fochno (Wales) and the Netherlands.

The data for Cors Fochno were acquired in July, 2009, and the area covered included most of the active bog, the surrounding landscape and some of the saltmarsh and estuarine habitats. The LiDAR data were pre-processed using standard LiDAR processing procedures developed by NERC (<http://arsf-dan.nerc.ac.uk/trac/wiki/Processing/LiDARqccprocedure>) and corrections for relative elevation and horizontal planar shifts between flightlines was undertaken. All data were registered to the Ordnance Survey British National Grid. The LiDAR data were converted to a DTM, Digital Surface Model (DSM) and Canopy Height Model (CHM) using SPDLib (Bunting et al., 2011). Comparison with 2006 Vexcel colour infrared aerial photography and vector overlays representing Land Parcel Information System (LPIS) boundaries as well as the OS Mastermap layers representing infrastructure and urban areas indicated a very high degree of geometric accuracy.

Although EAGLE and HAWK data were acquired at the same time, atmospheric water and dust on the sensor led to poor quality data in the HAWK shortwave infrared wavebands and hence these data were unable to be used. The EAGLE data were generally of good quality and were provided as radiometrically calibrated (Level 1b) Hierarchical Data Format (HDF). Orthorectification was undertaken using the Natural Environment Research Council (NERC) Airborne Remote Sensing Facility (ARSF) azgcorr software (Azimuth Systems, 2005). For this, the DTM generated from the airborne LiDAR (1 m spatial resolution) acquired for the main active bog was integrated with the Nextmap Britain DTM (5 m spatial resolution) of the lower Dyfi catchment to generate a nominal 1 m spatial resolution DTM. The accuracy of the geometric registration of the EAGLE data was less than 5 m, and further checks were made by overlaying the LPIS as well as the OS Mastermap urban/infrastructure layers

During the overflights, black and white tarpaulins were laid out at locations within the active bog and spectroradiometer measurements were taken using an ASD Fieldspectroradiometer (FieldSpec Pro). Atmospheric correction was then undertaken using the empirical line technique (Karpouzli and Malthus, 2003) but also using ENVI FLAASH. Reflectance spectra were compared using the two techniques, with that obtained using FLAASH considered to give a more reliable retrieval. Smoothing of the FLAASH corrected reflectance data was undertaken subsequently using the technique of Bunting (2011). An example of the EAGLE data for Cors Fochno is given in Figure C1.1.

For the Netherlands, complete LiDAR coverage was obtained in 2003 for the first time, leading to the construction of a precise national elevation model (AHN-1) with a precision of 15 centimeters and 1 measurement per square meter. The recently obtained second version of the national elevation model (AHN-2) has a precision of approximately 5 centimeters with 10-15 measurements per m<sup>2</sup>. An update is being planned every 5 years, mainly by subscription by the 26 Dutch waterboards, who require this information urgently for their water management. The Ministry of Waterworks pays approximately 50 % of all costs (waterboards the other half). An example of the LiDAR data is provided in Figure C1.2.



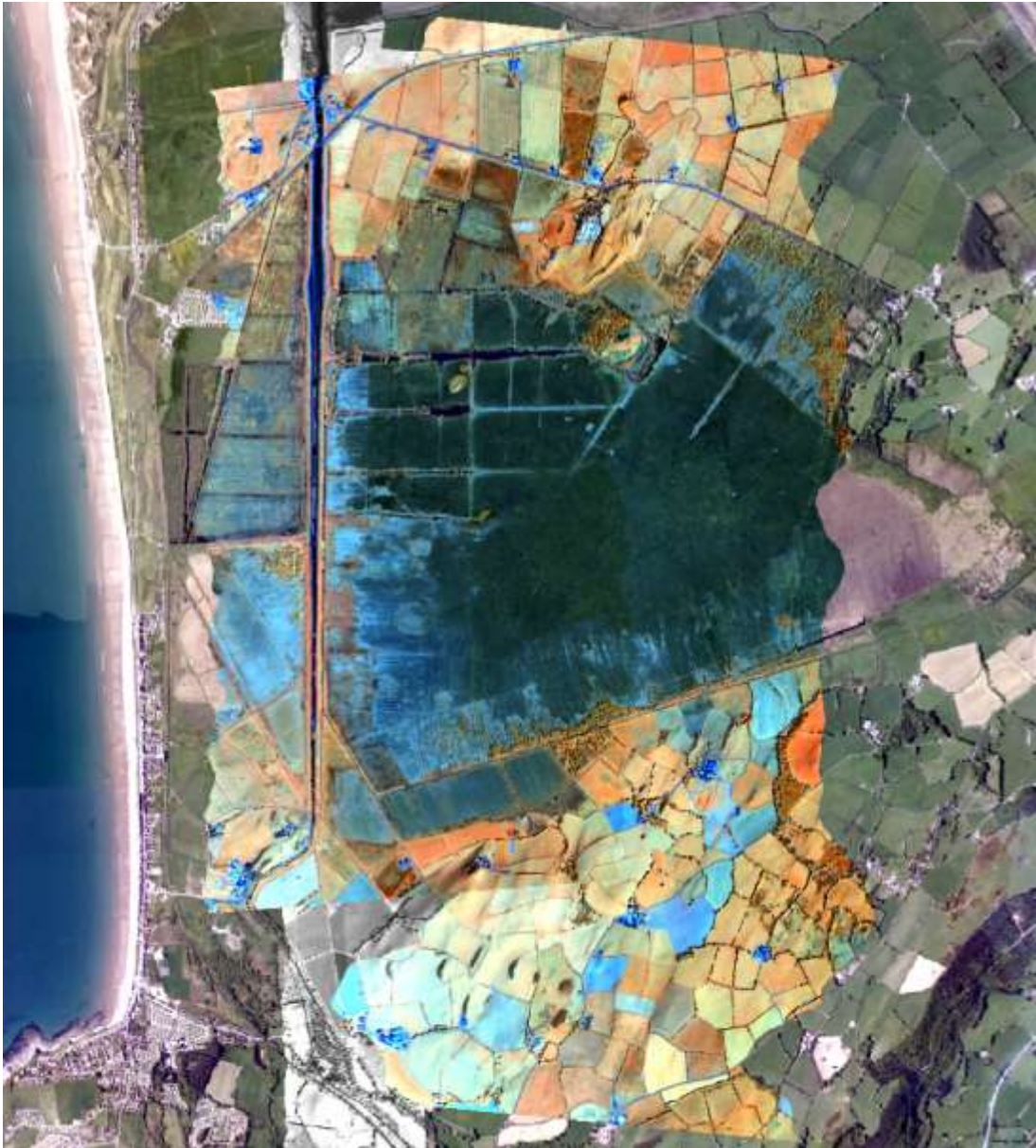

Figure C1.1. EAGLE hyperspectral image, Cors Fochno.

“Fugro Aerial Mapping BV” is one of the companies that collect LiDAR data in the framework of the AHN-2 project. FUGRO uses the FLI-MAP 400 system. This system is carried on board of a helicopter, integrated with high-resolution photo and video camera and a precise GPS system. Additional important characteristics are the options for a 150.000 Hz to 250.000 Hz scan using Multiple Pulse in Air (MPiA) technology, and direct in line-scan attachment of RGB colours to the laser measurements. The absolute accuracy for a single point can be guaranteed below 3 cm. An additional advantage is that data are delivered classified into ground points & non-ground points. Near coincident hyperspectral CHRIS PROBA and airborne AHS-160 data were also acquired in November, 2007.

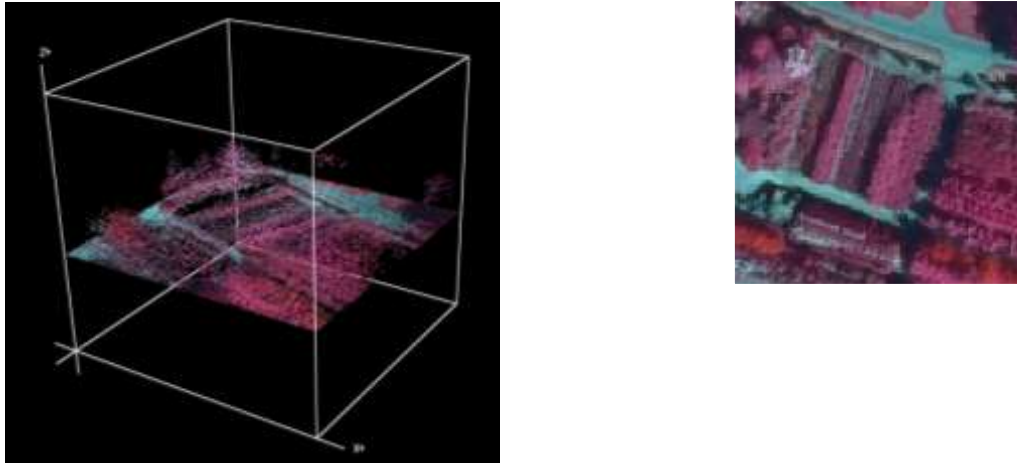

Figure C1.2 Snapshot with the Fusion software for a 3D view which shows the LiDAR points draped over by an aerial photograph.

Whilst illustrated in this deliverable, the inclusion of the LiDAR and hyperspectral data in the classification of LCCS categories and GHCs for Cors Fochno and the Dutch sites will be fully reported in D5\_4.

### C1.3 Overview of image datasets

#### C1.3.1 Italian sites

The Worldview and Quickbird images of Le Cesine are in Figure C1.3a and b respectively, with the two acquired during two contrasting periods (autumn and summer). Le Cesine is a complex site consisting of coastal lagoons, saltmarshes and sand dune complexes together with a diversity of forest types. The cultivated area consists primarily of olive groves. In both images, the vegetation is highly productive and differences between seasons were associated largely with the level of the water in the lagoon and also the productivity of the wetland habitats.

#### C1.3.2 Welsh sites

The Worldview images acquired over Cors Fochno and Cors Caron are shown in Figure C1.4a and b respectively. The dual season (July and November) images of Cors Fochno show the diversity of land covers occurring and highlight particularly well the area of the active raised bog but also the saltmarsh and sand dune complexes. In the July image, much of the vegetation is highly productive (particularly within the enclosed fields) with the exception of the active bog, which contains a greater amount of shrubby (heath) vegetation interspersed with grasslands of low productivity (e.g., dominated by *Eriophorum* species). The November image is more affected by terrain shadow with the exception of the low lying area of the active bog and estuarine complex and surrounding areas. Topographic shadowing is evident in the sand dunes. Differences in the spectral response of the vegetation between the two seasons are evident and are anticipated to lead to better discrimination and classification of LCCS categories.

The April image of Cors Caron conveys the location of the main three active bog domes at the site but also the management practices being followed, including the

## D5.2 VHR land cover maps

installation of artificial bunds to maintain water levels. The image was acquired just prior to the spring flush and hence many areas of vegetation (e.g., the margins of the bog domes which are dominated by purple moor grass or *Molinia caerulea*) were still in a senescent state with a high proportion of non-photosynthetic vegetation. Whilst dual season imagery is preferred, many of the main land cover categories can be visually discerned within the April image.

### **C1.3.3 Dutch sites**

For the Dutch sites of Ginkelse and Eder heide and also Wekeromse Zand, Worldview II data were acquired in June, 2011 (Figure C1.5). The imagery shows the extensive areas of agricultural land and also semi-natural forests as well as the sand dune systems associated with Wekeromse Zand.

D5.2 VHR land cover maps

a)



b)



Figure C1.3. a) WorldView II and b) Quickbird image of Le Cesine Italy acquired in October and June respectively with bands 4 (near infrared), 3 (red) and 1 (blue) displayed in RGB.

D5.2 VHR land cover maps

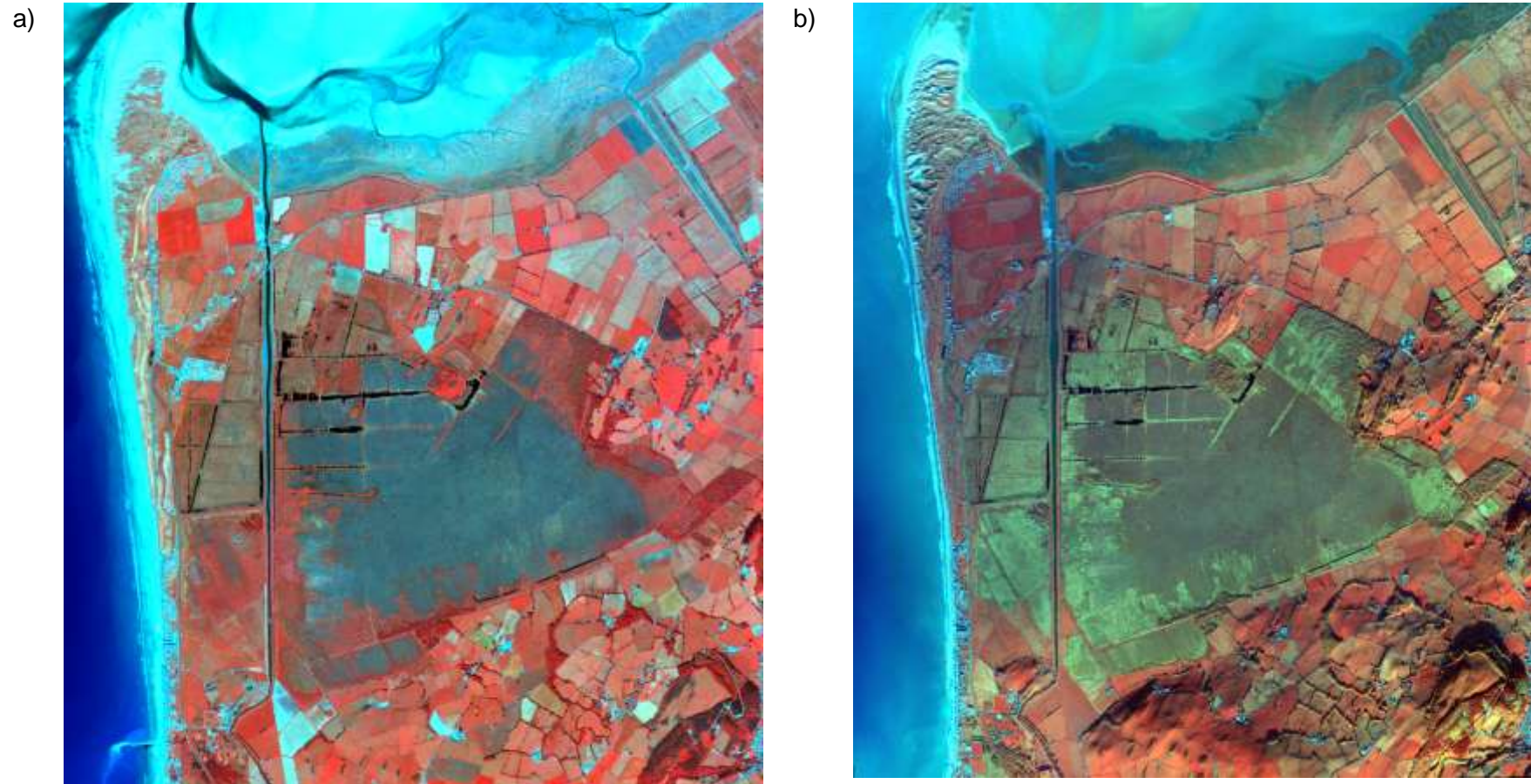

Figure C1.4. WorldView II images of Cors Fochno acquired a) July, 2011 and b) November, 2011 with bands 7 (near infrared), 6 (red edge) and 2 (blue) displayed in RGB.

a)



b)



Figure C1.5. WorldView II image of a) Cors Caron, Wales and b) Wekeromse Zand, Netherlands with bands 7 (near infrared), 5 (red) and 2 (blue) displayed in RGB.

## **D1. Collection of field data for calibration/validation**

### **D1.1 Italian sites**

For the Italian sites, field data were collected during the summer of 2011 with this reported in D6.3. Field data were collected for the IT4 (Le Cesine) in April and September and, for the IT2 (Zone umide della Capitanata-Paludi presso il Golfo di Manfredonia) in May and September.

For the field data collection to support map validation, focus was primarily on IT4 (Le Cesine), because of the greater availability of data and thematic maps produced in the INTERREG III-A Greece-Italy Project "Info-Nat". The available maps include: Land Cover (according to CORINE LC classification) map (scale, 1:5000); Habitat types (according to the Annex I of 92/43/EEC Directive) map (scale, 1:5000); Vegetation map (scale, 1:5000). These thematic maps were generated during the period 2007-2008. The Natura 2000 site of Le Cesine includes a complex of coastal lagoons where an intricate coenological pattern occurs, nested in a matrix of agricultural areas and strongly influenced by human activities. For this reason, focus was on collecting field data from within the Natura 2000 sites and immediate surrounds where agricultural practices were intensive. Based on the existing information and new data acquired, a land cover map according to the LCCS was produced.

#### **Initial stratification**

The area was first divided into 1 km<sup>2</sup> cells. A random sample of three 1 km cells from each broad LC class was taken. No 1 km square contained only one LC class and hence the stratification was based on 100 m<sup>2</sup> cells. Samples were located within the Natura 2000 area, which included the coastal lagoons, saltmarshes, sand dune complexes and all the main natural, semi-natural and anthropic types.

#### **Field-based sampling**

Within each 1 km<sup>2</sup> and 100 m<sup>2</sup> cell, points were randomly selected for the validation of the LCCS map. For each, the geographic coordinates were recorded using a differential Global Positioning System (GPS). Each point was photographed to maintain a visual record of the vegetation occurring.

### **D1.2 Welsh sites**

Field data were collected for the Welsh sites (Cors Fochno but also Cors Caron) in April 2011 and also from July through to October, 2011. For the field data collection, sites were selected on the basis of that reported in D6.2 and focused primarily on Cors Fochno although data were also collected from Cors Caron in conjunction with the Countryside Council for Wales (CCW). The Natura 2000 site of Cors Fochno includes the active bog system and associated habitats that are influenced by events occurring throughout the Dyfi catchment. For this reason, focus was on collecting field data from within the Natura 2000 sites and immediate surrounds but also in the upper catchment. At Cors Caron, attention focused on collecting data from within the Natura 2000 site initially with subsequent field survey planned for the surrounds and the wider Teifi catchment.

#### **D1.2.1 Cors Fochno**

**Initial stratification:** For the Dyfi catchment, the best available mapping has been undertaken as part of the Phase 1 Habitat Survey. The Dyfi catchment was first divided into 1 km<sup>2</sup> cells (Figure D1.1) and from these, the proportion of the 10

## D5.2 VHR land cover maps

major habitat categories reported in the Phase 1 Survey was determined. A random sample of three 1 km cells from each broad habitat category was taken, with GHC field surveys undertaken within up to two 1 km squares within each category. In total, 14 1 km squares were located both within the area of the Natura 2000 site but also outside and across the catchment as activities occurring within this area were considered to have significant future impacts on the state of the protected areas. No 1 km square contained only one habitat category and hence the stratification was based on cells where the habitat represented > 66.6 % of the area. Six of the samples were located within the Natura 2000 area, which included the active bog, saltmarsh and sand dune/estuarine complexes, whilst the remainder was taken outside.

### Sampling the landscape (for GHCs).

Within each 1 km cell selected, a preliminary map of 'objects' was generated using eCognition software and a combination of colour infrared aerial photography and LiDAR data, with the latter processed within SPDLib (Bunting *et al.*, 2011) was used to provide an initial classification. Where appropriate, objects were classified into broad categories (e.g., open water) and those adjoining were merged to form larger objects. An example of the 1 km<sup>2</sup> and a subset of the associated classification is illustrated in Figure D1.2 (repeated from D4\_3). The classification was then removed such that only the linework remained.

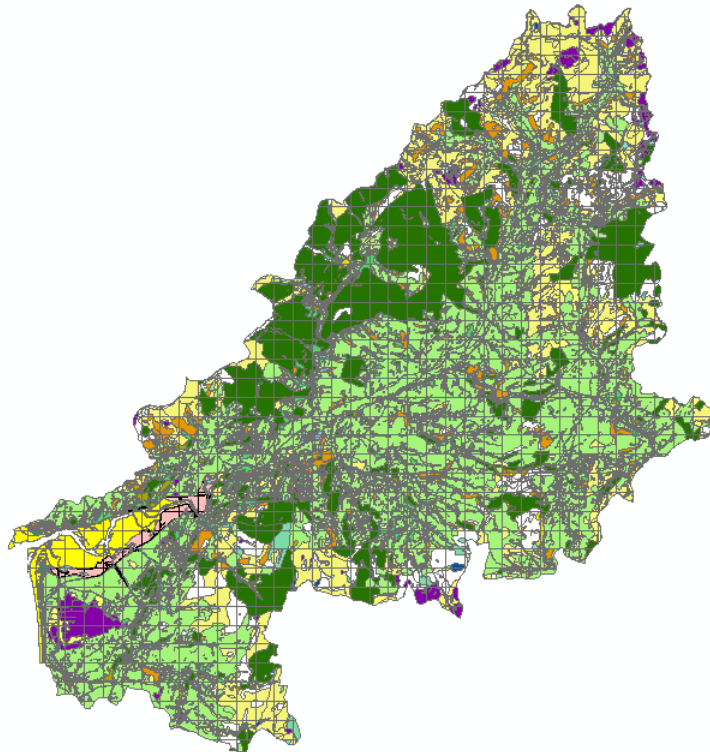

Figure D1.1) LCCS classification derived from the existing Phase 1 Habitat Survey.



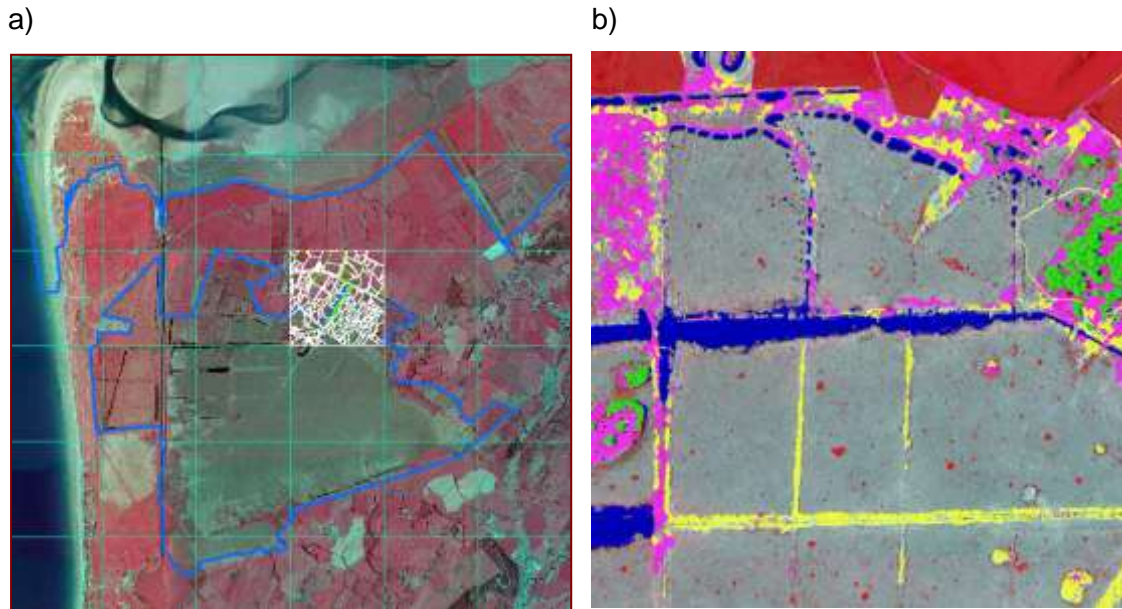
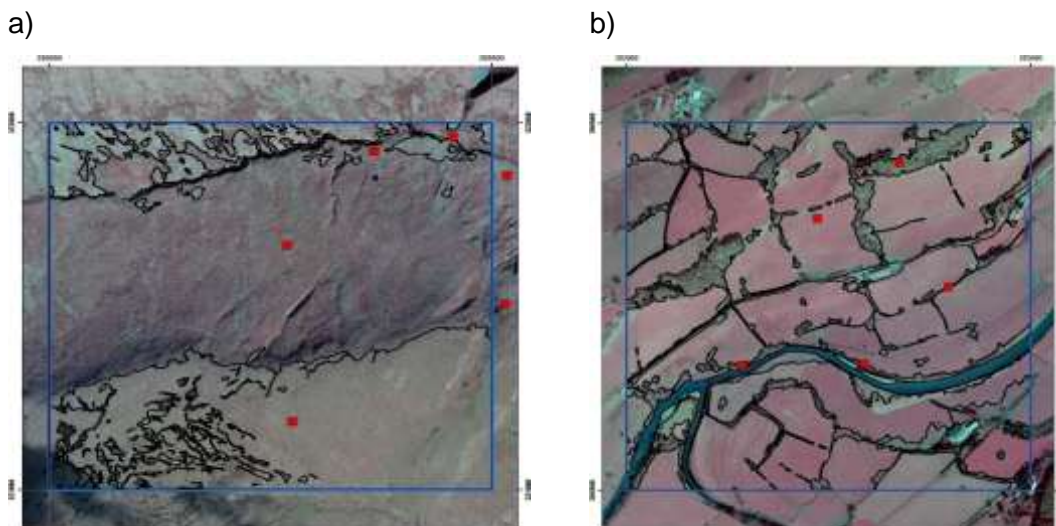

Figure D1.2. a) Selected 1 km x 1 km with segments generated using eCognition overlain. b) a subset showing detailed view of segments classified into open water (blue), woodland and scrub (green), medium tall grasslands dominated by *Molinea/Phragmites* (yellow) and *Juncus* species (magenta) and clusters of shrubs (e.g., *Calluna*) (red). The active bog surface is shown in grey. Improved fields are located at the top of the image (red). The classification was undertaken within eCognition. Areal, linear and point features can be identified.

### Field-based mapping

In the field, each of the 14 1 km<sup>2</sup> was visited and a preliminary map of GHCs generated through field observation and using the linework generated from the object-based classification with eCognition as reference (Figure D1.3). A 100 m grid was then overlain onto the map and the points of intersection of the grid with each GHC category was noted. One point from each category was then randomly selected and the nearest polygon centroid representing the GHC was identified for subsequent field-based sampling.



D5.2 VHR land cover maps

c)

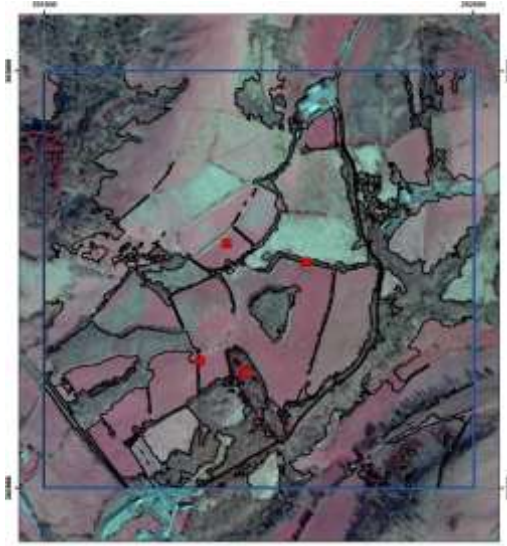

d)

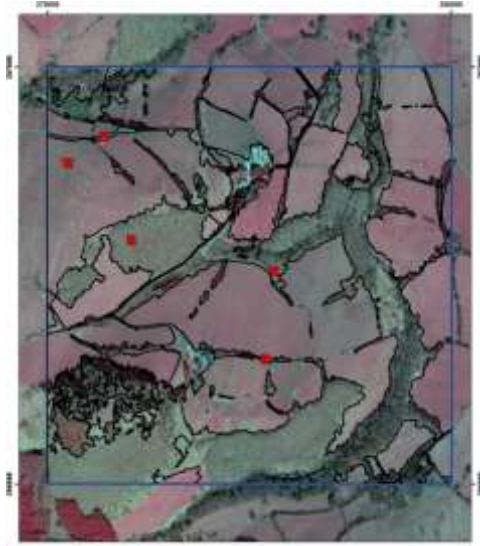

e)

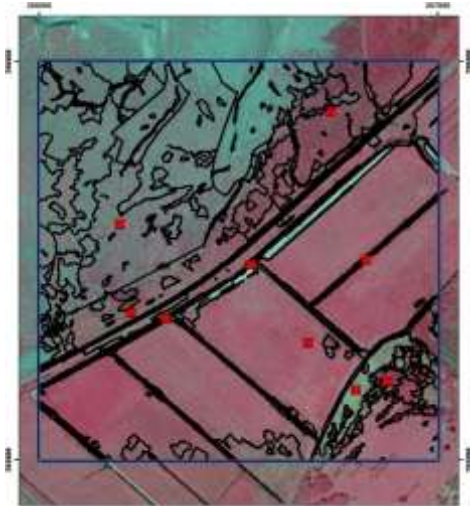

f)

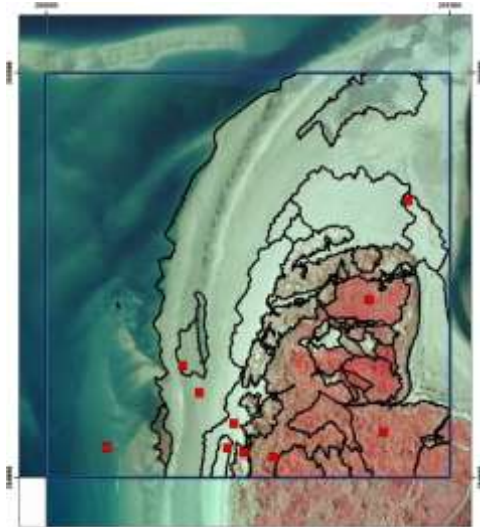

## D5.2 VHR land cover maps

g)

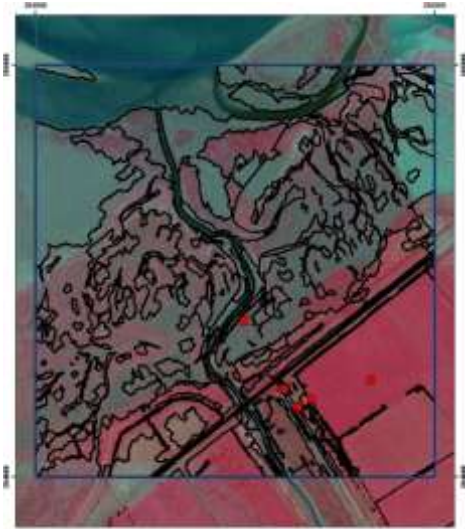

h)



i)

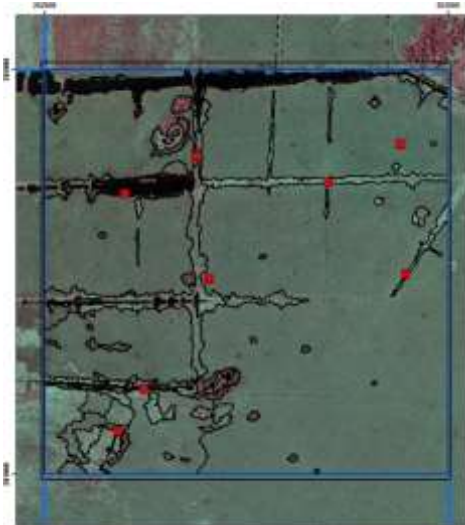

j)

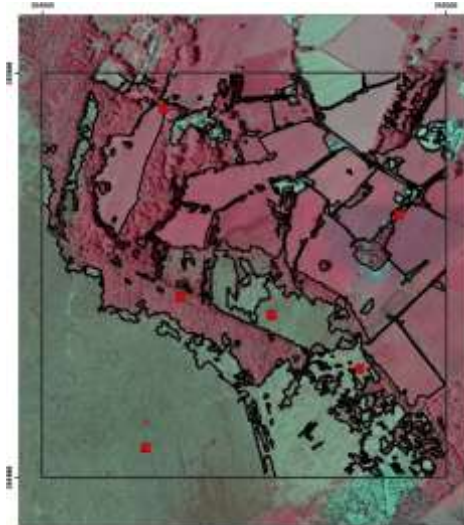

k)

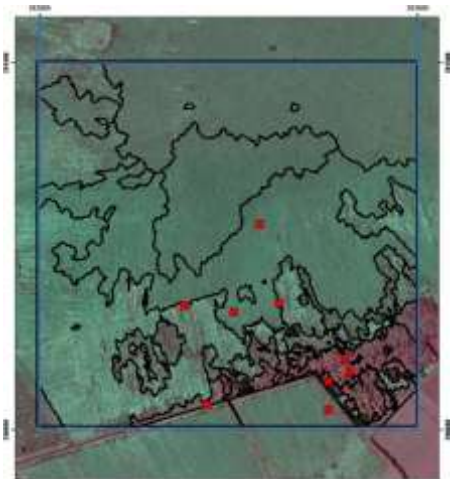

l)

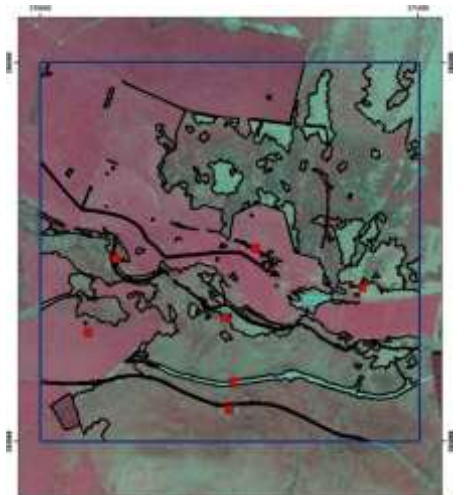

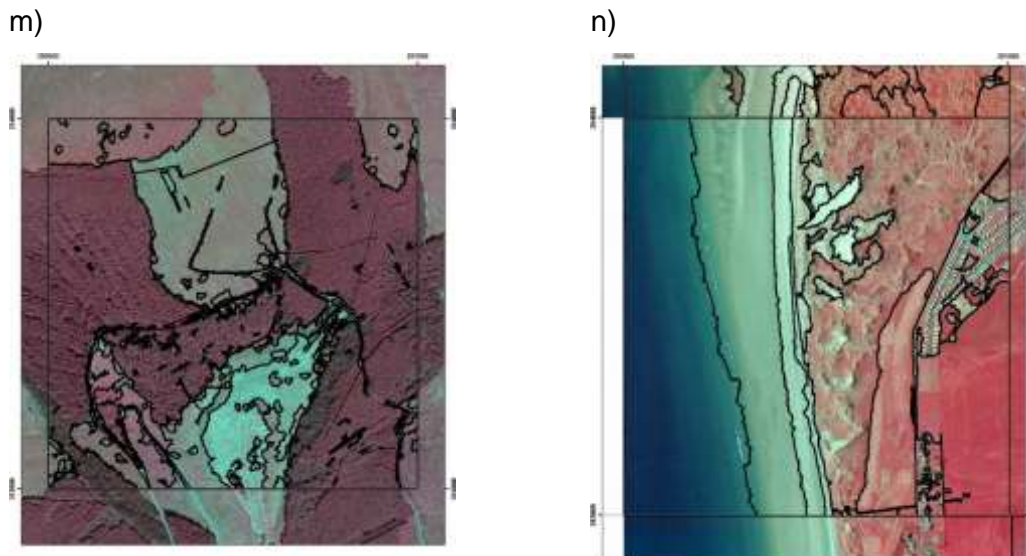

Figure D1.3. Overview of the linework associated with each of the 1 km<sup>2</sup> selected randomly within the Dyfi catchment with a to l representing landcovers including saltmarsh, active bog and sand dunes.

### Field-based sampling

Within each 1 km<sup>2</sup> and for each broad GHC, an areal, point or linear plot was established. For the nested 10 x 10 m areal plots, quadrats of 4m<sup>2</sup>, 25m<sup>2</sup> plot, 50 m<sup>2</sup> and 100 m<sup>2</sup> were laid out, although where the vegetation was considered especially vulnerable (e.g., on the active bog domes), only 2 x 2 m plots were recorded. Along linear features such as rivers, ditches or hedges, a linear plot of 1 x 10 m was located. For each, the geographic coordinates were recorded using a differential Global Positioning System (GPS) and the orientation of the linear plots was also recorded. Each point, linear and areal survey quadrat was photographed to maintain a visual record of the vegetation occurring. Within all plots, measurements of vegetation were undertaken using the GHC field sampling protocols (Bunce et al., 2011). The locations of sample plots within the GHC maps are given in Figure D1.4

### Additional field sampling

In addition to the plots laid out during the GHC sampling, a number of additional 2 x 2 m point and 10 x 1 linear plots were also established with these located across a range of GHCs and in areas that were relatively homogeneous in terms of their structure and species composition. The surveys were undertaken in conjunction with CCW (based on the fast-track approach) and largely to inform the classification of the imagery but also be used for subsequent validation. Whilst some of the sampling was not stratified, points were selected from the range of GHCs occurring with study site, with a number of points located in primary active bog, degenerated (secondary) bog and regenerating bog (rewetted agricultural land that had previously been active bog). Focus was also on areas of known change.

## D5.2 VHR land cover maps

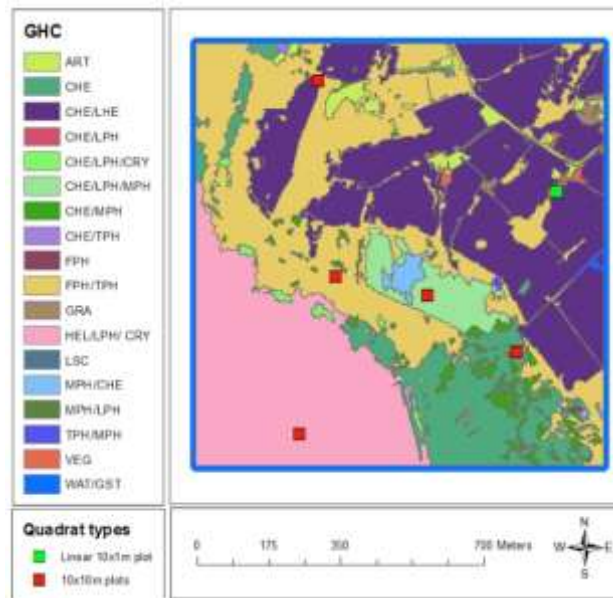

Figure D1.5. A map of GHCs generated from field survey with the location of linear and areal plots indicated.

### Collation of existing datasets

In D6.2, the case was made for obtaining a large number of samples to meet the requirements of error tolerance and accuracy. Obtaining such information given the time frame and resources of the project was considered unrealistic and therefore data were collated from a range of sources and particularly from previous surveys undertaken by organisations including the Countryside Council for Wales (CCW) and Manchester University. At the time of writing, these datasets were being converted from their native classification (e.g., National Vegetation Survey (NVC) categories) to GHCs where possible.

### D1.2.2 Cors Caron

For Cors Caron, the survey was undertaken with CCW botanists from April, 2011, through to October, 2011. During each visit, a fast track approach was adopted such that samples were taken within the major vegetation types occurring. Sites for sampling were identified through reference to aerial photography but also local knowledge of the site and a combination of 2 x 2 point plots and 10 x 1 linear plots was used. The data were used primarily to understand and train the classification of the imagery with a subsequent field visit planned to support validation.

### D1.3 Dutch sites

Recent field data were collected for the Dutch case study area during the summer of 2011, including the GHC mapping of 12 selected samples and the recording of vegetation plots according to the protocols of the GHC handbook (Bunce et al., 2011). For GHC sampling, a stratified random approach was undertaken, with the GHC maps intended for validating the maps generated from VHR data. In parallel, and from the beginning of June until the end of growing season, point samples of homogeneous vegetation patches were collected in a fast-track manner (non-stratified), primarily to train the classification of VHR data and provide validation data.

## D5.2 VHR land cover maps

In the past, fieldwork had been collected as part of the HABISTAT project, coincident with the airborne campaign in October 2007 and through to the spring of 2008. Reference plots of 100 m<sup>2</sup> were measured on the day of the flight campaign in order to support and validate the atmospheric correction of the acquired hyperspectral imagery. Reference plots consisted of homogeneous areas with bright or dark characteristics (e.g. sand, water, asphalt) that were measured using a Fieldspec PRO Fr spectroradiometer. Twenty transect plots of 10 m each were measured (at distances of 2.5 m within the transect) at the same day to characterize the reflectance properties of a selected set of vegetation types. In a later instance, these plots were characterized in terms of their vegetation composition. Field samples to train and validate the spectral mixture analysis were collected in the period after the image acquisition between October 2007 and April 2008. Sampling locations were selected by laying out a regular grid over the study area with a sampling distance of 250 m. Geographic coordinates for every location were collected with a Garmin handheld global position system unit. For every location, a description of the habitat types was made according to the methodology established in the BioHab project (Bunce et al., 2008). Additional field recordings were made when other vegetation types occurred near the systematic grid point. For each sample, a point location with a radius of 3 m, the composition of plant life forms was recorded by their coverage in percentage (using a vertical projection) together with the dominant species of every life form. Based on this information, a classification into habitat types was made. A total of 104 field samples were recorded in the study area and for every plot, overhead and oblique field photos were taken. A geodatabase was constructed with vegetation and structure maps for different years obtained from Dienst Vastgoed Defensie (DVD). The vegetation maps contained the relevant phytosociological plant communities, and was available for 1997 with an update in 2009. The structure maps indicated the degree of grass encroachment, and was available for 2003 with an update in 2009. The maps were largely based on field surveys, supported by aerial photo interpretations. No information was available on the accuracies of these maps. An overview of the samples taken in the past is given in Figure D1.6.

## D5.2 VHR land cover maps

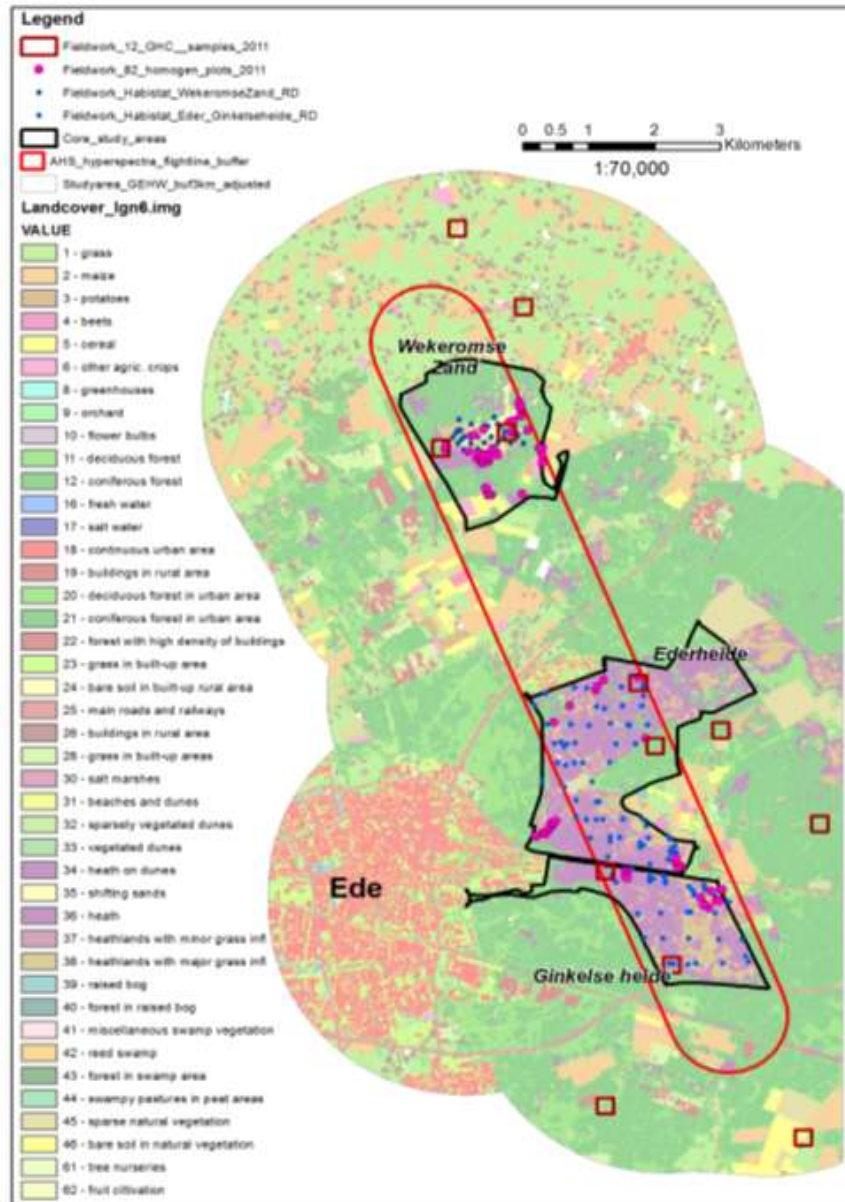

Figure D1.6. Dutch study area with the locations of recent fieldwork, but also indicating locations of field work undertaken in 2007 and 2008 as part of the HABISTAT project.

### Initial stratification

In 2011, a fishnet of 250 m was generated over the Dutch study area within ArcGIS, which was used as the initial sample grid and spatially matched the grids of the Dutch National Land Cover Database. The GHC sample sites proposed were smaller than the 1 km squares intended originally, largely because of time and resource constraints, but it was assumed that a greater number of sample sites would be better than a limited amount of 1 km samples. A stratified random sampling approach was adopted which used the major land cover categories from the 25 m spatial resolution National Land Cover Database (classified within an overall accuracy of 85 %). Land cover statistics were calculated separately for major categories inside and outside the protected core sites. The number of samples (12) was weighted by the area of major land cover class, both inside (6) and outside (6) of the protected sites (although within a 3 km buffer). Within the protected area, samples were placed in

## D5.2 VHR land cover maps

the semi-natural heath (3), drifting sand (1) and forest areas (2) and, within the 3 km buffer zone outside of the protected sites, samples were placed in the forest (3) and the agricultural areas (3) (Tables D1.1 and D1.2). All samples were 6.25 ha in area.

Table D1.1. Land cover statistics for major classes in protected sites

<b>Major Land Cover Class</b>	<b>Area_ha</b>	<b>Area (%)</b>	<b>No. Samples</b>
Urban	6.9	0.5	
Agriculture	34.3	2.3	
Forest	483.9	32.6	2.0
Semi-natural area	959.6	64.6	3.9
Water	0.3	0.0	
<b>Totals</b>	<b>1484.9</b>	<b>100.0</b>	<b>6</b>

Table D1.2. Land cover statistics for major classes within the bufferzone

<b>Major land Cover Class</b>	<b>Area_ha</b>	<b>Area (%)</b>	<b>No. Samples</b>
<b>Urban</b>	<b>2259.6</b>	<b>21.1</b>	
<b>Agriculture</b>	<b>3514.1</b>	<b>32.8</b>	<b>3</b>
<b>Forest</b>	<b>4395.6</b>	<b>41.0</b>	<b>3</b>
<b>Water</b>	<b>26.7</b>	<b>0.2</b>	
<b>Nature</b>	<b>515.4</b>	<b>4.8</b>	
	<b>10711.3</b>	<b>100.0</b>	<b>6</b>

### Field-based sampling

The GHC fieldwork at each of the 12 sample squares was undertaken during the second half of June and the first half of July, 2011. In August, 2011, 51 vegetation plots were sampled within the principle GHC categories encountered, with this undertaken using the protocols of the field handbook (Bunce et al., 2011). Only the six sample squares located within the protected areas were sampled, with a plot placed in the centre of each major GHC observed. As with the previous sites, the species and their abundance were recorded within 10 x 10 m areal plots. Photographs of each plot were also taken. Images of the sampled sites are presented in Figure D1.7.



## D5.2 VHR land cover maps

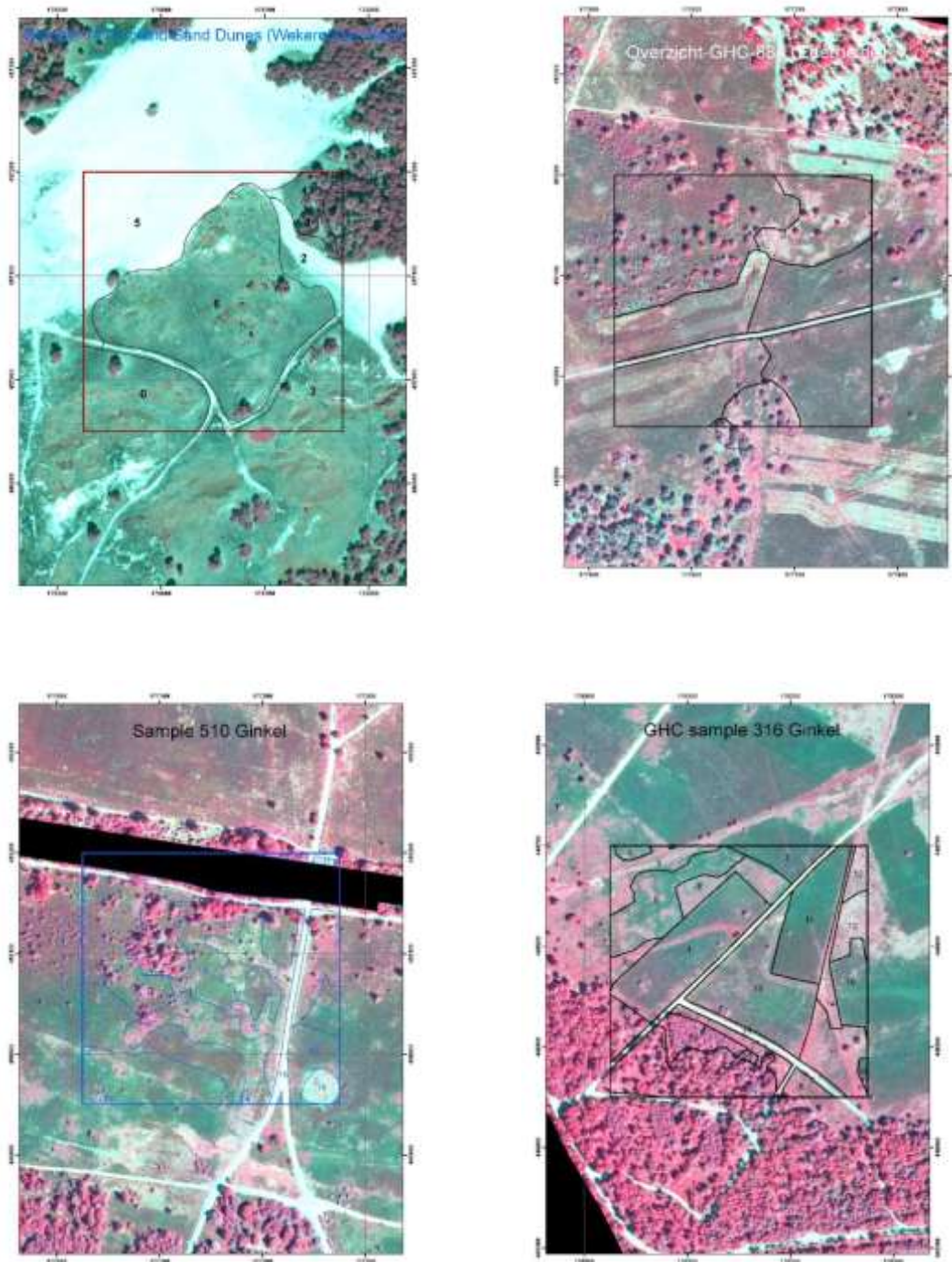

Figure D1.7. a) Inland sand and heathland core samples with basic patches (prior to field data collection)

## D5.2 VHR land cover maps

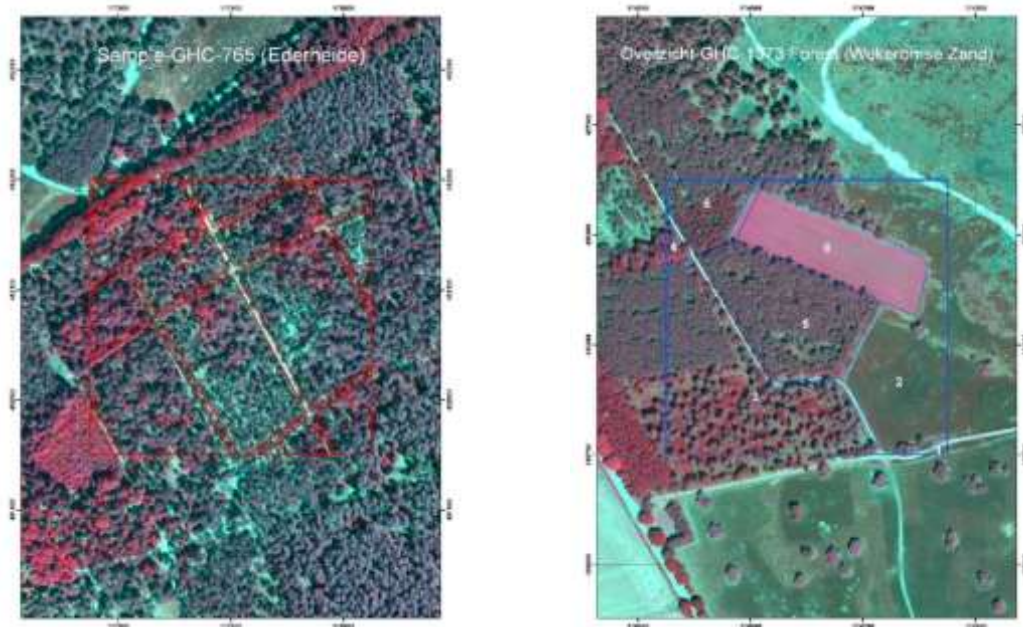

Figure D1.7. b) Forest core samples with basic patches.

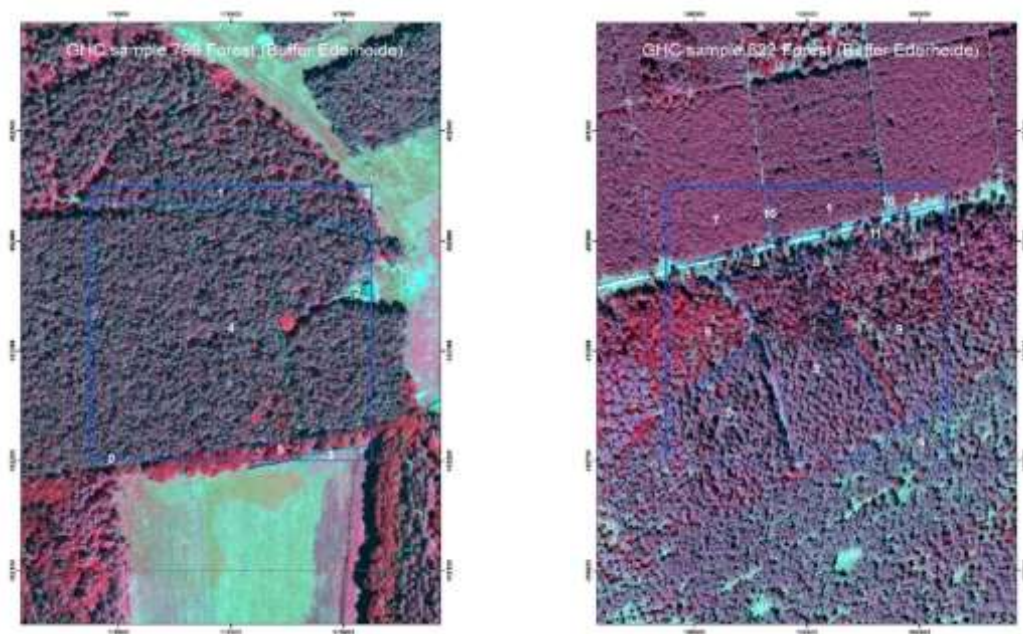

Figure D1.7. c) Forest samples in buffer zone with basic patches.

## D5.2 VHR land cover maps

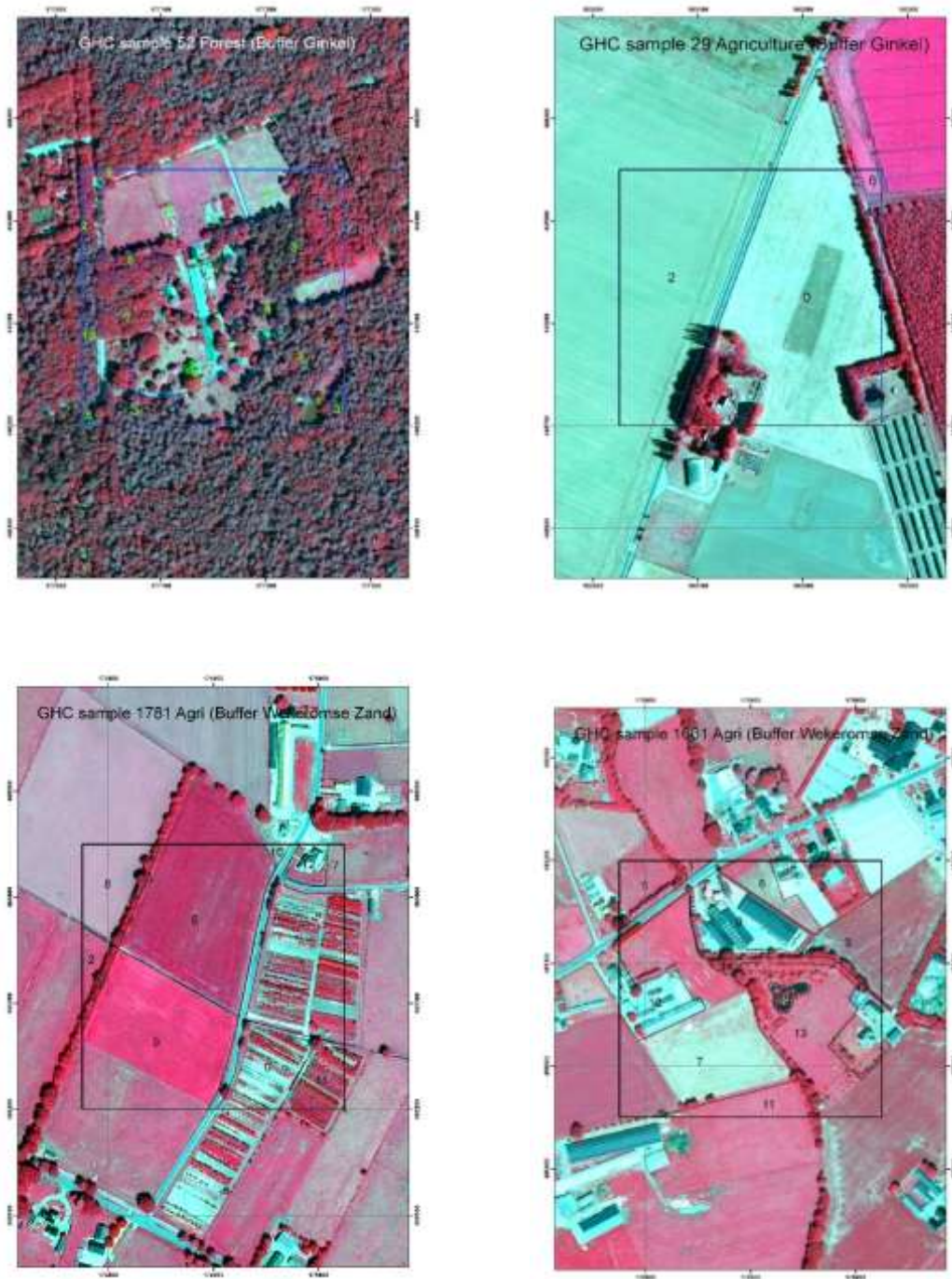

Figure D1.7. d) Selected Forest and agricultural samples in buffer

## D1.4. Summary of available data

### D1.4.1 Italian sites

For the Italian sites, a pre-existing LC/LU map is available produced within a previous INTERREG project. The map will be used to select validation data according to the strategy developed in D4.3.

### D1.4.2 Welsh sites

For both the Dyfi catchment (including Cors Fochno) and Cors Caron, the spatial distribution of sample plots is presented in Figures D1.9 and D1.10. 178 samples were taken at Cors Fochno, with the number of plots associated with each of the different GHCs recorded indicated in Table D1.3. The majority was located within grasslands and the active bog, although 31 different GHCs were encountered. Each of these GHCs could be translated to an equivalent LCCS category.

Table D1.3. GHCs occurring within Cors Fochno and the number of sample plots associated with each.

GHC	No.	GHC	No.	GHC	No.	GHC	No.
HER/HEL HER/CHE	or 2	HER/CRY HER/HEL	or 5	HER/HEL HER/CRY	or 3	TRS/SCH	11
HER/CHE	27	HER/CRY TRS/SCH	or 3	HER/HEL TRS/SCH	or 5	TRS/SCH HER/CRY	or 2
HER/CHE HER/HEL	or 1	SPV/EAR	1	HER/LHE	4	TRS/SCH HER/HEL	or 15
HER/LHE /CHE	1	HER/EHY	6	TRS/LPH	6	TRS/TPH	1
HER/CHE TRS/LPH	or 4	HER/GEO	3	TRS/LPH HER/CHE	or 2	TRS/TPH HER/CRY	or 1
HER/CHE TRS /SCH	or 6			TRS/LPH HER/HEL	or 1	SPV/AQU	3
HER/CRY	12	HER/HEL	48	TRS/MPH	2	WAT HER/HEL	or 1
HER/CHE /CRY	1			TRS/MPH HER/CHE	or 1		

Within Cors Caron, 100 samples were taken with these distributed between 22 GHCs (Table D1.4). The majority was again associated with the grasslands and bog habitats, which are the most widespread within the study area.

D5.2 VHR land cover maps

Table D1.4. GHCs occurring within Cors Fochno and the number of sample plots associated with each.

<b>GHC</b>	<b>No.</b>	<b>GHC</b>	<b>No.</b>	<b>GHC</b>	<b>No.</b>
HER/CHE	30	SPV/EAR	2	TRS/LPH TRS/MPH	or 1
HER/CHE or HER/HEL	2	HER/EHY or SPV/AQU	1	TRS/MPH HER/CRY	or 1
HER/CHE or TRS/MPH	1	HER/HEL	21	TRS/MPH HER/LHE	or 1
HER/CHE or TRS/TPH	1	HER/HEL or HER/CRY	4	TRS/SCH	2
HER/CRY	8	HER/HEL or TRS/SCH	2	TRS/SCH HER/CRY	or 1
HER/CHE /CRY	1	HER/LHE	2	SPV/AQU	2
HER/CRY or HER/HEL	11	TRS/LPH	3		
HER/CRY or TRS/MPH	1	TRS/LPH or HER/CRY	2		

## D5.2 VHR land cover maps

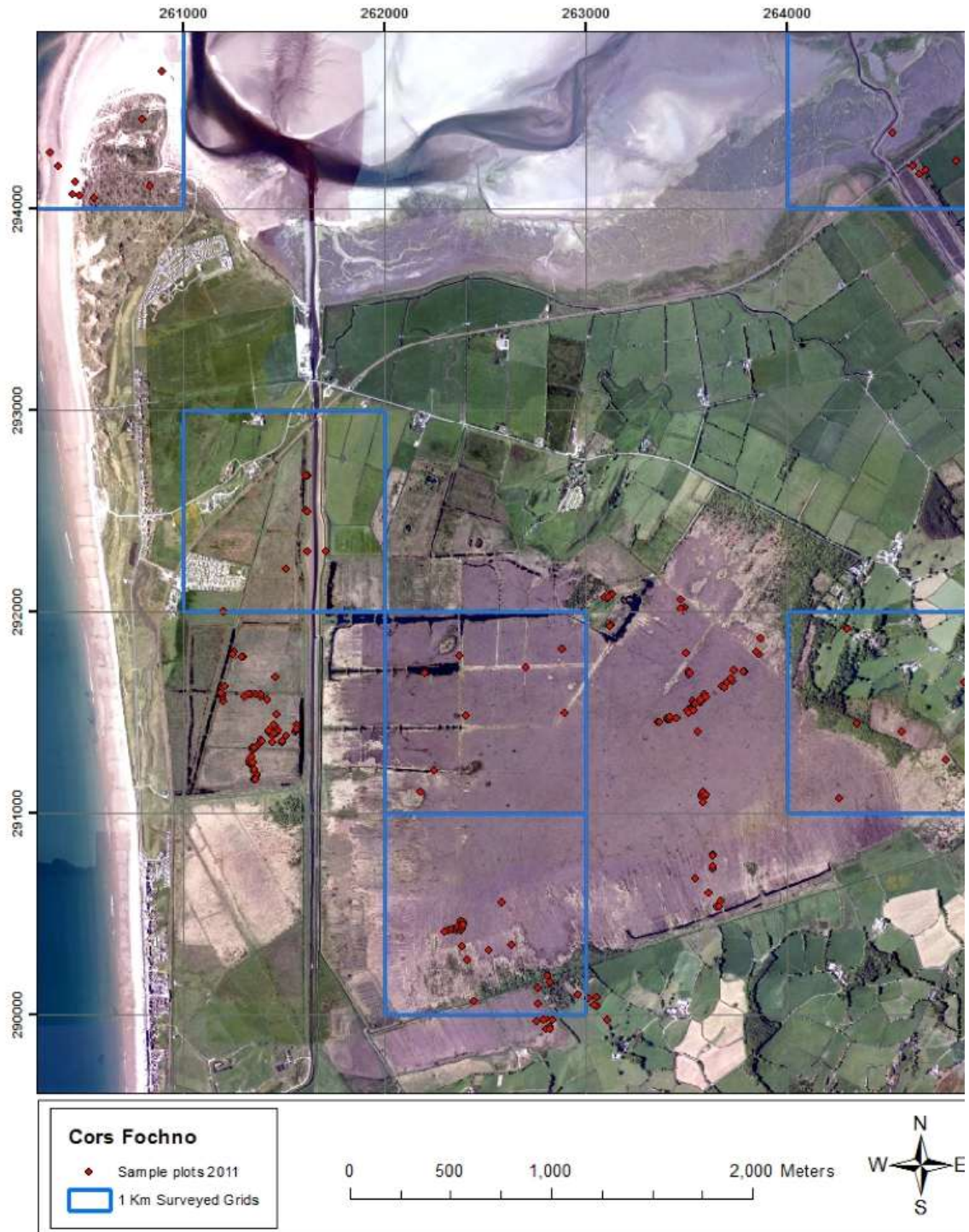

Figure D1.9. Distribution of sample locations within Cors Fochno

## D5.2 VHR land cover maps

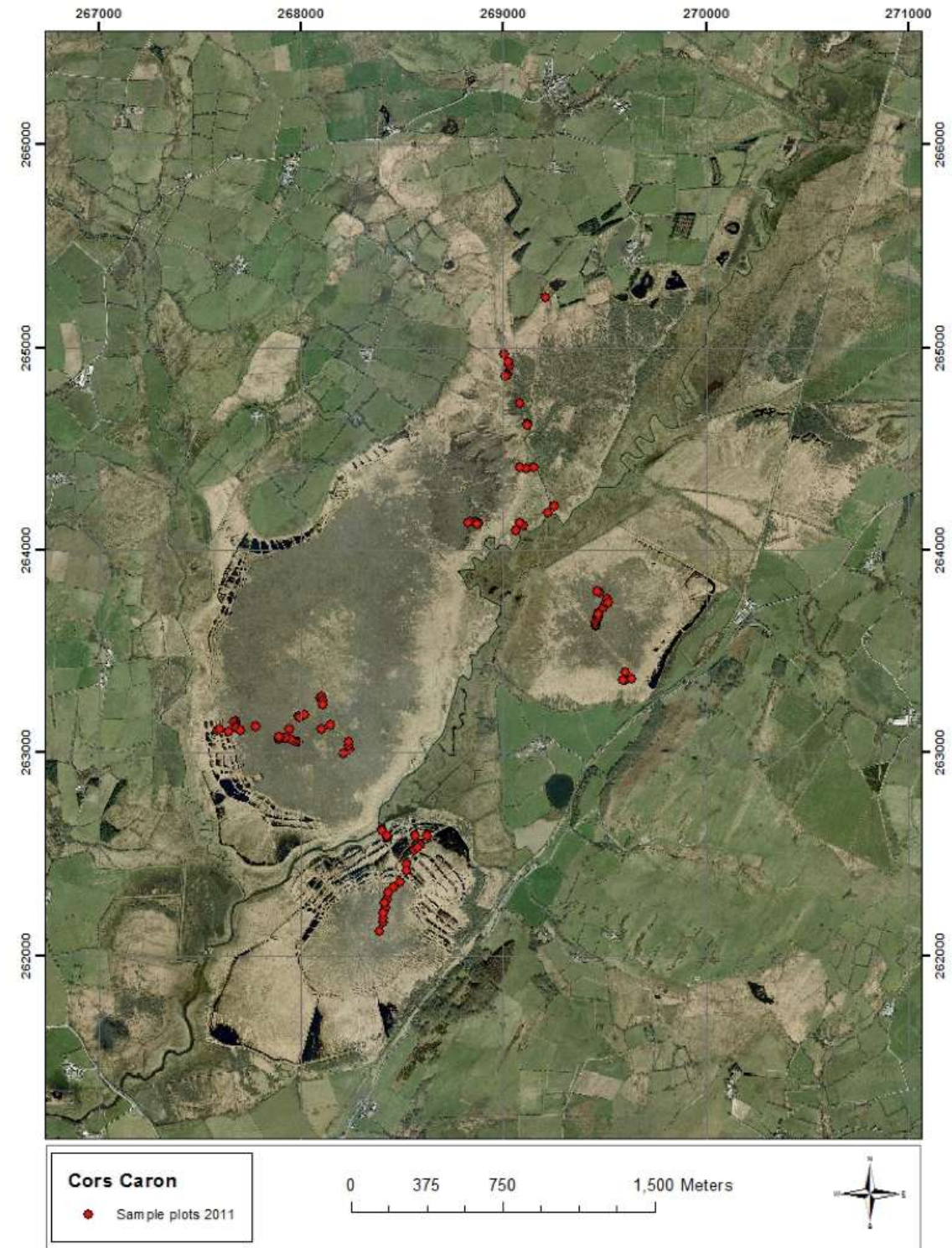

Figure D1.10. Distribution of sample sites within Cors Caron.

### D1.4.3 Dutch sites

For the Dutch sites, maps of sample points are provided in Figure D1.11. The 20 GHCs and lifeforms recorded within the 12 randomly selected samples during the initial field sampling are listed in Table D1.5.

Table D1.5. GHCs and life forms encountered within the 12 stratified random samples

Sample no	GHCs	Life Forms
1	URB/ART	URB/ART
2	URB/GRA	URB/GRA
3	URB/GRA/TRE	URB/NON
4	URB/NON	URB/TRE
5	URB/TRE	URB/VEG
6	URB/VEG	CUL/CRO
7	URB/VEG/TRE	CUL/WOC
8	CUL/CRO	SPV/EAR
9	SPV/SAN	SPV/SAN
10	HER/CHE	HER/CHE
11	HER/CHE/CRY	HER/CRY
12	HER/CRY	HER/LHE
13	HER/LHE	TRS/FPH/CON
14	HER/LHE/CHE	TRS/FPH/DEC
15	TRS/FPH/CON	TRS/LPH/CON
16	TRS/FPH/DEC	TRS/LPH/DEC
17	TRS/FPH/DEC/CON	TRS/LPH/EVR
18	TRS/LPH/EVR	TRS/SCH/EVR
19	TRS/SCH/EVR	TRS/TPH/CON
20	TRS/TPH/DEC	TRS/TPH/DEC



## D5.2 VHR land cover maps

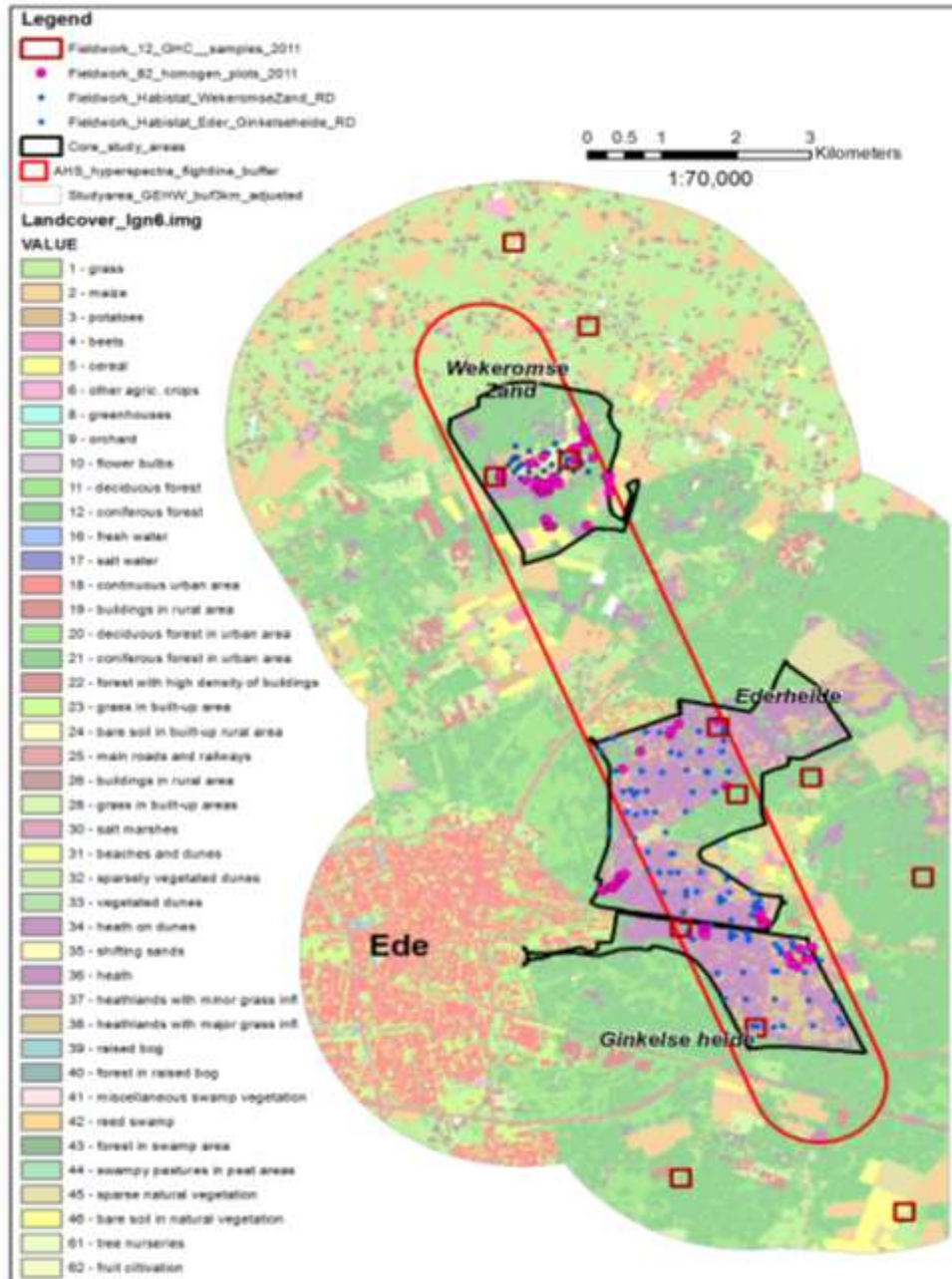

Figure D1.11. Distribution of sample locations within the Italian sites

### D1.5 Critique of field data collection

For each of the sites in Italy, Wales and the Netherlands, extensive ground truth datasets have been collected. In the case of Wales and Netherlands, primary focus has been on the collection of data relating to GHCs (following protocols), which can then be translated to LCCS categories and used for validation of classifications from VHR and hyperspectral imagery. In the case of Italy, primary focus has been on the collection of data relating to LCCS categories, which can then be translated to GHCs.

## D5.2 VHR land cover maps

The data have also been collected to support interpretation of the imagery, the development of the 1<sup>st</sup> and 2<sup>nd</sup> stage classifications from spectral data and derived measures (e.g., texture, fuzzy membership to classes) and inclusion of semantic nets in the classification process.

When collecting the field data, a number of issues were highlighted.

- a) The locations associated with the polygon centroids were not always placed within the GHC associated with the delineated polygons because of variability in vegetation structure and type. On several occasions, the plots were located within vegetation linked to the GHC that was closest to the random sample point.
- b) The centroids of polygons were sometimes located within a difference GHC because of their shapes.
- c) The linear plots were found to well represent the GHCs occurring alongside, for example, water bodies or tracks.
- d) Whilst the 10 x 10 areal plots allowed a more detailed species list to be generated, these were considered to be unnecessarily large when placed in vegetation of low diversity or monocultures (e.g., stands of *Molinia caerulea*).
- e) In tussock grasslands, such as those dominated by *Molinia*, the 10 x 10 quadrat was difficult to establish and led to damage to the vegetation. When sampling the active bog, permission to undertake such a survey would not be given.
- f) The time taken to complete an area plot was considered to be too long and more plots could have been established over the same time period if these were point or linear.
- g) Within some areas that were visited, conditions changed from dry to waterlogged resulting in the recording of a separate GHC.
- h) When randomly sampling sites, their locations may be at opposite ends of a 1 km square, which required considerable time in terms of transiting from one site to another.

For future implementation of GHC survey, the practicalities of accessing areas (e.g., because of adverse conditions or lack of permissions or environmental conditions) need to be taken into consideration. Any requirement to take a large number of samples needs to carefully consider the costs, particularly in terms of time and finances. In many cases, the use of independent sources of information (e.g., aerial photograph interpretation) or existing datasets needs to be considered.

## E1. Generation of LCCS maps from VHR data

### E1.1 Generation of 1st stage maps

For the Italian, Welsh and Dutch sites, the 2<sup>nd</sup> stage of the EODHAM system was developed with this based upon the 1<sup>st</sup> stage EODHAM output maps. These maps were based on a) the SIAM<sup>TM</sup> pre-classification map of spectral categories and b) segments generated and classified within eCognition.

*From SIAM<sup>TM</sup>.*

The SIAM<sup>TM</sup> generates a 1<sup>st</sup> stage preliminary classification map (primal sketch) of the landscape from a single-date single sensor input image calibrated into top of atmosphere reflectance (TOARF) without any ground truth. Each input pixel is mapped onto a discrete and finite set of spectral (color) categories that can be grouped into six mutually exclusive parent spectral categories (also called super-categories and strata): 1) *water or shadow*, 2) *snow or ice*, 3) *clouds*, 4) *vegetation*, 5) *bare soil or built-up*, 6) *outliers*. Each strata is equivalent to a land cover class set. Thus, spectral categories are provided with a symbolic (semantic) meaning [Baraldi 2006, 2010]. The number of output spectral categories is fixed depending on the input sensor with three different semantic granularity. For VHR imagery (i.e. Quickbird, IKONOS) 12, 28 and 52 spectral categories contained within hierarchical levels, with these representing coarse, intermediate and fine semantic granularity respectively. To discriminate each final land cover class, an additional second stage processing level is required with this based on class description and class specific features extraction modules. Whilst suited to single date imagery, the use of spectral categories becomes more complex when multi-date imagery is needed for final class discrimination since rule sets that combine the separate preliminary spectral map from each date need to be developed. In many cases, a spectral category on one date can be represented by several on another (e.g., because of phonological differences) and hence multiple configurations arise.

*By eCognition*

Whilst spectral categories are not used in eCognition, segmentation of the imagery can be achieved based on available algorithms. For the BIO\_SOS project, segmentation using a combination of the chessboard and spectral difference algorithms provided a realistic representation of the landscape at the various test sites, with the inclusion of pre-existing ancillary information (e.g., Cadastral layers) providing more reliable delineation of certain features (e.g., roads under trees and cultivated areas without distinct boundaries). For classification, a number of spectral indices were considered essential, including the Normalised Difference Vegetation Index (NDVI) and water band indices (WBI). Classes defined from these data and indices (which were identical to those defined by SIAM<sup>TM</sup>) included vegetation (but additionally encompassing submerged and non-photosynthetic vegetation) and urban areas (defined using an existing data layer, although with potential for discrimination directly from the imagery).

In this sense, a 1<sup>st</sup> stage segmentation can be obtained using both methods but eCognition does not first associate each segment with a spectral category. In each case and in the 2<sup>nd</sup> stage, the segments have to be combined to classify land covers and similar procedures are adopted for this. Maps generated using both methods are presented in the following sections and the relative merits of each are discussed at the end of the report.

## E1.2 Input layers for Generation of 2<sup>nd</sup> stage maps

The 2<sup>nd</sup> stage maps are intended to represent the LC classes in LCCS taxonomy and can be generated from the 1<sup>st</sup> stage maps/segments (regardless of their derivation) using the following:

- a) Existing thematic data
- b) Key data layers from remote sensing data
- c) A battery of feature extraction modules based on spectral and textural information.
- d) Descriptions of LCCS categories (and their components), with this based on semantic nets that specifically link descriptions in the field and from remote sensing data.
- e) Stratified class-specific fuzzy rule-based classification modules.

The following sections outline each of these in turn and examples are provided. Whilst some have been implemented, significant opportunities for refinement have been identified and will be implemented in future deliverables within WP5.

### E1.2.1 Thematic data

The requirement for ancillary data was highlighted in D5.1 for the Welsh sites, where a number of existing data layers were needed to generate maps of LCCS categories (Table E.1). In all three study areas, these datasets have themselves been generated from VHR data. In particular, cadastral information and the extent of urban infrastructure (buildings, transportation networks) and water bodies is typically obtained through manual delineation within stereo photography, elevation is obtained using, for example, radar interferometry, LiDAR or stereo photography. The challenge for the BIOSOS project is to obtain such information (with the exception of elevation) from the VHR imagery itself using automated feature extraction techniques. However, for the preliminary mapping, existing datasets have been used although the potential for automated extraction has been evaluated for some categories.

Table E1.1 List of ancillary data layers required for the classification of LCCS categories

Acronym	Country	Dataset	Use in the LCCS classification
Cadastral	Italy	CTR <sup>1</sup>	Identifying cultivated and semi-natural/natural areas
	Wales	LPIS <sup>2</sup>	
	Netherlands	Top10-vector <sup>3</sup>	
Infrastructure	Italy	None	Defining the extent of infrastructure
	Wales	OS Mastermap	
	Netherlands	Top10-vector <sup>2</sup>	
Elevation	Italy	none	Allowing inclusion of rules based on elevation and topography
	Wales	Nextmap Britain	
	Netherlands	AHN-LiDAR	
Artificial waterbodies	Italy	none	Identifying permanent artificial structures (e.g., reservoirs)
	Wales	insert	
	Netherlands	Top10-vector <sup>2</sup>	

<sup>1</sup>Regional Technical Chart (CTR); <sup>2</sup>Land Parcel Information System (LPIS); <sup>3</sup>Top10-vector: Dutch topographic maps at scale 1:10.000, available in digital format with many different layers.

### E1.2.2 Key data layers

For the classification of LCCS to Level 3, the decisions are based on identifying and mapping key surface types, with these listed in Table E1.2. In the case of vegetation, classification of non-photosynthetic and submerged vegetation as well as photosynthetic terrestrial vegetation is needed, with these each exhibiting markedly different spectral characteristics. Within cultivated areas, a distinction needs to be made between agricultural crops (including permanent grasslands), tree crops (e.g., fruit orchards and olive groves) and forest plantations. Separation of semi-natural and natural forests from plantations is also necessary. To achieve this discrimination, several data layers are needed, with these listed in Table E1.3.

Table E1.2 Information layers required for the discrimination of LCCS categories to Level 3.

Feature	Sub-class	Opposite	Sub-class
Vegetation	Photosynthetic Non-photosynthetic Submerged	Not vegetation	
Terrestrial		Aquatic	
Cultivated	Forests plantation Crops Orchards	Natural/semi-natural	Forests Grasslands
Artificial	Water Not-vegetated	Not artificial	Water Not-vegetated

Table E1.3. Data required for the classification of LCCS categories within Levels 1-3.

Broad class	Sub-class	Data layer
Vegetation	Photosynthetic vegetation (PV) Non photosynthetic vegetation (NPV) Submerged aquatic vegetation (SAV)	Normalized Difference Vegetation Index (NDVI); Greenness index Plant Senescence Reflectance Index (PSRI) <sup>1</sup> Green reflectance <sup>2</sup> (following identification of a water surface using the water band indices)
Not vegetation		Opposite of vegetation
Aquatic		Water Band Index (WBI <sub>nir</sub> ) Water Band Index (WBI) Extent of SAV Extent of site-specific habitats (e.g., active bog)
Terrestrial		Opposite of aquatic
Cultivated	Forests Crops Orchards	Spectral/textural classification Commercial forestry maps Cadastral layers Tree counts based on points or delineated crowns with cadastral layers
Not-cultivated		Opposite of cultivated
Artificial	Water Not-vegetated	Hydrology layers (e.g., reservoirs) Infrastructure layers
Not artificial	Water Not-vegetated	Opposite of artificial (water) Opposite of artificial (not-vegetated)

<sup>1</sup>The PSRI can only be calculated from Worldview, as data are acquired in the red edge channel. The use of spectral unmixing to obtain the photosynthetic and non-photosynthetic fraction is an alternative if only Quickbird data are available; <sup>2</sup>Following identification of a water surface using the water band indices.

The **Normalised Difference Vegetation Index (NDVI)** is a measure of plant productivity that relates to the amount and vigor of green vegetation and is defined using:

$$NDVI = \frac{(r_{nir} - r_{red})}{r_{nir} + r_{red}} \quad \text{Equation 3}$$

with values > 0 normally associated with vegetation. Using the Worldview sensor, the wavelengths centered at 659 nm (red) and 831 nm (NIR1) are used in the calculation of the NDVI. In reality, vegetated areas often support a minimum NDVI varying from > 0.1 to 0.2 although can be greater than 0.35 (Sofia et al., 0000). Generally, thresholds of the NDVI can be used to map the extent of vegetation. The greenness index can also be used with this being:

$$Greenness = \frac{r_{green}}{r_{nir}} \quad \text{Equation 4}$$

Spectral unmixing of visible and near infrared (and also shortwave infrared) data can be achieved to obtain endmember fraction images, including for **photosynthetic vegetation (PV)**, **non-photosynthetic vegetation (NPV)** and **shade/moisture (SM)** (Adams et al., 1995). The PV fraction can also be used to define the extent of vegetation, although values vary. The NPV fraction is, however, particularly useful for defining the extent of senescent or dead vegetation, particularly in the drier or colder months (e.g., in Italy and Wales respectively).

An alternative index for considering the amount of dead material is the **Plant Senescence Reflectance Index (PSRI)** where:

$$PSRI = \frac{r_{659} - r_{478}}{r_{724}} \quad \text{Equation 5}$$

and  $\rho_{478}$ ,  $\rho_{659}$  and  $\rho_{724}$  represent the blue, red and red edge bands of the Worldview II respectively. The PSRI range for green vegetation is typically -0.1 to 0.2 and an increase in PSRI indicates increase in canopy stress (associated with an increase in carotenoids). A limitation is that this index cannot be generated from Quickbird data.

For detecting submerged aquatic vegetation at the water surface, Cho *et al.* (2008) suggested that the conventional NDVI could be used but this was less successful in detecting live vegetation under water or vegetation submerged during flooding (even if shallow). However, the index values could be improved by including ground truth information on the spectral reflectance attenuation caused by the water volume. Better detection was achieved using hyperspectral imagers, particularly when using  $\rho_{450}$  and  $\rho_{600}$  (Hakvoort et al., 2002; Governder et al., 2006). Submerged vegetation, if photosynthetic, typically supports a high green reflectance and so once water areas have been identified, its extent can be mapped using data acquired in this wavelength region.

The water band indices (WBI) relate to the amount of water contained within vegetation and normally require data acquired in the near infrared and shortwave

## D5.2 VHR land cover maps

infrared wavelength regions. In the near infrared regions, however, vegetation with a lower water content has a higher reflectance but as the amount of water increases, the magnitude of absorption around 970 nm increases relative to that around 900 nm. Therefore, the WBI can be adapted for the Worldview II sensor using:

$$WBI_{nir} = \frac{\rho_{831}}{\rho_{908}} \quad \text{Equation 6}$$

where  $\rho_{831}$  and  $\rho_{908}$  represent TOARF in the NIR1 and NIR2 wavebands. Using visible bands, the WBI (BLUE/NIR) can be defined such that:

$$WBI = \frac{\rho_{485}}{\rho_{830}} \quad \text{Equation 7}$$

The NDVI, PSRI and  $WBI_{nir}$  generated for the Worldview II image of Le Cesine, Cors Caron and the Netherlands site are illustrated in Figures E1.1 to E1.3). In all cases, the NDVI highlights areas of highly productive vegetation (evergreen and deciduous broad-leaved woodlands in Italy, improved fields in the Cors Caron April image and forests in the Netherlands. In Italy, high areas of PSRI values are associated with the dry grasslands within the olive groves. In Cors Caron, areas of low productivity are associated with the active raised bog and particularly the margins dominated by purple moor grass (*Molinia Caerulea*), with these being prominent in the PSRI. In the Netherlands, the PSRI highlights the area of sand dune and drier grasslands. The WBI highlights areas of water but confusion with shadowed areas (e.g., associated with olive trees in Italy and coniferous forests in the northern European sites) is evident. Areas of open water associated with the Teifi River but also the artificial pools are particularly well highlighted in the Cors Caron image.

D5.2 VHR land cover maps

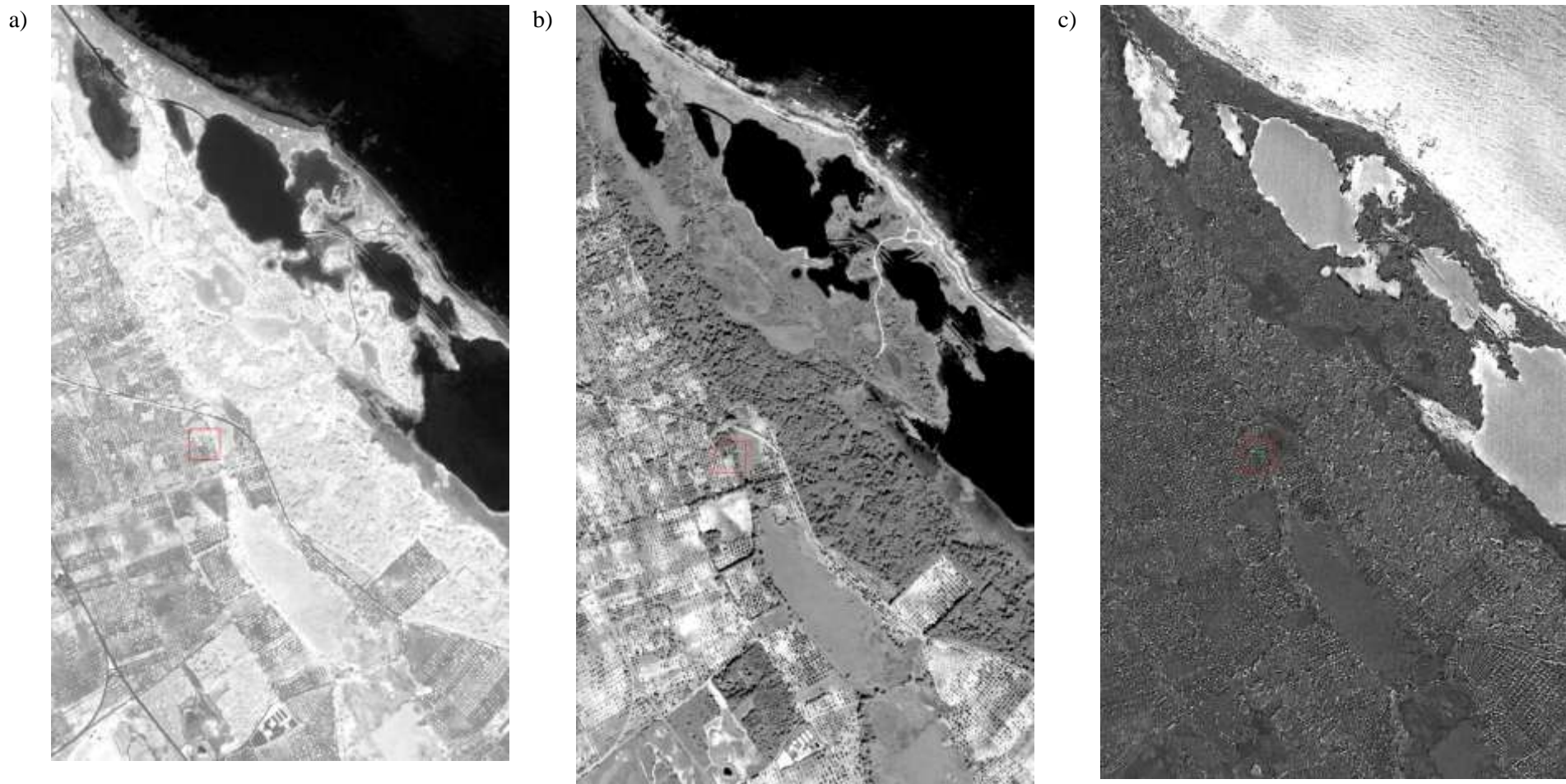

Figure E1.1. a) NDVI, b) PSRI and c) WBI derived from Worldview II images of Le Cesine, Italy.



D5.2 VHR land cover maps

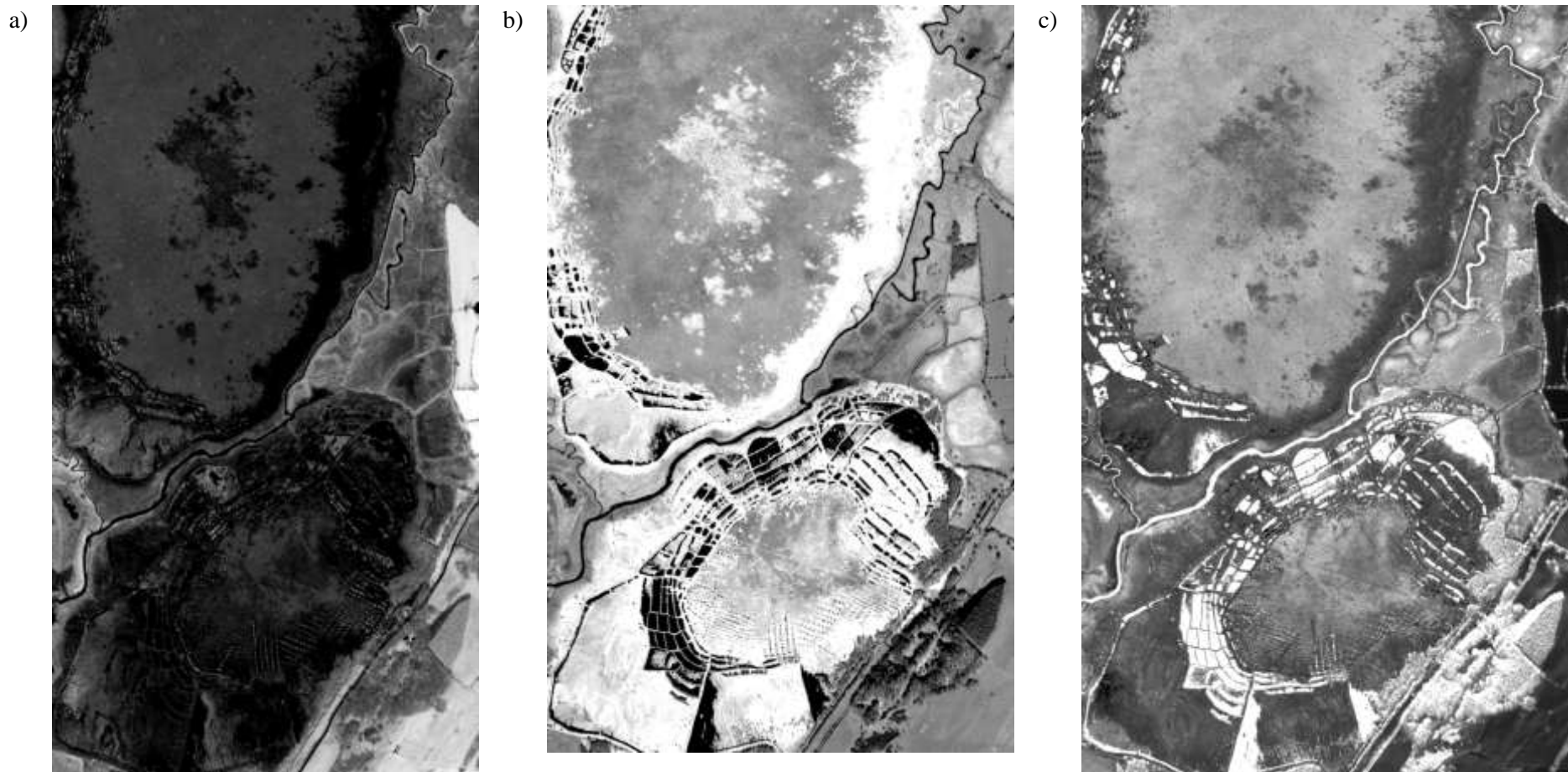

Figure E1.2 a) NDVI, b) PSRI and c) WBI derived from Worldview II images of Cors Caron

D5.2 VHR land cover maps

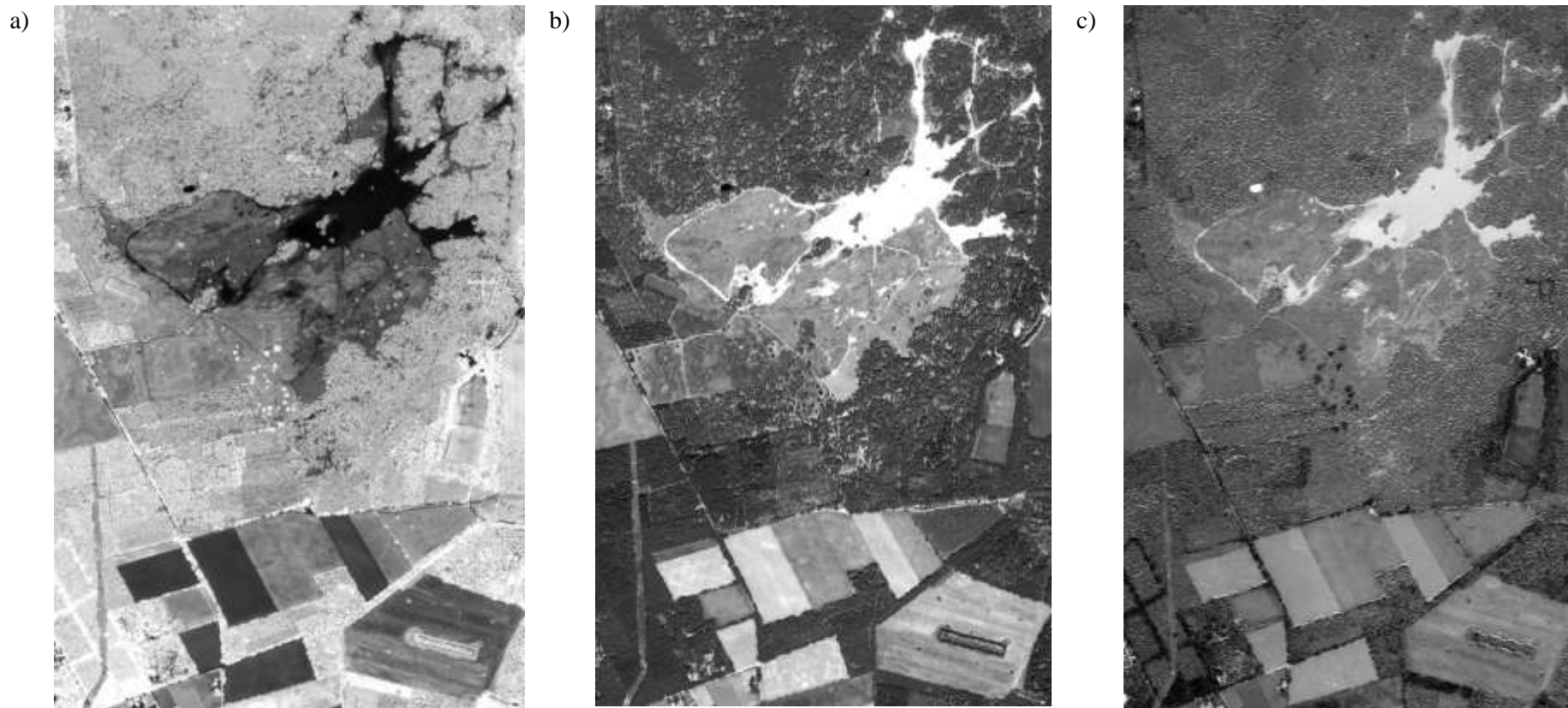

Figure E1.3. a) NDVI, b) PSRI and c) WBI derived from Worldview II images of Wekeromse Zand, the Netherlands

To identify cultivated lands, the study sites in all three countries have cadastral information available as thematic layers, with a number of categories represented. Such information is collected routinely but the frequency of update is variable and the information may be out of data. These thematic layers can provide an initial indication of the extent of cultivated land but may omit some categories (e.g., forestry plantations in Wales) or capture areas that contain semi-natural vegetation. Using VHR imagery, automatic extraction of cultivated land can be achieved where these are relatively homogeneous and are bordered by discrete features (e.g., hedgerows, ditches). Mapping is less easy to achieve, however, where tree crops (e.g. olive groves, orchards) occur as the borders may be as simple as wire fences and only subtle differences between field units are evident. Hence, the requirement for cadastral information is likely to be a prerequisite for mapping LCCS categories. Many forestry plantations are not included within the cadastral layers and commercial forestry data may have to be included, although may be outdated or inaccurate. For this reason, classification from VHR data with reference to existing forestry maps may be useful. Within the existing boundaries, allocation to a tree crop can be achieved by counting and establishing the arrangement of trees based on points (e.g., bright points associated with high sunlit parts of crowns) or delineated crowns (polygons).

For the classification of artificial surfaces, particularly those with urban areas and transport infrastructure, existing **thematic infrastructure layers** may also be utilized although direct classification from the VHR data is desirable. Such information may also include **hydrological layers**, including the location of artificial constructions (i.e., reservoirs). These data can be used for establishing baselines for particular years but then any new expansion of these areas can be identified within the VHR data. For example, new ponds or reservoirs will be identified as they will not occur in the existing baseline but will be detected using, for example, the  $WBI_{nir}$ .

In many cases, the classification of LCCS categories within Level 1-3 can be achieved by taking the inverse of the classification (e.g., non-vegetated as opposed to vegetated, natural as opposed to artificial waterbodies). This approach simplifies the classification of the LCCS categories 1 to 3 but also life forms, physical status and persistence.

### E1.2.3 Feature extraction modules

Within each image, some classes can be extracted automatically based on specific features such as a) size and geometry, b) pattern and c) spatial arrangement, with these often varying depending upon the waveband(s) or derived measures (e.g., vegetation indices) used. Examples of some classes are given in Figure E1.4 and highlight that feature extraction is primarily applicable when classifying man-made environments including buildings and urban infrastructure, agricultural fields, recreational facilities and water bodies. Within all images, considerable diversity is evident which presents a significant challenge to the classification of land covers and habitat categories. In many cases, extracting the components of the observed landscapes (e.g., individual buildings, golf greens, bunkers and fairways) and then combining these with the assistance of semantic nets is essential.

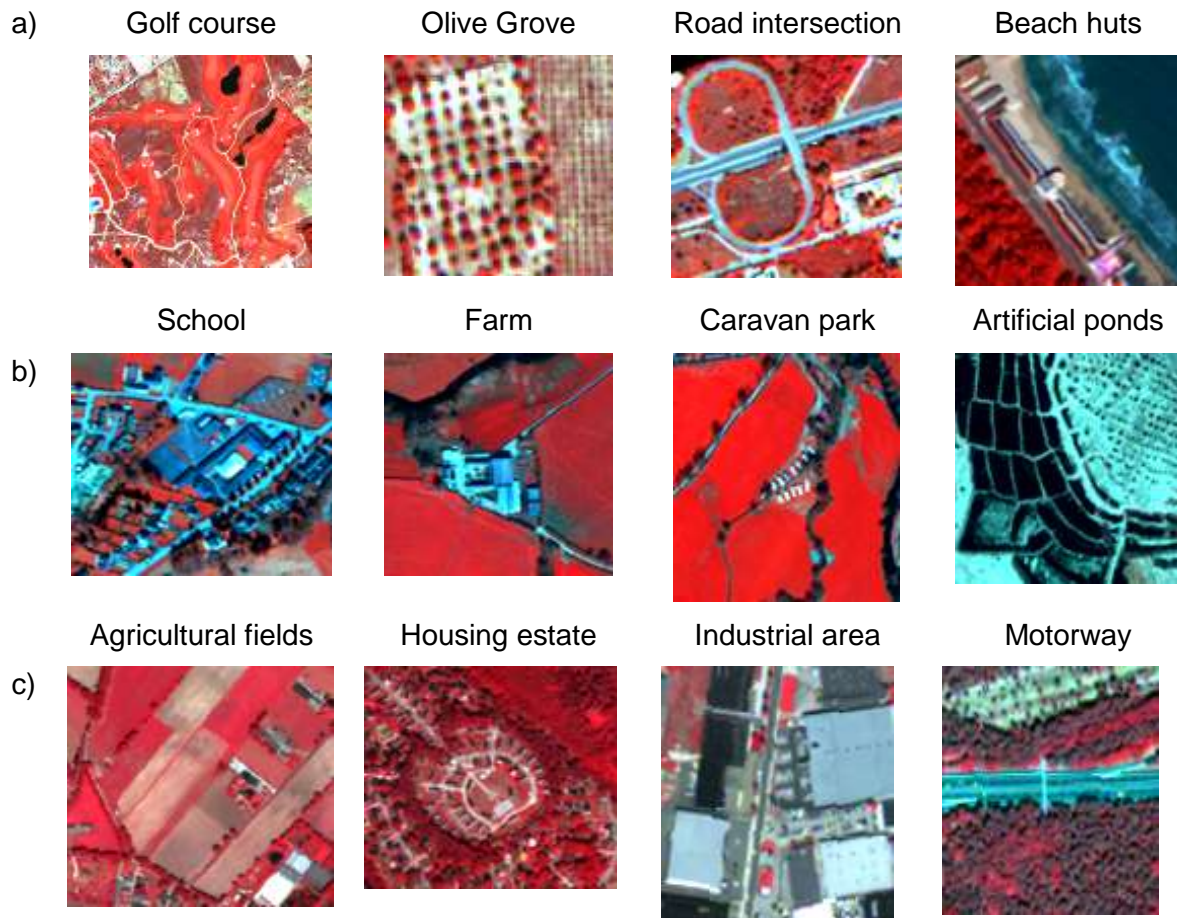

Figure E1.4. Examples of classes evidencing peculiar features, such as oriented texture (for olive grow) and shape identified within the images of a) Le Cesine, b) Tregaron and c) the Netherlands

For feature extraction, appropriate segmentation of the image is required and, within eCognition, available segmentation procedures include chessboard, multi-resolution, contrast filter and spectral difference (following segmentation using, for example, a chessboard). SIAM™ also generates spectral segments, which can be combined subsequently in classification procedures.

#### E1.2.4 Relationships between classes and the importance of semantic nets.

Whilst segments within the image can be extracted and classified based entirely on their spectral characteristics (e.g., water), the classification of LC/LU classes necessarily requires segments to be appropriately combined since at VHR resolution class description related to the selected taxonomy (i.e. LCCS) is not yet sufficient for selected classes. Furthermore, the way that these segments are combined into LCCS categories using remote sensing data can largely mirror the way these are described in the field. In this regard, semantic nets provide an effective and logical method for achieving this as well as a language that can be easily understood. The following three examples show how semantic nets can be used to describe three LCCS categories based on field observations, with these being olive groves

(A1.B1.C1.D1.W8.A7.A9.B3; Monoculture fields of (Permanently cropped area with) rainfed broad-leaved tree crops (plantations) orchards (olive groves)), improved grasslands used for grazing stock (A3.A4.B1.B5.C1.D1.D9\_B4; permanently cropped area: graminoid crop) and a water reservoir (A1.B1.C1.A5; deep to medium deep perennial artificial waterbodies). The challenge for the BIO\_SOS project is to couple this description with one that uses remote sensing data and derived products and other information (e.g., thematic layers, DTMs). A detailed description of the LC/LU class set for the Italian and the Greek sites can be found in PART2 of this deliverable.

**Olive groves:** In Italy, and particularly around the Natura 2000 site of Le Cesine, olive groves are dominant in the agricultural landscape. The olive groves are fields with a regular geometric shape, characterized by broad-leaved evergreen woody crops (e.g.,) an aggregation of at least 20 olive trees of height 2-4 m, which are spaced approximately 10 m, and arranged in rows that are orthogonal and typically oriented in two directions. From March to June, herbaceous vegetation and/or bare soil can be observed depending on farming practices. The semantic net for olive groves, as observed in the field, is given in Figure E1.5.

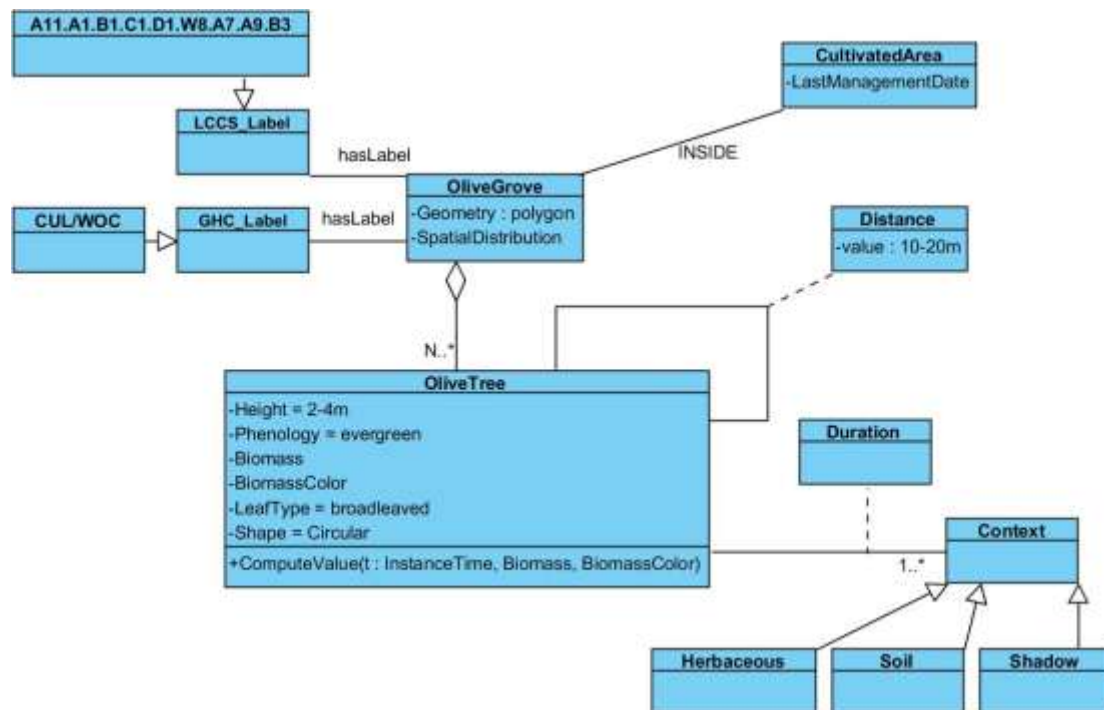

Figure E1.5. Semantic nets for olive groves, Le Cesine, Italy.

**Grazed pastures:** In Wales, permanently cropped area of graminoids are common components of the landscape surrounding Cors Fochno and Cors Caron and the semantic net for these is given in Figure E1.6. First, labels based on the LCCS category (i.e., A3.A4.B1.B5.C1.D1.D9\_B4; associated with the GHCs CUL/CRO and URB/GRA) are assigned. Field-based descriptions are then developed. More specifically, graminoid crops are contained inside a land unit (e.g., a field), are typically less than 1.5 m in height, have a closed continuous canopy and are relatively homogeneous in terms of cover amount and species types. They are typically bright green in appearance although may hay off and become yellow during the drier periods. Fields are typically > several ha in area, regular in shape (e.g.,

rectangular or with at least one straight edge) and bordered by (adjacent to) a linear feature (e.g., a hedge, track or ditch) or another land cover category (e.g., broad-leaved woodland). Productivity may also be consistently high throughout the year or change from a highly productive to a low productivity state because of seasonal drying and/or grazing by stock.

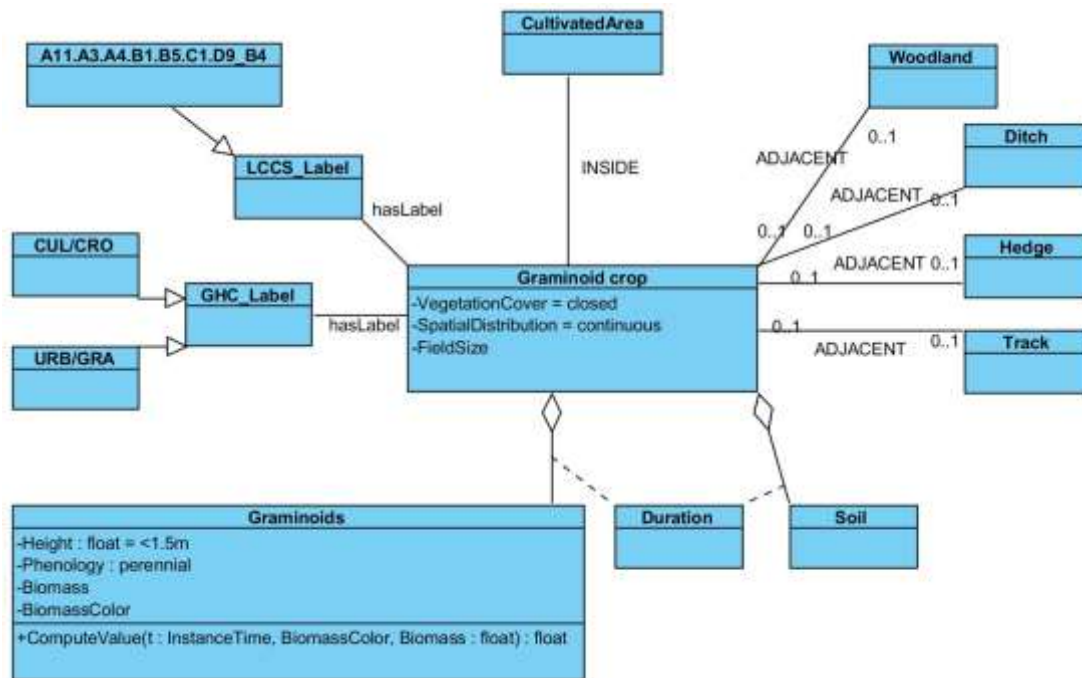

Figure E1.6. Semantic nets for permanently cropped areas of graminoids

**Water Reservoirs:** In many of the BIO\_SOS sites, water reservoirs occur and the semantic net which can be used to separate these from natural waterbodies is given in Figure E1.7.

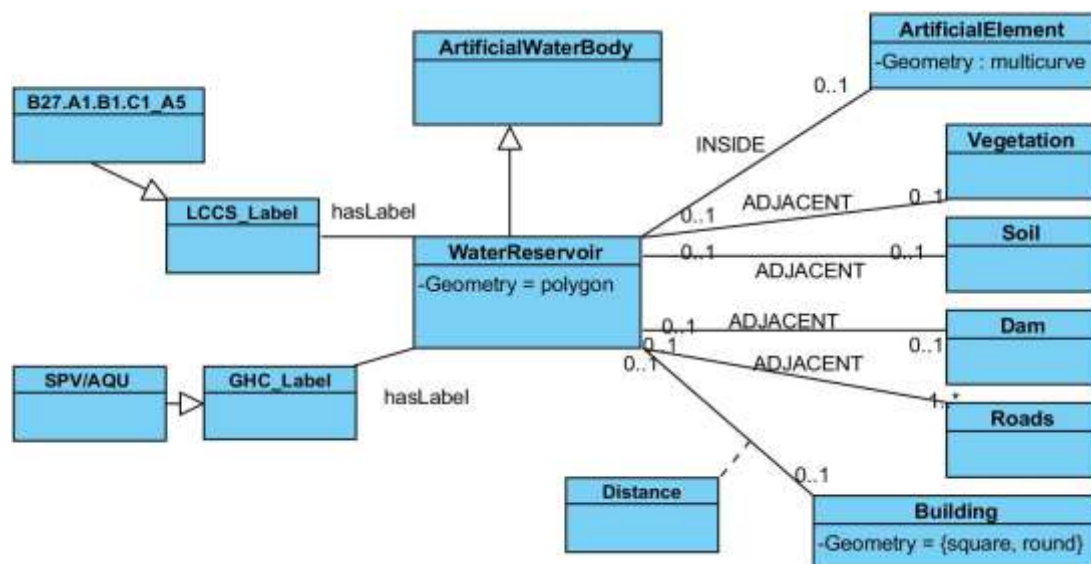

Figure E1.7. Semantic net for a water reservoir.

Reservoirs tend to have an edge of bare ground around the outside and normally one straight or curved edge associated with the dam (e.g., made of concrete or soil). Many reservoirs, particularly those extracting water for drinking, have a tower or similar structure jutting out into the water and are surrounded by vegetation.

For LCCS categories associated with Le Cesine in Italy, Cors Fochno and Cors Caron in Wales and sites in the Netherlands, semantic nets were generated first from an field observer's point of view and subsequently from a remote sensing perspective. It should be noted that further refinement of these shall be undertaken because of the complexity of the environments considered and following collection of field data in ongoing field campaigns.

### E1.2.5. Stratified class-specific fuzzy rule-based classification modules.

In many environments, vegetation mosaics occur and are comprised of continua from one habitat category to another. For example, in Cors Fochno (Figure E1.8), the area of active bog is comprised of several species including *Calluna vulgaris*, *Myrica gale*, *Erica tetralix* and *Eriophorum angustifolium* and towards the margins, these are intermixed with stands of *Phragmites australis* which then become pure. A similar continuum between perennial tall grasslands dominated by *P. australis* and both *Juncus effuses* and *Molinia caerulea* is also observed.

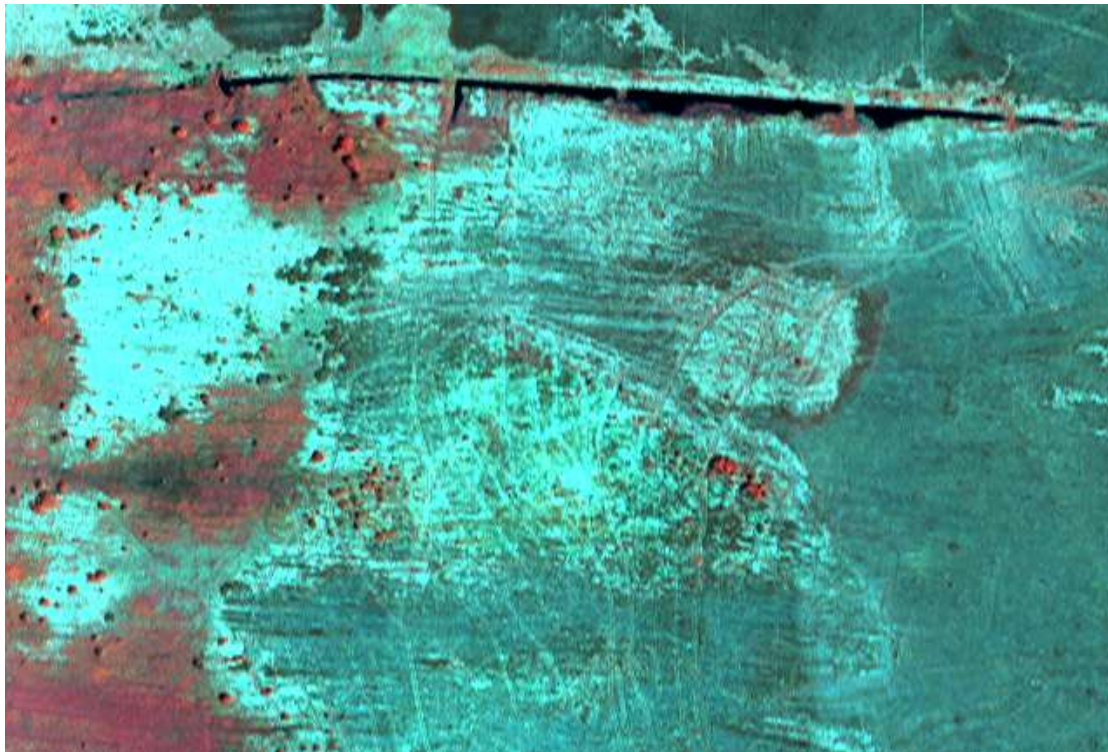

Figure E1.8). Mosaic associated with grasslands dominated by *J. effuses* (red), *P. australis* (cyan) and active bog species (dark grey-blue)

For classification, stratified class-specific fuzzy rule-based classifications can be applied to describe the transitions between vegetation communities but also to indicate relative dominance of a particular species or groups of species. In fuzzy classification, classes are assigned a value ranging from 0 to 1 depending upon certain conditions, with 0 indicating no correspondence (e.g., NDVI < 0) or full

correspondence (e.g.,  $NDVI > 0.5$ ). Membership functions (e.g., linear, non-linear) are then used to describe the transition from the lower to the upper bound (e.g., from the NDVI of 0 to 0.5). Where multiple membership rules and functions are developed, these can be combined in a classification procedure with typically the target class assigned to that with the highest membership function. An example of the application of fuzzy membership to Cors Fochno is given in Figure E1.9.

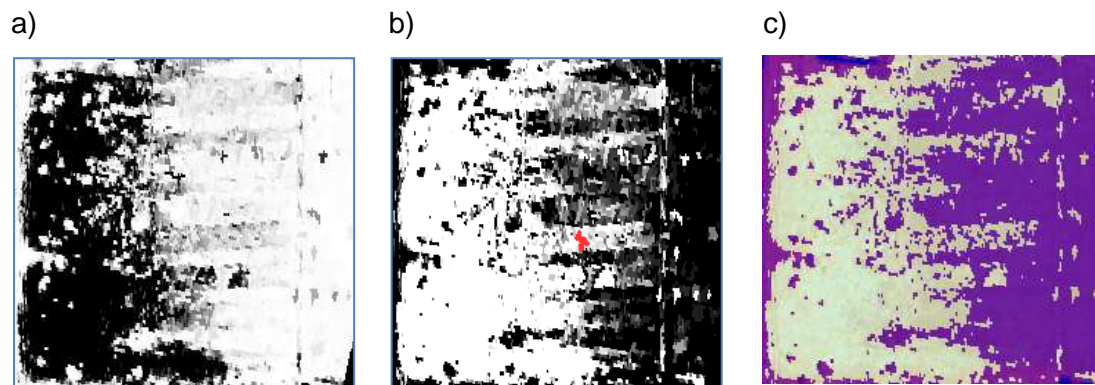

Figure E1.9). Class membership images for a) active bog (closed to open broad-leaved evergreen shrubs with herbaceous vegetation on permanently flooded land; persistent) and b) perennial closed tall grassland on permanently flooded land (permanent) and dominated by *P. australis*. c) Classification based on highest class membership values showing areas identified as a) purple and b) green.

For all sites, a number of LCCS categories were considered as candidates for classification using fuzzy membership, including sand dune complexes in Le Cesine and in proximity to Cors Fochno and the active bog and grassland mosaics at Cors Fochno. As input, spectral bands and derived measures (e.g., NDVI, PSRI, WBI) can be used, as these are indicative of transitions in the biophysical characteristics of vegetation and also non-vegetated surfaces. However, further work though is needed to establish the values and form of the membership functions used.

### E1.3 Overview of accuracy assessment procedures

Although many methods have been developed for thematic accuracy assessment of maps, the most commonly used methods are based on an error matrix, also called a confusion matrix or contingency matrix (Congalton, 1991; Foody, 2002). Contingency tables or error matrices use a cross tabulation with classified EO results on one axis and the reference data on the other. The values in the table consist of users', producers' and overall accuracy. However, this method assumes that the reference data recorded in the field exists of homogeneous plots, which is often not the case for vegetation or habitat recording. Numerous other accuracy measures have been proposed. For example, the *kappa* and *tau* coefficients have also often been associated with assessing classification accuracies. Fitzgerald and Lees (1994) introduced the *Kappa* test statistic, which accounts for chance agreement but Naesset (1999) conveyed that the *tau* coefficient was a more effective measure of assessment. Foody (2011), however, disputed the reliability of the kappa statistic.

Each accuracy measure incorporates different information about the error matrix and therefore must be examined as different computations attempting to explain the error (Congalton, 1991). Not one measure is universally best for all accuracy assessment objectives, and different accuracy measures may lead to conflicting conclusions because the measures do not represent accuracy in the same way (Stehman, 1997). Most traditional methods used to assess accuracy are, however, inappropriate for



## D5.2 VHR land cover maps

mixed pixels. For example, the site of a field recording (e.g., a plot with a 5 m radius) can be complex and heterogeneous yet can be covered by several pixels of HR or VHR imagery and contain different classes. Alternatively, the same area can be contained within one larger pixel corresponding to only one class. In these cases, a fuzzy classification approach is required (Foody, 1996). Radoux et al. (2010) also considered methods for assessing the classification accuracy of mixed pixels.

Alternative approaches estimate map purities by means of the boolean operator, the multiplication operator and the minimum operator. Although these techniques have not been applied in the current deliverable, they are briefly reviewed here, with a view to incorporating them in future BIOSOS work.

The *boolean operator* based on the dominant category is defined as follows: if the dominant category in the classification equals the dominant category in the reference data, the boolean operator is 1, else the boolean operator is 0.

The *multiplication operator* is based on the assumption that the spatial distribution of the categories in the spatial units is unstructured. More specifically, if  $P_{ni}$  denotes the membership to class  $i$  in the classification data at location  $n$  and  $P_{n\cdot j}$  denotes the membership to class  $j$  in the reference data at location  $n$ , then the multiplication operator is defined as follows (after Pontius and Cheuk, 2006):

$$P_{nij} = P_{ni} \times P_{n\cdot j} \quad \text{Equation 8}$$

The *minimum operator* (Binaghi et al., 1999) is defined as:

$$P_{nij} = \min(P_{ni}, P_{n\cdot j}) \quad \text{Equation 9}$$

The overall accuracy of the vegetation map is estimated from the validation data using the selection probabilities of the sampling elements in the stratified simple random sample and can be considered as the mean of the purities of the validation units.

For each of the BIOSOS test sites, a large number of ground truth datasets were collected during 2011 or collated from existing sources. In many cases, the process of collecting field data with reference to imagery assists the development and implementation of a rule-based classification but the data is not necessarily used to 'train' the classification as in the case of more traditional supervised classifiers. This is largely because the classification is based upon knowledge of the users. Instead, a larger proportion of the dataset can be used to determine the accuracy of the resulting classification.

The number of field sites available for 'training' or 'testing' the classifications is given in Table E1.4. However, and as reported in D4.3, a large number of samples are needed to obtain accuracies above a certain threshold and error tolerance. Whilst field data have been collected for all sites, additional samples require extraction from ancillary information (e.g., previous surveys, aerial photography). Estimates of classification accuracy are therefore currently being developed for each of the test sites and will be reported in full detail D5.4 where a comparison between classifications based on single and multi-date imagery, hyperspectral data and/or LiDAR will be undertaken.

## D5.2 VHR land cover maps

Table E1.4) Number of field sites available for testing the classifications for the a) Italian, b) Welsh and c) Dutch sites based on sampling undertaken as part of the BIOSOS project.

<b>Site</b>	<b>No. plots</b>
Le Cesine	NA
Cors Fochno	178
Cors Caron	101
The Netherlands	94

### E1.4 Overview

In the development of the classification of LCCS for each site, considerable effort has focused on the collation and collection of appropriate and sufficient ground truth through on-site field campaigns and through a stratified sampling approach. VHR and also hyperspectral data have been obtained (including through targeted acquisitions) and appropriately calibrated to TOARF or surface reflectance (in the case of the hyperspectral data). The main LCCS categories have been identified for the test sites at Le Cesine in Italy, Cors Fochno and also Cors Caron in Wales and the Netherlands and field-based descriptions have been documented within semantic nets, with these focusing initially on the LCCS levels 1-3 and then on templates which can be used to more efficiently describe life forms, surface aspect, physical status and persistence at lower levels. This information has been coupled with remote sensing knowledge to advance methods for description and classification from VHR data and ancillary data layers. The requirements for these ancillary data, spectral (from single dates, multi-dates and hyperspectral imagery) information have been considered and a range of techniques for classification have been reviewed, with these based on feature extraction, rules developed within semantic nets and stratified fuzzy classification. Approaches to accuracy assessment have been reviewed and the components of the EODHAM 2<sup>nd</sup> stage have been considered. Section F provides preliminary maps and assessments of accuracy based on the resulting output maps for Le Cesine, Cors Fochno and Cors Caron and the Netherlands and a discussion of these is given in Section G.

## F1. VHR classifications of LC/LU categories in LCCS

For the Italian, Welsh and Dutch test sites, classifications were initially undertaken to LCCS Level 3, with the similar series of input data used. For the classification of life forms but also non-vegetated categories, rules that were more site-specific were necessarily developed because of the different habitats occurring (e.g., active bogs in Wales and wetland habitats in Italy). For the classifications, the following were used:

- Dual season Worldview II and Quickbird imagery (Le Cesine, Italy)
- Single-date Worldview II images acquired in the spring (Cors Caron, Wales), summer (the Netherlands) and autumn (Cors Fochno, Wales).

The following sections provide an overview of the approach to classifications to Level 3 and templates used for more detailed classification of life forms and non-vegetated surfaces are also outlined and justified. For each site, maps of Level 1 to 3 categories and also more detailed classifications are then presented together with estimates of classification accuracy for some, although this assessment process is ongoing.

### F1.1 Two-stage classifications with a 1<sup>st</sup> stage based on SIAM™ preliminary spectral mapping.

#### F1.1.1 EODHaM 1st stage: SIAM™ preliminary spectral mapping

For the Italian site, EODHaM 1<sup>st</sup> stage SIAM™ preliminary spectral maps were available for both the Quickbird and Worldview-2 images and these, together with the original input images from which they were derived, are shown in Figures F1.1 and F1.3 for Quickbird and WorldView2 respectively. Figures 1.2 show the vegetation strata from Quickbird SIAM™ and a zoomed area showing how same spectral categories, due to the limited number of spectral bands, corresponds to both high and low vegetation. Class sampling regions were extracted from a pre-existing LC/LU map, already used in D5.1 for GHC mapping, to identify reference spectral categories per each class including core and context spectral categories according to the class description in PART 2.

Concerning the 8 band Worldview-2 image, it is worth noting that the SIAM™ 1<sup>st</sup> stage module can process only the 4 bands equivalent to those occurring in the Quickbird imagery. The SIAM output super-categories found in the Le Cesine site are: a) *either water or shadow*, b) *either bare soil or built up*, c) *vegetation*. The remaining super-categories (snow or ice, clouds and outliers) are not present.

It is worth noting that the mapping between the spectral sub-categories and the final land cover (LC) and land use (LU) classes is generally *one-to-many* and *many-to-many* largely because of the availability of only 4 spectral bands at the VHR. This is particularly the case for vegetation strata, whose 30 spectral sub-categories are not useful for final class discrimination, since the same spectral categories correspond to different final classes, as well evidenced in Table F1.1

In the first instance, the classification of land covers was undertaken by developing a complex ruleset that first sought to discriminate the various land cover categories and then amalgamate these into a map representing the LCCS categories. An overview of this procedure is outlined in the following sections.

Table F1.1. Semantic consistency of reference class samples with spectral categories: a) *Quickbird* and b) *Worldview2* SIAM™ output map. Sample occurrences in %

Table F1.1.a) QuickBird		Monoculture fields of rainfed needleleaved evergreen tree crops orchards	Monoculture fields of rainfed broadleaved evergreen tree crops orchards	Fields of irrigated no graminoids crops		Broadleaved deciduous medium high closed shrubland	Needleleaved evergreen medium high closed shrubland	Broadleaved evergreen cistus erica open dwarf shrubland	Closed annual medium tall forbs	Open annual short herbaceous vegetation	Open annual short forbs	Open perennial medium tall grasslands	Aphyllous closed dwarf shrubs on temporally flooded land	Open annual short herbaceous vegetation on temporarily flooded lands	Perennial sparse medium tall herbaceous vegetation on permanently flooded lands	Perennial closed tall grassland on temporally flooded lands	Perennial closed medium tall grassland on temporarily flooded lands	Paved Roads	Scattered industrial or other areas
LCCS Class Sets (1:5000)	A11A1B 1C1D1 W7A8A 9B3	A11A1B 1C1D1 W8A7A 9B3	A11A3A 5B2C2D 3	A12A1A 4A10B3 D1E1B9	A12A1A 4A10B3 D1E2B9	A12A1A4 A10B3D2E 1B9	A12A1A 4A11B3 D1E1B1 0	A12A2A 5A10B4 E5B12E 6	A12A2A 5A11B4 E5A13B 13E6	A12A2A5 A11B4E5B 13E6	A12A2A6 A11B4E5B 12E7	A24A1A4 A12B3C2D 3B10	A24A2A5 A13B4C2E 5B13E6	A24A2A5 A16B4C1E 5A15B12E 7	A24A2A6 A12B4C2E 5B11E7	A24A2A6 A12B4C2E 5B12E7	B15A1A3 A7A8	B15A1A4 A12A17	
<b>Vegetation Strata</b>																			
1	SVVH2NIR			0.01												0.03			
2	SVVH1NIR		0.05	0.23	0.19	2.52	0.04	0.10	0.24			0.02		0.20		0.09	2.17	0.19	
3	SVVHNIR	0.09	0.21	1.56	0.84	<b>12.05</b>	1.07	0.62	0.90			0.07		0.48		0.57	<b>9.80</b>	0.36	0.10
4	SVHNIR	2.97	1.35	1.34	<b>11.52</b>	<b>8.38</b>	2.02	<b>5.88</b>	0.98	0.52		0.17		1.29	0.02	2.11	<b>12.20</b>	1.02	0.50
5	SVMNIR	2.47	1.15	0.03	<b>5.81</b>	0.54		1.57	0.05	0.26				0.24	0.02	0.30	2.28	0.49	0.20
6	SVLNIR	0.06	0.01		0.03	0.03		0.01									0.07	0.01	
7	SVVLNIR																		
8	AVVH1NIR		0.00																
9	AVVHNIR		0.03	0.67	0.01	0.96	0.27	0.03	0.20			0.03		0.24		0.03	0.50	0.20	0.20
10	AVHNIR																		
11	AVMNIR																		
12	AVLNIR																		
13	AVVLNIR																		
16	SHRWE	0.59	0.24	0.11	0.10	0.02		0.01	0.01					0.13	<b>9.64</b>	0.60	0.59	0.38	0.40
17	SHV_WEDR			0.01										0.03	0.01			0.02	0.20
18	SSHRBR																		
19	ASHRBR VH1NIR																		
20	ASHRBR VHNIR																		
21	ASHRBR HNIR	0.55	1.54	<b>6.85</b>	2.72	<b>23.53</b>	<b>11.20</b>	1.93	<b>3.55</b>	1.12		0.69	0.99	<b>4.25</b>	0.03	<b>3.92</b>	<b>12.96</b>	2.92	<b>1.41</b>
22	ASHRBR MNIR	<b>15.79</b>	<b>16.93</b>	<b>19.49</b>	<b>36.97</b>	<b>29.61</b>	<b>18.50</b>	<b>25.31</b>	<b>10.19</b>	<b>25.97</b>	0.09	<b>6.43</b>	<b>16.01</b>	<b>19.85</b>	0.57	<b>25.42</b>	<b>26.25</b>	<b>19.87</b>	<b>12.40</b>
23	ASHRBR LNIR	<b>50.92</b>	<b>22.41</b>	<b>14.47</b>	<b>30.22</b>	<b>17.86</b>	<b>3.67</b>	<b>33.80</b>	<b>13.16</b>	<b>67.99</b>	0.02	<b>3.96</b>	<b>33.20</b>	<b>11.58</b>	<b>3.59</b>	<b>31.35</b>	<b>19.45</b>	<b>16.92</b>	<b>10.69</b>
24	ASHRBR VLNIR	<b>24.94</b>	<b>6.58</b>	1.64	2.14	1.37		0.87	0.45	<b>3.45</b>		0.01	<b>5.53</b>	0.57	<b>7.19</b>	<b>13.49</b>	<b>8.56</b>	<b>5.03</b>	2.72
25	AHRBCR																		
29	PB_LSC	0.04	1.16	<b>5.36</b>	0.22	0.40	2.37	0.10	0.53		0.01	0.57	0.79	0.39		0.07	0.88	1.69	2.22
30	GH_CL_LSC																		

D5.2 VHR land cover maps

Table F1.1 a) QuickBird continued		Monoculture fields of rainfed needleleaved evergreen tree crops	Monoculture fields of rainfed broadleaved evergreen tree crops orchards	Fields of irrigated no graminoids crops	Broadleaved evergreen medium high closed shrubland	Broadleaved deciduous medium high closed shrubland	Needleleaved evergreen medium high closed shrubland	Broadleaved evergreen cistus erica open dwarf shrubland	Closed annual medium tall forbs	Open annual short herbaceous vegetation	Open annual short forbs	Open perennial medium tall grasslands	Aphyllous closed dwarf shrubs on temporally flooded land	Open annual short herbaceous vegetation on temporally flooded lands	Perennial sparse medium tall herbaceous vegetation on permanently flooded lands	Perennial closed tall grassland on temporally flooded lands	Perennial closed medium tall grassland on temporally flooded lands	Paved Roads	Scattered industrial or other areas
LCCS Class Sets (1:5000)	A11A1B1 C1D1W7 A8A9B3	A11A1B1 C1D1W8A 7A9B3	A11A3A5 B2C2D3	A12A1A4A 10B3D1E1 B9	A12A1A4 A10B3D1 E2B9	A12A1A4A1 0B3D2E1B9	A12A1A4 A11B3D1E 1B10	A12A2A5 A10B4E5 B12E6	A12A2A5 A11B4E5 A13B13E6	A12A2A5A1 1B4E5B13E 6	A12A2A6A1 1B4E5B12E 7	A24A1A4A1 2B3C2D3B1 0	A24A2A5A1 3B4C2E5B1 3E6	A24A2A5A1 6B4C1E5A1 5B12E7	A24A2A6A1 2B4C2E5B1 1E7	A24A2A6A1 2B4C2E5B1 2E7	B15A1A3A7 A8	B15A1A4A12 A17	
<b>Soils or Built Up</b>																			
31	VBBB_TNCL		0.01														0.01	0.06	0.40
32	BBB_TNCL	0.06	<b>3.16</b>	<b>3.54</b>	0.19		0.54	0.07	1.09		2.16	<b>3.41</b>	0.59	0.59	0.01	0.05	0.18	<b>3.34</b>	<b>5.95</b>
33	SBBVF_LSC		0.02				<b>7.52</b>		0.01		<b>9.45</b>	<b>11.66</b>	1.78	1.58	0.03	0.08		0.03	0.81
34	SBBF	0.02	0.72	2.18	0.01		2.91		0.51		1.37	<b>5.79</b>	1.19	0.15	0.01	0.05		1.27	<b>3.33</b>
35	SBBNF_LSC	0.17	<b>14.28</b>	<b>17.90</b>	0.43	0.38	<b>9.90</b>	0.51	<b>11.28</b>	0.09	0.94	<b>14.10</b>	<b>5.14</b>	0.66	0.06	0.26	0.51	<b>11.41</b>	<b>9.27</b>
36	ABBF	0.01	0.03	0.05			<b>7.43</b>		0.07		<b>17.80</b>	<b>16.12</b>	<b>8.89</b>	5.80	0.11	0.18	0.02	<b>3.01</b>	1.81
37	ABBF	0.02	0.38	1.16	0.01	0.04	1.70	0.01	1.09		0.33	1.68	<b>3.36</b>	0.79	0.02	0.06	0.01	<b>6.37</b>	1.61
38	ABBNF_LSC	0.28	<b>25.93</b>	<b>20.01</b>	0.69	1.59	<b>6.49</b>	0.30	<b>16.72</b>	0.26	0.33	<b>10.26</b>	<b>6.32</b>	8.29	0.59	2.40	1.11	<b>16.76</b>	<b>14.72</b>
39	DBBVF	0.05	0.08	0.09	0.09	0.01	1.03		0.06		<b>6.49</b>	1.85	<b>8.30</b>	11.49	2.54	1.05		<b>3.70</b>	<b>3.43</b>
40	DBBF	0.32	0.48	0.57	0.23	0.08	0.09	0.01	0.15		0.01	0.03	0.20	1.77	<b>4.84</b>	1.70	0.43	0.97	2.32
41	DBBNF_LSC	0.53	<b>3.03</b>	2.74	0.25	0.63	0.67	0.03	1.25	0.35	0.04	0.31	1.38	9.67	2.58	<b>5.51</b>	0.73	2.41	<b>5.54</b>
42	WBB_LSC																		
43	NIRPBB_LSC																		
44	NIRPSABA_LSC																		
45	SHB_LSC	0.01	0.01												2.66	0.02		0.01	0.10
46	RBA																		
47	BSFAPS																		
48	OBA																		
49	BSFS																		
<b>Water or Shadow</b>																			
50	DPWASH_LSC	0.04			<b>7.25</b>		<b>17.69</b>	<b>28.81</b>	<b>37.26</b>		0.01	<b>3.33</b>		0.72	<b>45.06</b>	<b>10.02</b>	1.25	0.89	
52	TWASH_LSC	0.01			0.04		0.04				<b>33.97</b>	2.02	<b>6.32</b>	<b>10.66</b>	<b>14.63</b>	0.53			0.10
<b>Smoke Plume Strata 56-59 empty</b>																			
<b>To be defined</b>																			
62	SN_CL_BBB_LSC	0.03	0.20		0.03		4.84		0.25		26.99	17.48		8.03	0.06	0.08		0.68	19.56
64	UN3_LSC	0.02	0.01											0.59	5.72	0.03	0.01		
	Total n. of pixels	176014	126027	7931	125142	9022	2233	62949	103193	1159	12893	12100	506	4570	196337	288901	11548	10264	992

D5.2 VHR land cover maps

<b>Table F1.1 b)</b>		Monoculture fields of rainfed needleleaved evergreen tree crops orchards	Monoculture fields of rainfed broadleaved evergreen tree crops orchards	Fields of irrigated no graminoids crops	Broadleaved evergreen medium high closed shrubland	Broadleaved deciduous medium high closed shrubland	Needleleaved evergreen medium high closed shrubland	Broadleaved evergreen cistus erica open dwarf shrubland	Closed annual medium tall forbs	Open annual short herbaceous vegetation	Open annual short forbs	Open perennial medium tall grasslands	Aphyllous closed dwarf shrubs on temporally flooded land	Open annual short herbaceous vegetation on temporally flooded lands	Perennial sparse medium tall herbaceous vegetation on permanently flooded lands	Perennial closed tall grassland on temporally flooded lands	Perennial closed medium tall grassland on temporally flooded lands	Paved Roads	Scattered industrial or other areas
<b>WorldView2</b>																			
LCCS Class Sets (1:5000)		A11A1B 1C1D1 W7A8A 9B3	A11A1B 1C1D1 W8A7A 9B3	A11A3A 5B2C2D 3	A12A1A 4A10B3 D1E1B9	A12A1A 4A10B3 D1E2B9	A12A1A4A 10B3D2E1 B9	A12A1A 4A11B3 D1E1B1 0	A12A2A 5A10B4 E5B12E 6	A12A2A 5A11B4 E5A13B 13E6	A12A2A5A 11B4E5B1 3E6	A12A2A6A 11B4E5B1 2E7	A24A1A4A 12B3C2D3 B10	A24A2A5A 13B4C2E5 B13E6	A24A2A5A 16B4C1E5 A15B12E7	A24A2A6A 12B4C2E5 B11E7	A24A2A6A 12B4C2E5 B12E7	B15A1A 3A7A8	B15A1A 4A12A1 7
<b>Vegetation Strata</b>																			
1	SVVH2NIR			0.07		0.01													0.03
2	SVVH1NIR		0.04	0.97	0.03	0.23	0.12	0.01	0.09					0.69		0.02	0.04	0.05	0.19
3	SVVHNIR	0.11	0.14	0.64	0.42	1.11	1.09	0.12	0.38			0.07		1.34		0.14	0.52	0.23	0.24
4	SVHNIR	0.90	0.42	0.28	3.85	0.65	2.35	1.50	0.17	0.18				0.23		0.23	0.86	0.71	0.11
5	SVMNIR	0.14	0.04	0.04	0.65	0.01	0.06	0.11	0.01	0.06				0.02		0.02	0.04	0.05	0.02
6	SVLNIR																		
7	SVVLNIR																		
8	AVVH1NIR		0.02	0.07	0.01	0.19	0.03		0.02					0.03		0.01	0.16	0.07	0.02
9	AVVHNIR	0.18	0.41	1.98	0.19	2.68	0.51	0.08	0.67	0.12		0.05		2.19	0.01	0.18	2.22	0.91	0.73
10	AVHNIR																		
11	AVMNIR																		
12	AVLNIR																		
13	AVVLNIR																		
16	SHRWE	2.61	1.59	0.60	0.58	0.49	0.06	0.23	0.26	0.36	0.26				3.12	0.96	2.30	3.13	2.06
17	SHV_WEDR	4.02	5.33	1.32	1.27	0.47	1.26	0.59	0.72	0.36	0.86	0.18	5.12	0.41	5.88	10.01	1.72	3.77	2.57
18	SSHRBR																		
19	ASHRBR VH1NIR																		
20	ASHRBR VHNIR																		
21	ASHRBR HNIR	5.75	4.92	14.65	8.54	30.75	16.02	4.69	8.27	2.96		1.73	4.09	8.43	0.22	7.51	25.15	6.90	9.77
22	ASHRBR MNIR	28.39	21.26	24.29	39.81	40.45	34.43	32.80	26.36	26.57	0.01	4.35	15.79	13.26	0.89	31.59	32.20	12.84	11.78
23	ASHRBR LNIR	38.31	18.50	11.63	33.76	17.43	11.24	51.34	14.19	50.24	0.01	1.80	16.23	7.84	1.56	31.28	18.50	9.38	3.80
24	ASHRBR VLNIR	13.39	4.18	0.81	5.38	1.49	0.21	4.36	0.51	13.47		0.02	1.61	0.54	0.11	2.69	6.85	3.30	0.57
25	AHRBCR		0.01	0.01			0.01											0.03	0.02
29	PB_LSC	0.09	1.18	1.95	0.11	0.13	0.82	0.10	0.90		0.01	0.58	0.29	1.01	0.02	0.07	0.64	1.53	1.50
30	GH_CL_LSC																	0.02	

D5.2 VHR land cover maps

Table F1.1 b) WorldView2 continued		Monoculture fields of rainfed needleleaved evergreen tree crops orchards	Monoculture fields of rainfed broadleaved evergreen tree crops orchards	Fields of irrigated no graminoids crops	Broadleaved evergreen medium high closed shrubland	Broadleaved deciduous medium high closed shrubland	Needleleaved evergreen medium high closed shrubland	Broadleaved evergreen cistus erica open dwarf shrubland	Closed annual medium tall forbs	Open annual short herbaceous vegetation	Open annual short forbs	Open perennial medium tall grasslands	Aphyllous closed dwarf shrubs on temporarily flooded land	Open annual short herbaceous vegetation on temporarily flooded lands	Perennial sparse medium tall herbaceous vegetation on permanently flooded lands	Perennial closed tall grassland on temporarily flooded lands	Perennial closed medium tall grassland on temporarily flooded lands	Paved Roads	Scattered industrial or other areas
<b>Soils or Built Up</b>																			
31	VBBB_TNCL	0.00	0.00		0.00				0.00			0.00				0.00	0.01	0.08	0.03
32	BBB_TNCL	0.08	2.28	2.37	0.11	0.02	0.77	0.13	2.28		0.08	2.16	0.15	0.37	0.00	0.04	0.75	1.55	<b>4.66</b>
33	SBBVF_LSC	0.04	0.23	1.82	0.03	0.02	1.31	0.02	0.23		1.38	<b>4.41</b>	1.17	1.17	0.02	0.06	0.09	<b>4.32</b>	2.23
34	SBBF	0.07	<b>4.69</b>	<b>4.24</b>	0.10	0.03	0.51	0.19	<b>3.99</b>		0.31	2.71	2.92	0.81	0.02	0.05	0.27	2.14	4.29
35	SBBNF_LSC	0.30	<b>11.69</b>	<b>8.38</b>	0.69	0.34	<b>4.87</b>	1.00	<b>15.88</b>		0.34	<b>6.43</b>	<b>4.09</b>	3.33	0.06	0.36	1.30	<b>6.77</b>	<b>17.50</b>
36	ABBF	0.05	0.93	<b>4.32</b>	0.06	0.06	<b>5.96</b>	0.04	0.85		<b>3.19</b>	<b>16.49</b>	<b>7.60</b>	<b>5.16</b>	0.17	0.23	0.20	<b>11.27</b>	<b>4.39</b>
37	ABBF	0.06	<b>3.52</b>	<b>4.07</b>	0.11	0.20	1.52	0.16	2.91	0.06	0.36	2.55	1.32	2.61	0.07	0.19	0.17	1.40	1.22
38	ABBNF_LSC	0.70	<b>12.56</b>	<b>8.61</b>	2.06	1.97	<b>5.79</b>	1.54	<b>18.17</b>	<b>3.38</b>	0.54	<b>7.74</b>	<b>10.23</b>	<b>9.64</b>	1.36	<b>5.41</b>	1.50	<b>4.77</b>	<b>5.38</b>
39	DBBF	0.10	1.35	1.86	0.10	0.09	3.03	0.04	0.72	0.00	1.05	<b>3.69</b>	1.17	<b>5.77</b>	<b>3.26</b>	1.88	0.19	<b>3.91</b>	2.20
40	DBBF	0.23	1.29	0.62	0.28	0.26	0.43	0.08	0.34	0.00	0.09	0.27	1.17	<b>3.59</b>	0.90	1.62	0.27	0.54	0.40
41	DBBNF_LSC	0.27	0.84	0.52	0.41	0.26	0.12	0.11	0.42	0.24	0.00	0.02	2.78	0.69	0.55	<b>3.18</b>	0.19	0.23	0.33
42	WBB_LSC																		
43	NIRPBB_LSC																		
44	NIRPSABA_LSC																		
45	SHB_LSC	0.27	0.19	0.05	0.07	0.07		0.08	0.08	0.60				0.03	0.09	0.02	0.37	0.81	0.24
46	RBA																		
47	BSFAFS																		
48	OBA																		
49	BSFS																		
<b>Water or Shadow</b>																			
50	DPWASH_LSC	0.05	0.09	0.33	0.20	0.02	0.24	0.01	0.03		1.88	0.53	0.15	<b>11.67</b>	<b>78.00</b>	1.54	0.12	1.24	0.29
52	TWASH_LSC	0.01	0.06	0.05	0.12	0.01	<b>4.11</b>	0.00	0.05		<b>46.59</b>	<b>16.79</b>	<b>22.51</b>	<b>10.50</b>	<b>3.52</b>	0.47	0.16	<b>8.15</b>	<b>3.71</b>
<b>Smoke Plume 56-59 empty</b>																			
<b>To be defined</b>																			
	SN_CL_BBB_LSC	0.09	0.97	3.16	0.12		2.71	0.09	1.32		<b>42.23</b>	<b>27.09</b>	1.32	<b>8.55</b>	0.05	0.16	0.81	<b>8.32</b>	<b>19.37</b>
64	UN3_LSC	<b>3.79</b>	1.29	0.27	0.93	0.55	0.43	0.57	0.17	1.39	0.82	0.26	0.29	0.12	0.10	0.10	2.39	1.58	0.36
	<b>Total n. of pixels</b>	<b>372764</b>	<b>181411</b>	<b>11412</b>	<b>207936</b>	<b>17139</b>	<b>7233</b>	<b>130869</b>	<b>182667</b>	<b>1656</b>	<b>20286</b>	<b>27321</b>	<b>684</b>	<b>6515</b>	<b>282273</b>	<b>489938</b>	<b>20332</b>	<b>20732</b>	<b>6314</b>

### **F1.1.2 EODHaM 2nd stage for LC/LU mapping.**

#### F1.1.2.1 Class specific features and data selection

Multi-temporal rules based on phenology information and context-sensitive features as well as external (ancillary) data were mainly used, according to the class description provided in PART B, to *discriminate classes belonging to the super categories (strata) characterizing the scene (either water or shadow, either bare soil or built up, or vegetation)*. The 2<sup>nd</sup> stage stratified classification algorithm was implemented in eCognition Developer 64 (made available at CNR\_ISSIA by RIVONA project) with a stratified (hierarchical) approach and using the SIAM<sup>TM</sup> spectral categories.

The set of features and external data used within each strata of the SIAM first stage, for class discrimination in the EODHaM 2nd stage are synthetized in Table F1.2. For each class belonging to a specific stratum, the class core/context spectral categories used for class identification as well as class specific features, are reported in the Table. LC/LU classes at the LCCS Dichotomous Level 3 and the subsequent hierarchical levels can be obtained.

Many classes associated with a high spectral reflectance (e.g., paved roads, sand) are generally able to be discriminated using spectral categories belonging to the SIAM 1<sup>st</sup> stage output map. However, within Le Cesine, many buildings were sparse and small and hence approach was less successful.

The resulting classifications are shown in Figure F1.4 (all classes) with these summarised to LCCS levels 1-3 in Figure F1.5. The rules are discussed in Section F1.1.2.2.



a)



b)



Figure F1.1. a) Quickbird image of Le Cesine obtained in June, 2009 (red, near infrared and blue in RGB). b) The output SIAMTM map of 52 spectral categories generated from the same image. The red line represents the Natura 2000 site boundary.

a)

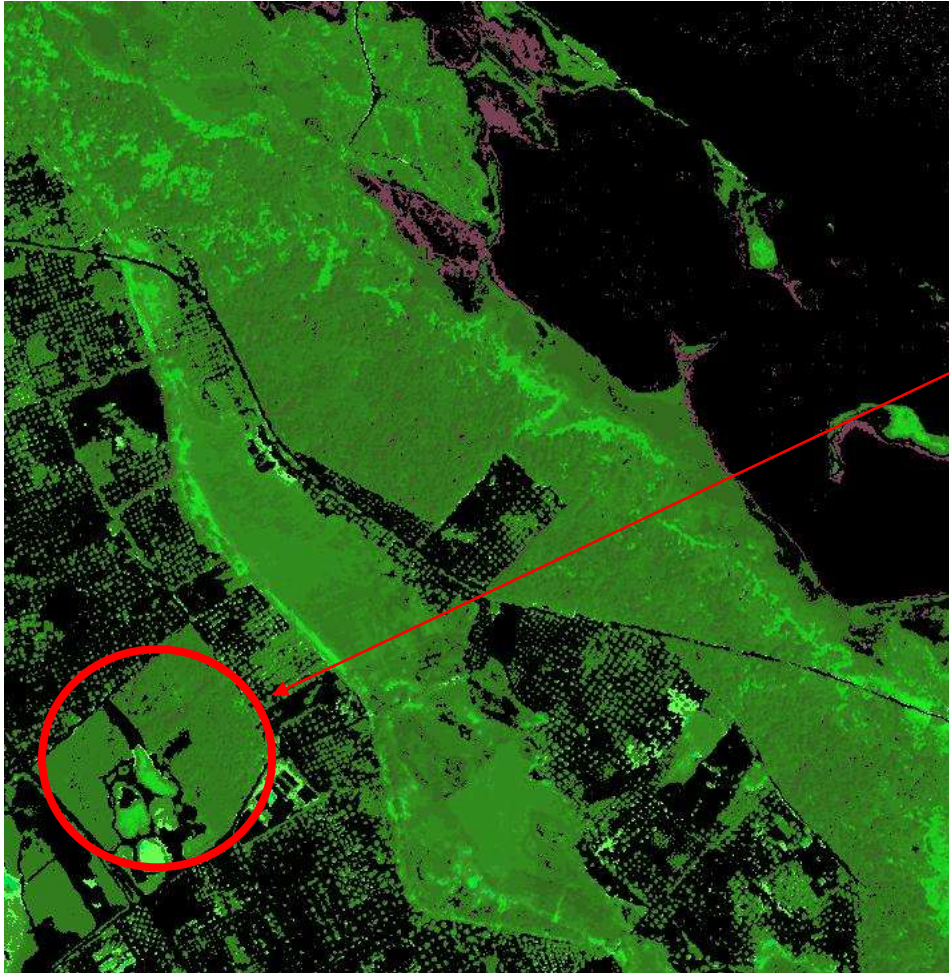

b)



Figure F1.2 a) SIAM 1<sup>st</sup> stage output map. Only the vegetation strata is shown with its spectral semantic sub-categories (1 to 30), which include vegetation in shadow, dark vegetation (16, 17) and wetland (29, 30). See [SIAM™ manual] for spectral categories description and look-up. b) sub-windows of the original image and its corresponding spectral map.

a)



b)



Figure F1.3. a) Worldview II image acquired at 2.4 m spatial resolution in October, 2009 (red, near infrared and blue in RGB). b) The output SIAMTM map of 52 spectral categories generated from the same image. The red line represents the Natura 2000 site boundary.

D5.2 VHR land cover maps

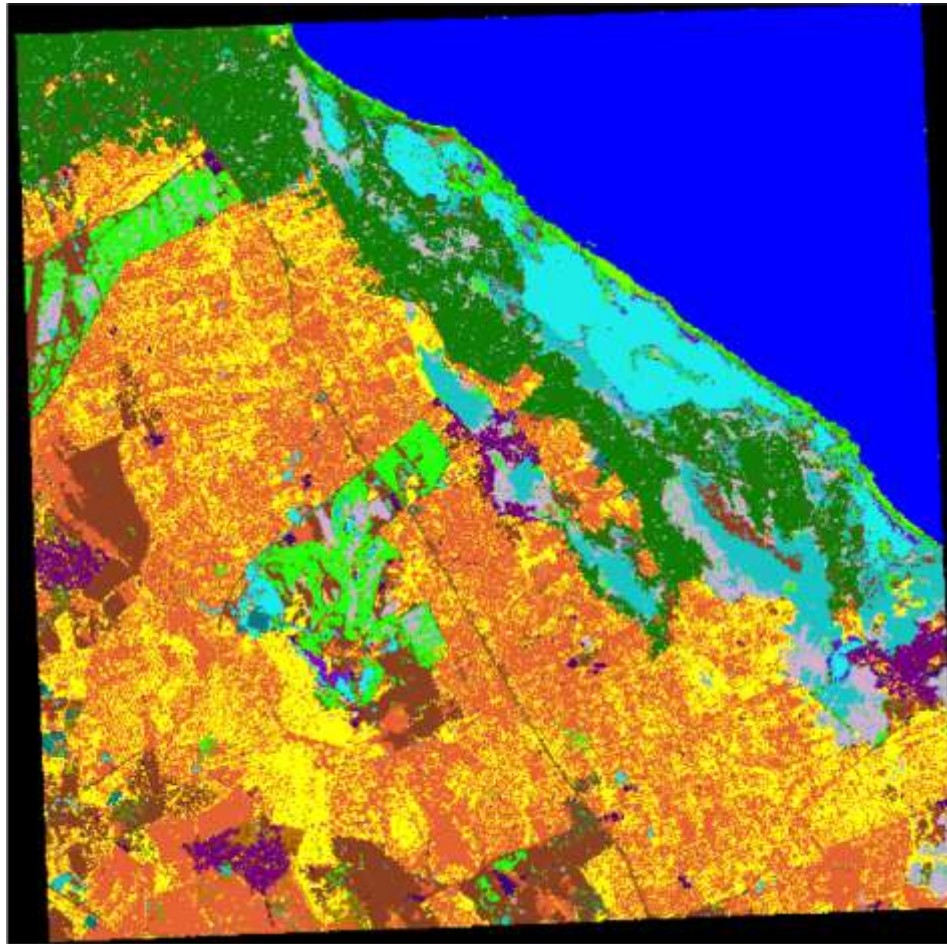























	LCCS Label	Look-up
B28	A1	
BBBB		
B15	A1.A4.A13.A17	
B15	A1.A3.A7.A8	
HTV		
A24	A2.A5.E6	
A24	A2.A6.E6	
A24	A1.A4.D3	
A11	A1.A8.A9.W7	
A11	A1.A7.A9.W8 (core)	
A11	A1.A7.A9.W8 (context)	
A11	A1.A7.A9.W8 (veg. context)	
B15	A1.A3.A7.A9	
A11	A1.A7.A9.W8	
A12	A2.A6.E6	
A12	A1.A4.D1.E2	
A12	A1.A4.D2.E1	
A12	A1.A4.D1.E1	
A24	A2.A5.E7 (habitat 1310)	
A24	A2.A5.E7 (habitat 3170)	
A12	A2.A5.E7 (habitat 1210)	
A12	A2.A5.E7 (habitat E1.6)	
A11	A3.A5	

Figure F1.4. Final output Map at Hierarchical LCCS level images.  
 Additional classes belonging to A24 and A12 were discriminated. Two classes labelled, as BARE SOILS OR BUILT-UP (BBBB) and TEXTURED VEGETATION (HTV), need further analysis.

D5.2 VHR land cover maps





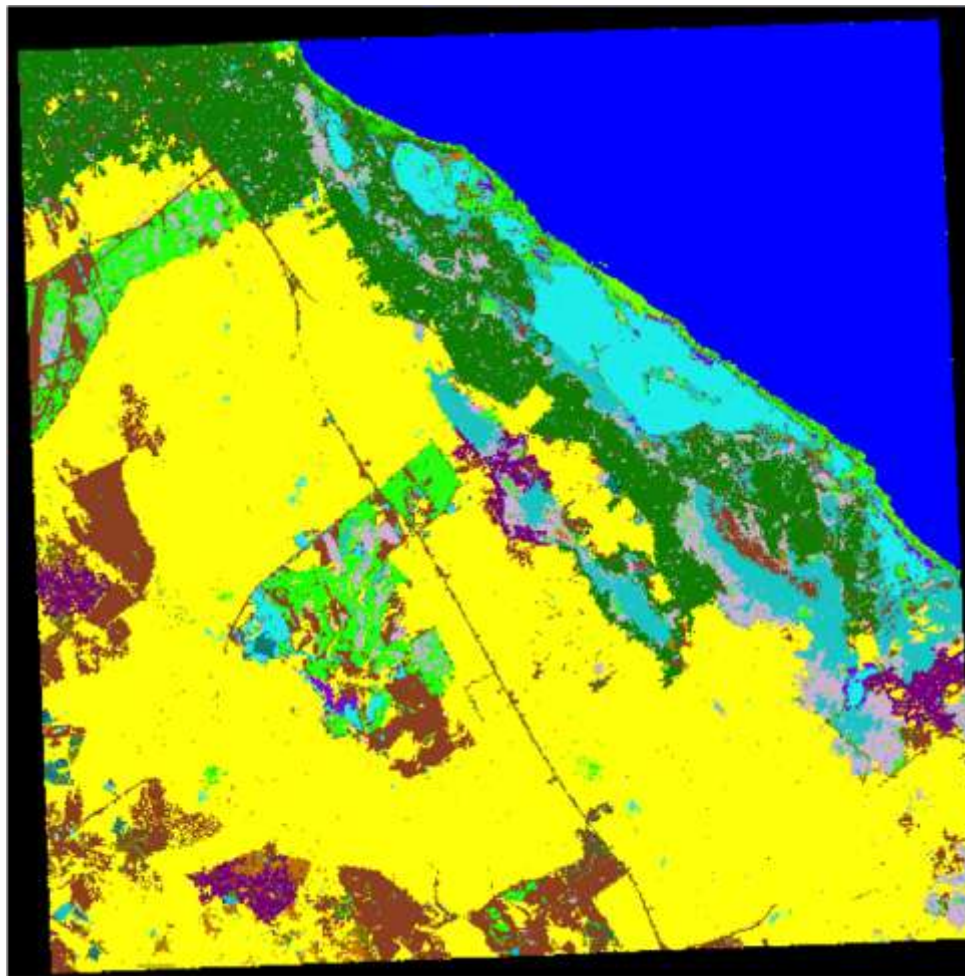

















	LCCS Label	Look-up
B28	A1	
BBBB		
B15	A1.A4.A13.A17	
B15	A1.A3.A7.A8	
HTV		
A24	A2.A5.E6	
A24	A2.A6.E6	
A24	A1.A4.D3	
A11	A1.A8.A9.W7	
A11	A1.A7.A9.W8	
B15	A1.A3.A7.A9	
A11	A1.A7.A9.W8	
A12	A2.A6.E6	
A12	A1.A4.D1.E2	
A12	A1.A4.D2.E1	
A12	A1.A4.D1.E1	
A24	A2.A5.E7 (habitat 1310)	
A24	A2.A5.E7 (habitat 3170)	
A12	A2.A5.E7 (habitat 1210)	
A12	A2.A5.E7 (habitat E1.6)	
A11	A3.A5	

Figure F1.5. Final output Map at Hierarchical LCCS level images (1-3). Additional classes belonging to A24 and A12 were also discriminated. Two classes, labelled as BARE SOILS OR BUILT-UP (BBBB) and HIGH TEXTURED VEGETATION (HTV), need further analysis.

D5.2 VHR land cover maps

Table F1.2. Class specific features and external data used in the second classification stage for class identification

LCCS (Hierarchical)	LCCS (Hierarchical finest)	LCCS - DICOT. (level 3)	Core/Context	SIAM™ output Supercategory considered	SIAM Indexes	Relations				Attributes	
						Themati c Ancillar y	Spatial		Temporal	Textural	Geometric
							Topological	Non Topolog ical			
B28/A1		B28		SIAM WATER OR SHADOW(50 or 52)							Area≥500kpxl
INTERNAL WATER				SIAM WATER OR SHADOW(50 or 52)							Area<500kpxl
A24/A2.A5.E6		A24		INTERNAL WATER	SIAM QB fRatioWater Index≥1		Not adjacency to B28/A1				
B15/A1.A4.A13.A 17		B15		SIAM BARE SOILS OR BUILT- UP(62)							Area≥40pxl Length/Width ≤2.64
B15/A1.A3.A7.A8		B15		SIAM BARE SOILS OR BUILT- UP(36 or 37 or 39 or 62)			Not adjacency to B28/A1 and to INTERNAL WATER and to WET SOIL				Length/Width ≥4
B15/A1.A3.A7.A9		B15		SIAM BARE SOILS OR			Adjacency to A11/A1.A7.A9.W8(core				Length/Width ≥6

D5.2 VHR land cover maps

				BUILT- UP(from 35 to 49 or 62)			) or to A11/A1.A7.A9.W8(cont ext) or to SINGLE TREES				
WET SOIL				SIAM BARE SOILS OR BUILT- UP(from 38 to 42)			Adjacency to B28/A1 or INTERNAL WATER				
A24/A2.A6.E6		A24	Context	WET SOIL			Not adjacency to A24/A2.A5.E6				
SAND				SIAM BARE SOILS OR BUILT- UP(36 or 37 or 62)			Adjacency to B28/A1				
A12/A2.A5.E7	A12/A2.A5.E7 + O3.M233.N3.N12-AR (habitat 1210)	A12	Context	SAND							
A24/A2.A5.E7	A24/A2.A5.E7 + R1.O3.M233 (habitat 3170)	A24		SIAM BARE SOILS OR BUILT- UP(from 31 to 49 or 62)			Adjacency to A11/A1.A7.A9.W8 (core) or to A11/A1.A7.A9.W8 (context)			Asymmetry≤0.25	Compactness ≤2.5
	A24/A2.A5.E7 + R3/R2.O3.M213.N2.N12-SC (habitat 1310)			SIAM BARE SOILS OR BUILT- UP(from 38 to 42)			Adjacency to A24/A2.A5.E6				
A11/A1.A7.A9.W8		A11	Context	SIAM BARE SOILS OR BUILT- UP(from 31 to 49 or 62)		N° overlapping with Cadastral only cultivate map>0	Adjacency to A11/A1.A7.A9.W8 (core)			Green Band QB Entropy (occurrence measure)≥1.35	
HIGH TEXTURED VEGETATION				SIAM Vegetation (from 1 to 30)						Green Band QB Entropy (occurrence measure)≥0.85	

D5.2 VHR land cover maps

LOW TEXTURED VEGETATION				SIAM VEGETATION (from 1 to 30)					Green Band QB Entropy (occurrence measure)<0.85	
SINGLE TREES				HIGH TEXTURED VEGETATION			Adjacency to SIAM BARE SOILS OR BUILT- UP		Green Band QB Entropy (occurrence measure)>1.4	Roundness≤0.4
AQUATIC VEGETATION				LOW TEXTURED VEGETATION	SIAM WV-2 fRatioWater Index≥1				Green Band QB Entropy (occurrence measure)≤0.62	
TERRESTRIAL VEGETATION				LOW TEXTURED VEGETATION	SIAM WV-2 fRatioWater Index<1				Green Band QB Entropy (occurrence measure)>0.62	
GREEN JUNE AND OCT				TERRESTRIAL VEGETATION				VEGETATI ONon SIAM Spectral Categories of WV-2 image≥31		
GREEN JUNE AND NOT OCT				TERRESTRIAL VEGETATION				VEGETATI ONon SIAM Spectral Categories of WV-2 image≤30		
A12/A1.A4.D1.E2		A12		GREEN JUNE AND OCT			Adjacency to A24/A2.A6.E6			Length/Width ≥5
A12/A1.A4.D2.E1		A12		SINGLE TREES			Adjacency to SAND			
A12/A1.A4.D1.E1		A12		GREEN JUNE AND OCT			Not adjacency to A24/A2.A6.E6			Length/Width <5
A12/A2.A5.E7	A12/A2.A5.E7 + O3.M233.N12-AC (habitat E1.6)	A12		HIGH TEXTURED VEGETATION+ merge+	SIAM on WV-2 fRatioCano pyChloroph		Adjacency to A11/A1.A7.A9.W8 (core) or to A11/A1.A7.A9.W8			Border Index>10



D5.2 VHR land cover maps

				SINGLE TREES+ GREEN JUNE AND NOT OCT	ylContent≤ 2.9		(context)				
	A12/A2.A5.E7 + O3.M233.N3.N12-AR (habitat 1210)		Core	HIGH TEXTURED VEGETATION+ merge+ SINGLE TREES+ GREEN JUNE AND NOT OCT			Adjacency to B28/A1				Length/Width ≥2
A12/A2.A6.E6		A12		HIGH TEXTURED VEGETATION+ merge+ SINGLE TREES+ GREEN JUNE AND NOT OCT			Adjacency to A12/A2.A5.E7 + O3.M233.N3.N12-AR (habitat 1210)(core) or to A12/A2.A5.E7 + O3.M233.N3.N12-AR (habitat 1210)(context)				Length/Width ≥2
A24/A1.A4.D3		A24		SIAM VEGETATION (from 1 to 30)	SIAM QB fRatioWater Index≥1 SIAM WV-2 fRatioWater Index≥1		Adjacency to A24/A2.A5.E6 or to A24/A2.A6.E6				
A24/A2.A6.E6		A24	Core	AQUATIC VEGETATION			Not adjacency to B28/A1				
A11/A1.A7.A9.W8		A11	Core	HIGH TEXTURED VEGETATION+ merge+ SINGLE TREES		N° overlapping with Cadastral only cultivated map>0	Not adjacency to INTERNAL WATER and to B28/A1 and to WET SOIL	Distance to SINGLE TREESs ≥4 and ≤8pxl			Area≤400pxl
			Vegetated context	HIGH TEXTURED			Adjacency to A11/A1.A7.A9.W8			Green Band QB Entropy	Border Index≤3

D5.2 VHR land cover maps

				VEGETATION+ merge			(core)			(occurrence measure) ≤1.2	
A11/A1.A8.A9.W7		A11		HIGH TEXTURED VEGETATION+ merge						Green Band QB Entropy (occurrence measure)<1 .2	Border Index≥30
A11/A3.A5		A11		HIGH TEXTURED VEGETATION+ merge			Adjacency to SIAM BARE SOILS OR BUILT- UP and to (A24/A2.A5.E7+R1.O3. M233 (habitat 3170) or to A12/A2.A5.E7+O3.M23 3MN12-AC (habitat E1.6))		VEGETATI ONon SIAM Spectral Categories of WV-2 image≥31		

F1.1.2.2 Hierarchy of Processing Levels

For *Le Cesine* site, only three strata are provided in the SIAM™ output preliminary map: a) *vegetation*; b) *water or shadow*, c) *soils or built-up*. (See Tables F1.1)

Starting from the output SIAM™ strata in Figure F.1.6, the processing hierarchy adopted in eCognition for the second EODaM classification stage is illustrated here by adopting a different colour for each processing level. Each specific hierarchical processing level starts only once all the classes of previous level in the hierarchy have been extracted for all the strata. Table F1.3 illustrates the colour used whilst Table F1.4 reports the acronyms used in Figures F1.7 a) and b), with these describing the processing levels. An overview of the eCognition operators used in the classification process are reported at the end of this section.

Table F1.3.

1 <sup>st</sup> Level
Merge
2 <sup>nd</sup> Level
3 <sup>rd</sup> Level
Merge
4 <sup>th</sup> Level
5 <sup>th</sup> Level
6 <sup>th</sup> Level
7 <sup>th</sup> Level
8 <sup>th</sup> Level
9 <sup>th</sup> Level

Table F1.4. Table of Acronyms

SC	Quickbird SIAM™ Spectral Categories
LW	Length/Width Ecognition Feature
Ad	Adjacent to
NAd	Not Adjacent to
As	Asymmetry Ecognition Feature
C	Compactness Ecognition Feature
Eg	ENVI 1 <sup>st</sup> order Entropy (for Green Band)
NO to CadCul	Number of Overlapping with Cultivated Layer of Cadastral map
WI_qb	SIAM™ fRatioWaterIndex for Quickbird Image
Dist	Distance
Rd	Roundness Ecognition Feature
BI	Border Index Ecognition Feature
Wv2_SC	Worldview-2 SIAM™ Spectral Categories
WI_wv2	SIAM™ fRatioWaterIndex for Worldview-2 Image
Ch_wv2	SIAM™ fRatioCanopyChlorophyll for Worldview-2 Image

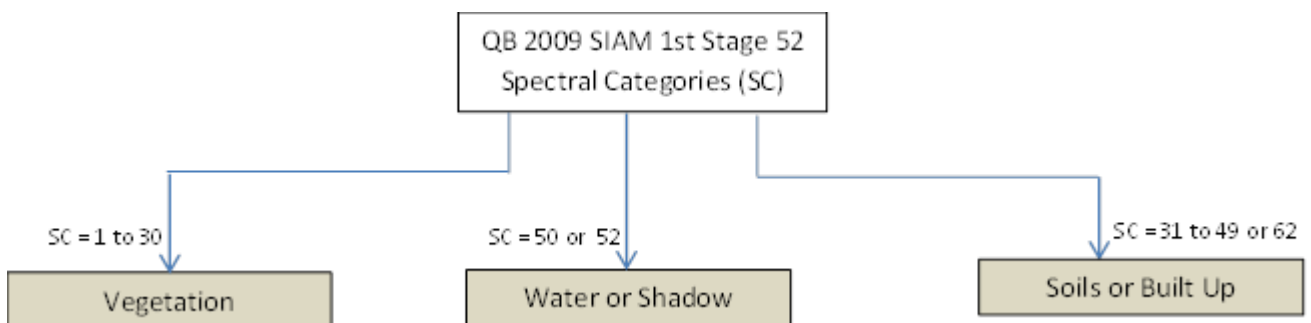

Figure F1.6 SIAM™ output strata

## D5.2 VHR land cover maps

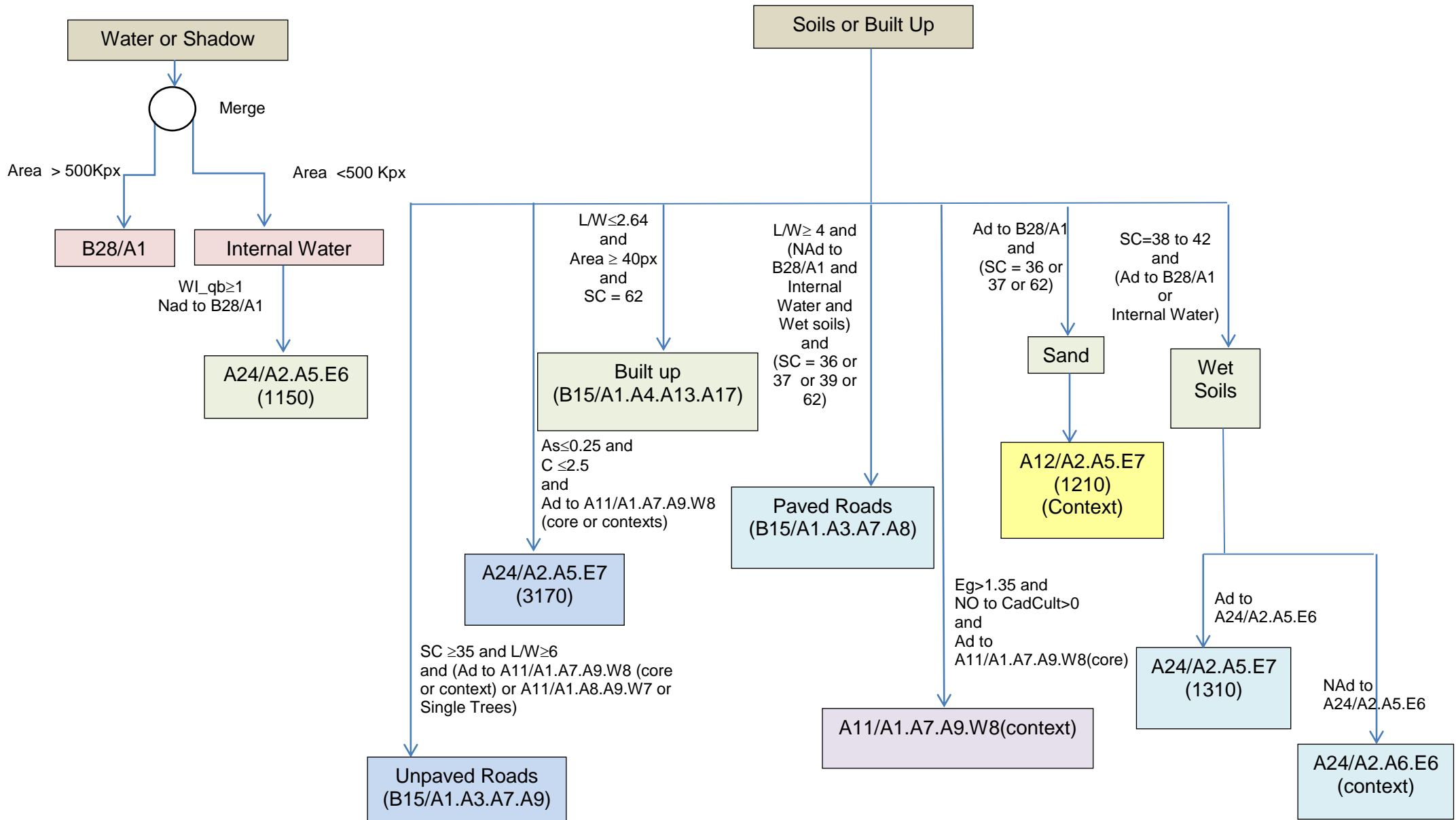

Figure F1.7 a) 2<sup>nd</sup> stage hierarchical processing chain for Water or Shadow and Bare Soils or Built-up SIAM™ strata. At 2.4 m spatial resolution shadow is not detectable.

D5.2 VHR land cover maps

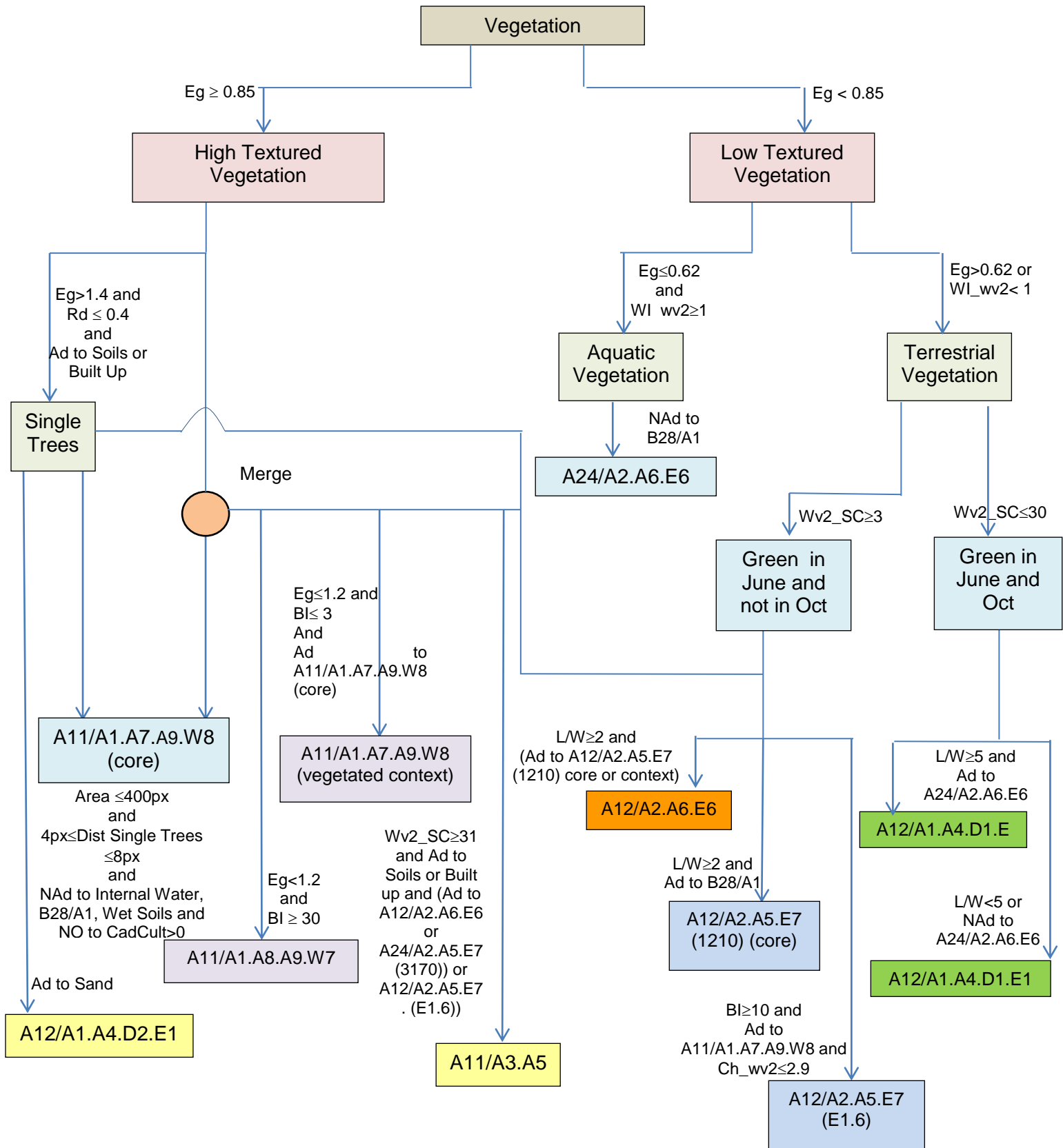

Figure F1.7 b) 2<sup>nd</sup> stage hierarchical processing chain for Vegetation SIAM™ strata.

### Features considered for classification

The following provides a brief description of eCognition features considered in the classification.

1) *Border Index*: The Border Index feature describes how jagged an image object is; the more jagged, the higher its border index. This feature uses a rectangular approximation; the smallest rectangle enclosing the image object is created and the border index is calculated as the ratio between the border lengths of the image object and the smallest enclosing rectangle.

Feature Value Range =  $[1;\infty]$  ; 1 = ideal.

2) *Length/Width*: There are two methods to approximate this:

1. The ratio of length to width is identical to the ratio of the eigenvalues of the covariance matrix;

2. The ratio of length to width can also be approximated using a bounding box:

Both calculations are compared; the smaller of both results is returned as the feature value.

3) *Asymmetry*: The Asymmetry feature describes the relative length of an image object, compared to a regular polygon. An ellipse is approximated around a given image object, which can be expressed by the ratio of the lengths of its minor and the major axes. The feature value increases with this asymmetry.

4) *Compactness*: The Compactness feature describes how compact an image object is. It is similar to Border Index, but is based on area. However, the more compact an image object is, the smaller its border appears. The compactness of an image object is the product of the length and the width, divided by the number of pixels.

Feature Value Range =  $[0;\infty]$  ; 1 = ideal.

5) *Roundness*: The Roundness feature describes how similar an image object is to an ellipse. It is calculated by the difference of the enclosing ellipse and the enclosed ellipse. The radius of the largest enclosed ellipse is subtracted from the radius of the smallest enclosing ellipse.

Feature Value Range =  $[0;\infty]$  ; 0 = ideal.

### Future processings

Next processing should focus on:

- Use of multisensory information considering the contribute of the complementary Worldview-2 bands not considered by SIAMTM as in [Tarantino, 2010 “Tarantino C., Adamo M., Pasquariello G., Lovergine F., Blonda P., Tomaselli V. “8-Band Image Data Processing of theWorldview-2 Satellite in a Wide Area of Applications”, in press by Earth Observation Book, ISBN 978-953-307-655-3, approved on September 2010]
- New indexes, such as a water index based on the ratio between the two NIR bands of Worldview-2 (see D5.2) will be considered
- The improvement in the use of the textural feature (entropy on the green band) to detect different plant height levels: other multiscale or 2nd order textural measures could be tested;
- The design and implementation of additional specific features to detect oriented texture, such as the the variogram as reported in [Amoruso N., Baraldi A., Tarantino C., Blonda P. “Spectral rules and geostatistics features for characterizing olive groves in Quickbird images”, proceedings (ISBN 978-1-4244-3395-7/09) by IGARSS 2009, IV: 228-231] for identifying agricultural areas in absence of updated an cadastral map.
- Use of pan-sharpened data, i.e. higher resolution.

## F1.2 Two-stage classifications to LCCS Level 3 (i.e. Dichotomous stage) with a 1<sup>st</sup> stage based on e-Cognition spectral segmentation.

### F1.2.1 General approach

Within eCognition, a spectral segmentation of the imagery was undertaken by first performing a chessboard segmentation (to one pixel) followed by a spectral difference segmentation based primarily on the visible red or green and near infrared wavebands depending on the month of image acquisition. Where multiple scenes are acquired, the segmentation needs to be based on all input datasets but using these same two channels. Optimal channels for segmentation are being investigated and will be reported in D5.4. Following segmentation, a progressive classification of the imagery based on LCCS levels 1 to 3 was performed. Initially, vegetated and non-vegetated surfaces were differentiated followed by terrestrial and aquatic. Cultivated/managed and not cultivated/managed were then separated followed by artificial and natural bare areas, including water. These independent classifications were then combined following consideration of the optimal pathway through use of semantic nets. An overview of these procedures is outlined below.

**Vegetated versus non-vegetated:** For all sites, the classification of vegetation and non-vegetation required identification of areas of photosynthetic vegetation (PV), non-photosynthetic vegetation (NPV) and submerged aquatic vegetation (Figure F1.8). For mapping PV, the NDVI was considered sufficiently robust, although threshold values varying between sites (Table F1.5) largely because of seasonal differences in vegetation phenology and the timing of the remote sensing data acquisition. For mapping NPV, the PSRI was used where Worldview II data were available although was unable to be calculated using the Quickbird imagery because of the lack of a red edge channel. In the case of Quickbird imagery, the use of the NPV endmember fraction derived through linear spectral unmixing provided an alternative. In Wales, the PSRI provided a good indication of the extent of *P. australis*, *M. caerulea* and *Pteridium aquilinum* (bracken), all of which are largely non photosynthetic from the autumn through to late spring, as well as the dry grasslands and herbaceous layers occurring within olive groves at Le Cesine. SAV was mainly present in the summer Quickbird image acquired for Le Cesine and was identified as vegetation (with a high green reflectance) within areas identified as water (based on the WBI). The areas of PV, NPV and SAV were combined to define the extent of the LCCS category A1 (vegetated). All remaining categories were associated with non-vegetation (see Figure F1.10).

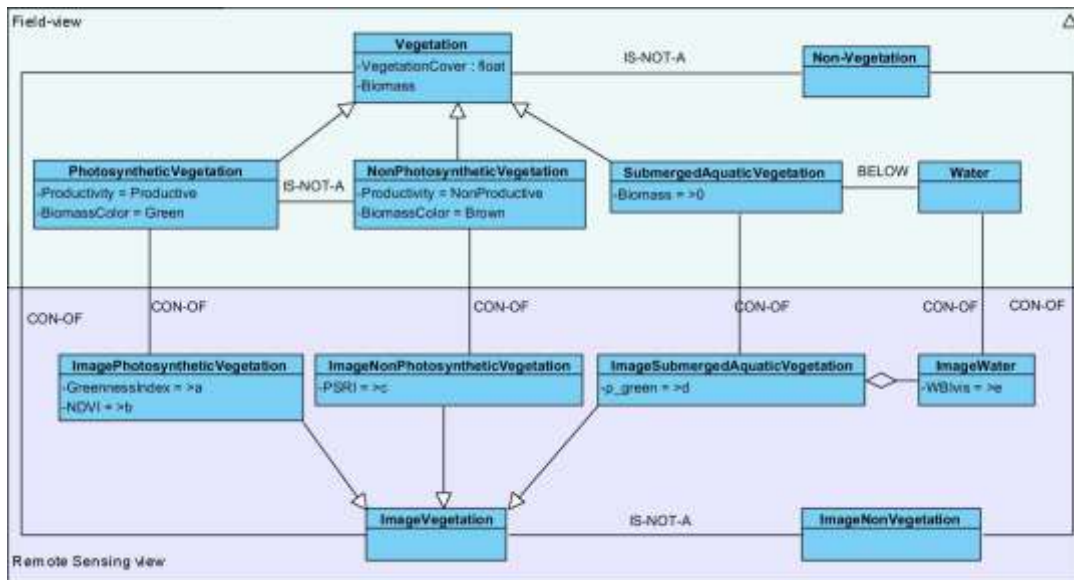

Figure F1.8. Semantic net relating to the discrimination of vegetated and non-vegetated surfaces. Note that the values a, b, c and d are listed in Table 7.1.

**Terrestrial versus aquatic:** For all sites, the extent of open water was mapped successfully using the WBI, although some confusion with shadow was evident, and assigned to the aquatic or regularly flooded class together with areas of SAV that had been mapped previously. The main difficulty was with the mapping of aquatic vegetation where the water surface was not exposed (e.g., active raised bogs and tall grasslands, such as those dominated by *P. australis*) and separate classification of these was necessary using more specific rules. All areas not associated with aquatic land covers were assigned to the terrestrial class. The semantic nets for differentiating terrestrial and aquatic surfaces are given in Figure F1.9.

The intersection of layers representing vegetation and non-vegetation and terrestrial and aquatic, examples of which are given for Le Cesine in Figure F1.7 resulted in the generation of the LCCS Level 2 maps for all sites. The rules applied for the generation of these layers were consistent between sites with the exception of some site-specific aquatic land covers. The approach also aligned with that required for the development of semantic nets.

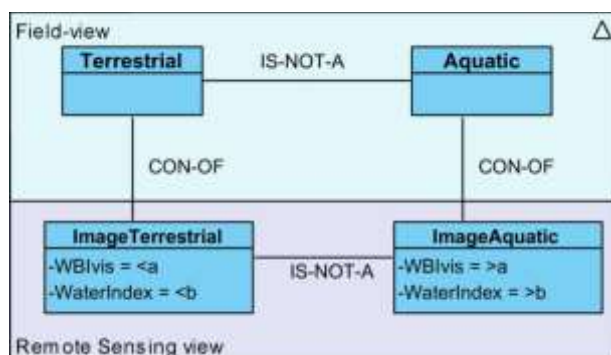
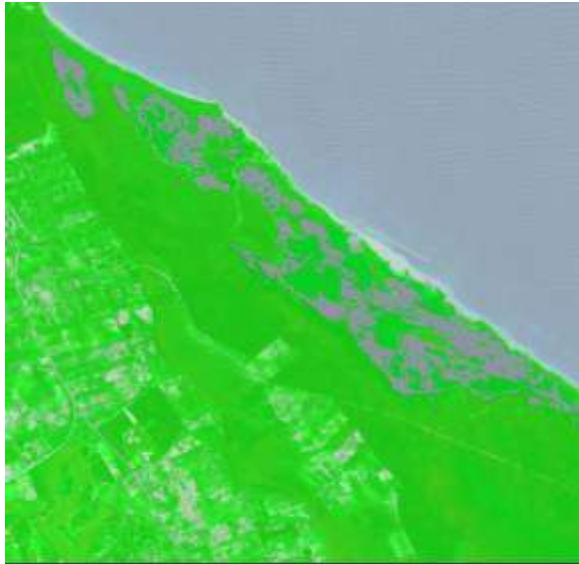

Figure F1.9. Semantic net for terrestrial versus aquatic categories.



a)



b)



Figure F1.10. Classification of a section of Le Cesine into a) vegetated and non-vegetated and b) terrestrial and aquatic surfaces.

D5.2 VHR land cover maps

Table F1.5 Rules used in the classification of LCCS categories (Level 1 to 3)

Broad class	Sub-class	Le Cesine	Cors Fochno	Cors Caron	Netherlands
Vegetation	PV	$NDVI \geq a$	$NDVI \geq a$	$NDVI \geq a$	$NDVI \geq a$
	NPV	$PSRI \geq b$	$PSRI \geq b$	$PSRI \geq b$	$PSRI \geq b, < c$
	SAV	$\rho_{green}^1 > d$	$\rho_{green} > d$	$\rho_{green} > d$	Green > (not used)
Not vegetation		Opposite of vegetated			
Aquatic	Open water	$WBI \geq 1$	$WBI \geq 1$	$WBI \geq 1$	$WBI \geq$ (not used)
	SAV	As above	As above	As above	As above
	Closed AV	Habitat-specific	Habitat-specific	Habitat-specific	Habitat-specific
Terrestrial		Opposite of aquatic			
Cultivated/ managed	Forest plantations	Forestry layer	Forestry layer	Forestry layer	Forestry layer
	Crops	Cadastral	Cadastral	Cadastral	Cadastral
	Orchards	2 level Cadastral <sup>2</sup>	2 level Cadastral	2 level Cadastral	2 level Cadastral
Not-cultivated	Unmanaged	Opposite of cultivated			
Artificial	Water	Geometry &	Geometry &	Geometry &	Geometry &
	Not-vegetated	Infrastructure <sup>3</sup>	Infrastructure	Infrastructure	Infrastructure
Not artificial		Non-vegetated and opposite of artificial			

<sup>1</sup>Following identification of open water using the WBI; <sup>2</sup>Establishes presence of trees in a hierarchical sub-level; <sup>3</sup>Including artificial waterbodies or reservoirs. <sup>2</sup>Values were variable between sites because of the different dates of image acquisition with *a* typically ranging from 0.15 to 0.2, *b* and *c* approximating 0.1 and 0.13 respectively and *d* approximating 20 %.

**Cultivated versus non-cultivated:** The extent of cultivation was defined primarily with reference to cadastral layers, with segments corresponding closely with the distribution of agricultural land observed within the VHR imagery. In Italy, the classification of agricultural land without the use of cadastral information was difficult because of the low contrast between adjacent fields, particularly where olive groves occurred. For Wales and, to a lesser extent, the Netherlands, maps of cultivated land generated from the images themselves corresponded closely with those defined using the LPIS Cadastral layer, although several fields were omitted or inappropriately merged. Attributes associated with the cadastral layers (e.g., crop type or land use) were useful in refining the mapping of cultivated areas. Where cadastral information was available, areas supporting tree crops were distinguished by identifying individual or groups of trees in a finer segmentation and then quantifying the number or relative area within larger objects defined using a coarser segmentation (e.g., equivalent to individual fields). An example of the mapping is given in Figure F1.11. The semantic nets developed for the classification of cultivated versus non-cultivated land is given in Figure F1.12.

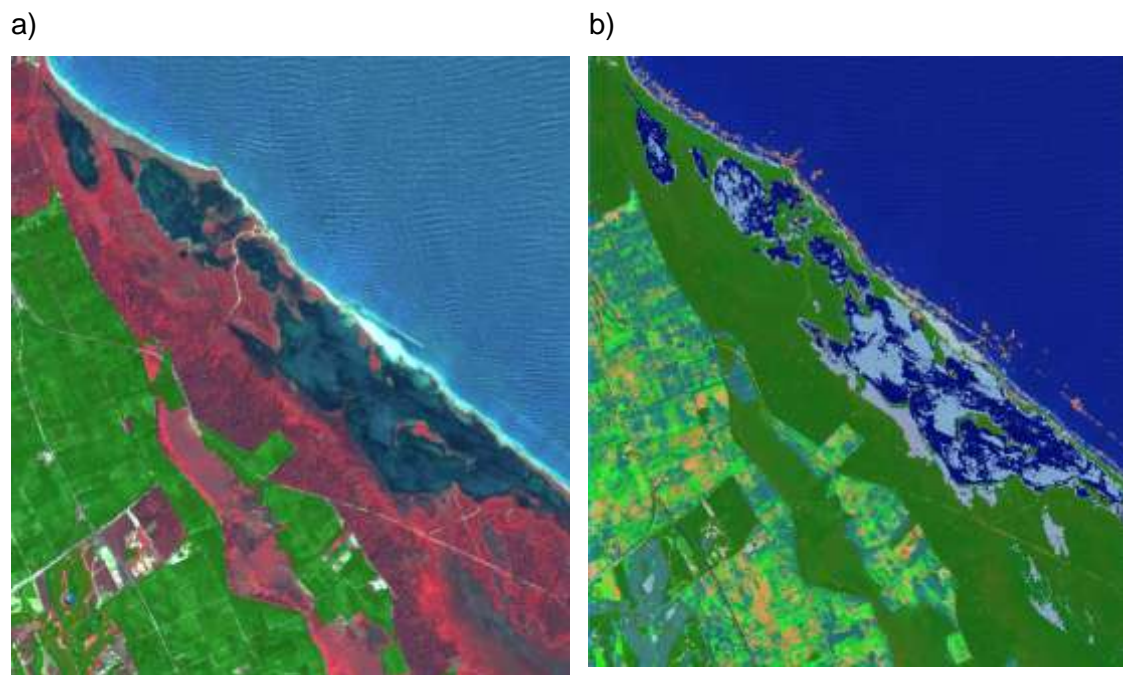

Figure F1.11. a) Area of cultivated land (green) at Le Cesine, identified through reference to existing cadastral information and b) sub-level classification of foreground olive trees (blue-grey) and background bare ground (orange) and graminoid/herbaceous vegetation (bright green).

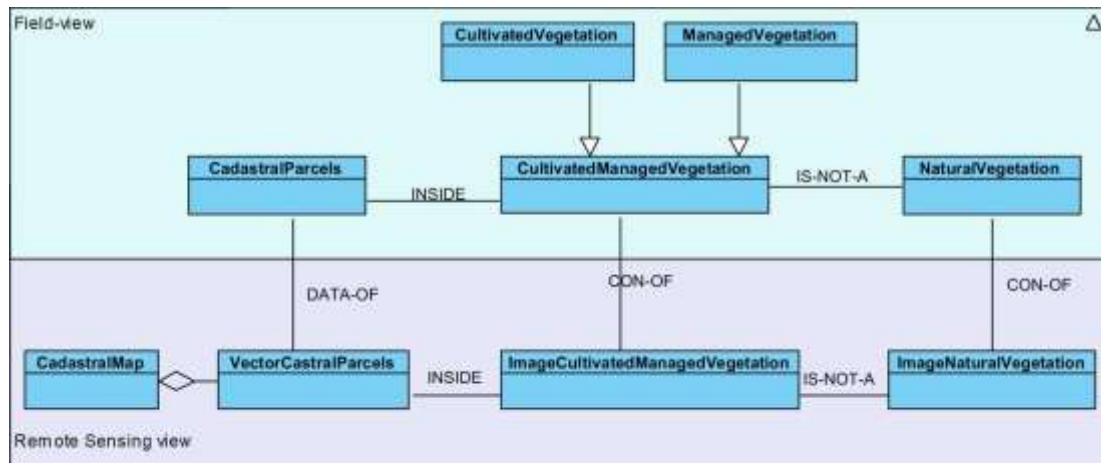

Figure F1.12. Semantic nets for cultivated versus non-cultivated

Whilst ancillary data relating to the extent of forestry plantations were available, the preference was to identify such areas from the image data themselves, although success was variable. Within Wales, no areas of natural coniferous forest occur and hence any mapped forest can be associated with a commercial plantation. However, in Italy and the Netherlands, some areas of natural coniferous forest (e.g., dominated by Scots Pine or *Pinus sylvestris*) occurred. Whilst not achieved in the preliminary maps, differentiation based on the organization of planting (e.g., in rows) would facilitate classification from the image data themselves.

**Artificial versus non-artificial:** The majority of artificial surfaces are non-vegetated and either consist of infrastructure (e.g., buildings, roads, railways etc.) or water (e.g., reservoirs, canals). As infrastructure is complex, both spectrally and geometrically, the preliminary maps were generated using available thematic layers (e.g., the OS Mastermap). However, by assuming that all objects with an NDVI less than the values used for identifying vegetation were candidates for this category and using spectral information and feature extraction (e.g., based on size and shape), maps of urban infrastructure were generated. The main limitation of these was that they were not of the same quality as the vector maps and not all components of the urban matrix could be extracted. Those areas of non-vegetation (excluding water bodies) were assigned to the bare ground category.

For identifying artificial water bodies, reference was made to existing mapping where available (e.g., for Wales). However, many artificial waterbodies were associated with a dam wall and infrastructure (e.g., roads, control towers). Hence, some automation in the classification of artificial waterbodies was achieved. All remaining water bodies were assumed to be natural. The LCCS Level 3 classification was obtained through intersection of the Level 2 classification to generate the eight categories required and examples of these for Le Cesine, Cors Caron and the Netherlands are provided in Figure F1.13.

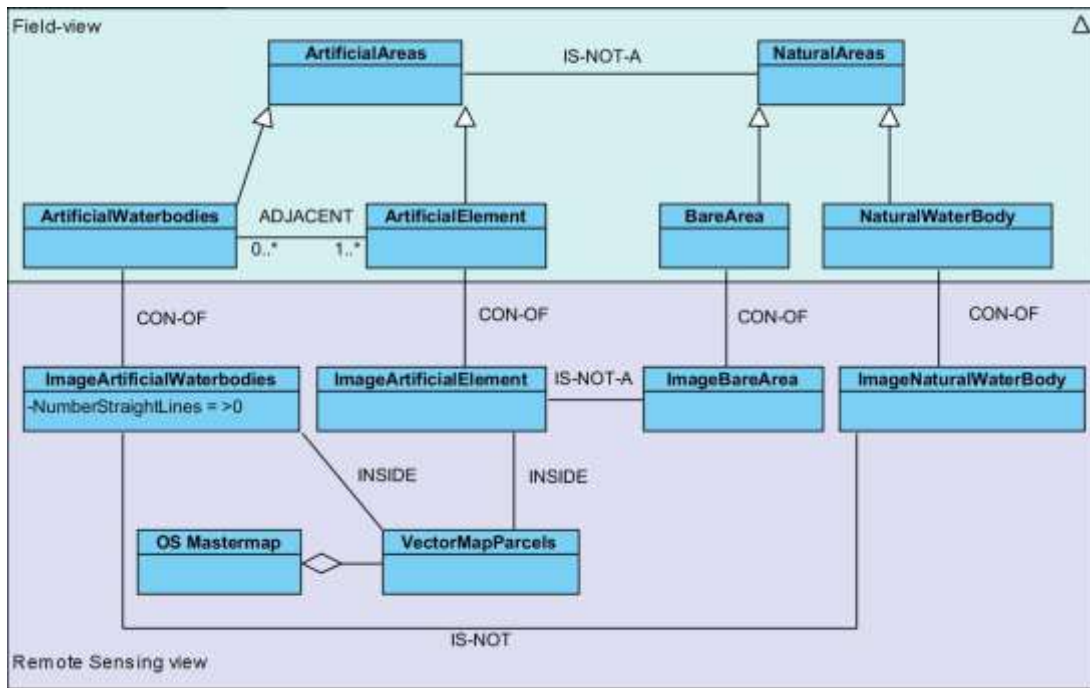

Figure F1.13). Semantic net describing artificial versus non-artificial surfaces (natural).

### F1.2.2 Site classifications to Level 3

For each of the sites (Le Cesine, the Netherland, Cors Caron and Cors Fochno), the classifications to Level 3 were generated using a rule-based approach in eCognition. With the exception of Le Cesine, for which both Quickbird and Worldview II images were available, the classifications were undertaken using single-date Worldview images. In all cases, the classification of the cultivated and urban environments was necessarily generated with reference to existing cadastral layers.

For Le Cesine (Figure F1.14a), the classification provided a good representation of the categories occurring. Some modification were necessary in that extensive areas of submerged aquatic vegetation occurred which was in contrast to the other sites. For the Netherlands sites (Figure F1.14b), patchy cloud cover and associated cloud shadows occurred in the imagery and these were removed initially through masking but subsequently using region growing rules within eCognition, commencing with a coarse segmentation of the image and the progressively decreasing the object size to 1 pixel and visible/near infrared thresholds to capture the margins of clouds and cloud shadows.

For Cors Caron (Figure F1.14c) and Cors Fochno (Figure F1.14d), the main modification was that the active raised bog and grasslands dominated by *Phragmites* species required classification for inclusion into the aquatic category (A24). Artificial waterbodies, including those associated with restoration efforts for the peat domes, were mapped as those that were observed within the imagery but had not been previously mapped in existing water layers.

D5.2 VHR land cover maps

a)

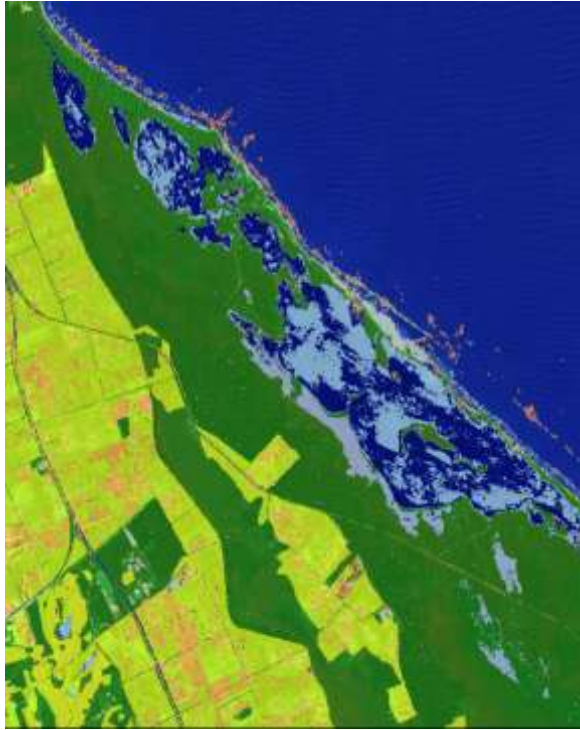

b)

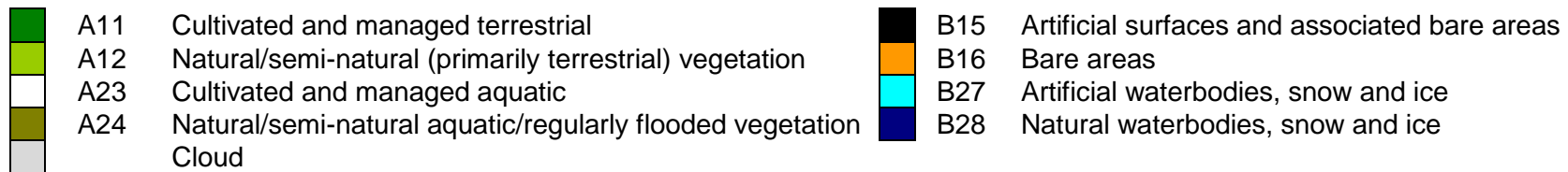
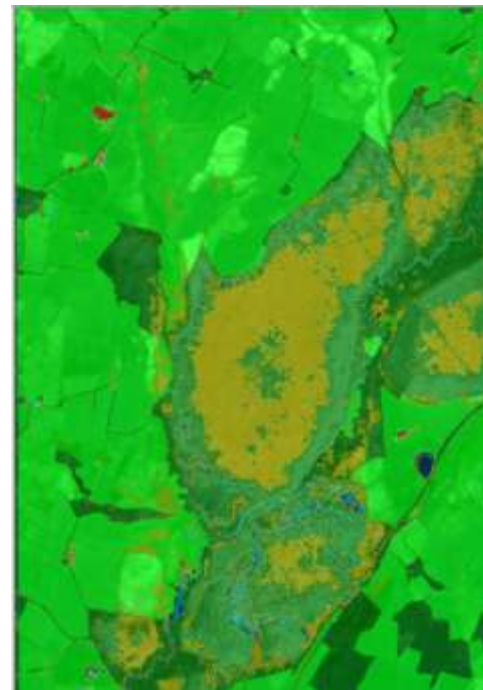

Figure F1.14 Maps of LCCS categories (up to Level 3) for a) Le Cesine, b) Cors Caron and c) the Netherlands.

c)



d)



<table border="0"> <tr><td style="width: 15px; height: 15px; background-color: #008000;"></td><td>A11</td></tr> <tr><td style="width: 15px; height: 15px; background-color: #90EE90;"></td><td>A12</td></tr> <tr><td style="width: 15px; height: 15px; background-color: #FFFFFF;"></td><td>A23</td></tr> <tr><td style="width: 15px; height: 15px; background-color: #808000;"></td><td>A24</td></tr> </table>		A11		A12		A23		A24	<p>A11 Cultivated and managed terrestrial  A12 Natural/semi-natural (primarily terrestrial) vegetation  A23 Cultivated and managed aquatic  A24 Natural/semi-natural aquatic/regularly flooded vegetation</p>
	A11								
	A12								
	A23								
	A24								

<table border="0"> <tr><td style="width: 15px; height: 15px; background-color: #000000;"></td><td>B15</td></tr> <tr><td style="width: 15px; height: 15px; background-color: #FFA500;"></td><td>B16</td></tr> <tr><td style="width: 15px; height: 15px; background-color: #00FFFF;"></td><td>B27</td></tr> <tr><td style="width: 15px; height: 15px; background-color: #000080;"></td><td>B28</td></tr> </table>		B15		B16		B27		B28	<p>B15 Artificial surfaces and associated bare areas  B16 Bare areas  B27 Artificial waterbodies, snow and ice  B28 Natural waterbodies, snow and ice</p>
	B15								
	B16								
	B27								
	B28								

Figure F1.14. Maps of LCCS categories (up to Level 3) for c) Cors Fochno and d) Cors Caron

### F1.2.3 Comparison of approach implemented with eCognition and SIAM.

The same approach outlined above was also applied to the SIAM spectral categories obtained from just the Worldview II image and the following provides a comparison between the two approaches. In determining Levels 1-2, no ancillary data were used. However, for Level 3, field boundaries were necessarily included but no difference in the outcome of the classification using both techniques occurs.

For the mapping of vegetation and non-vegetation, a similar result was obtained (Figure F1.15), although areas of non-photosynthetic vegetation were less able to be defined using SIAM. Using eCognition, such areas were identified using the PSRI noting that this is only available for the Worldview data. Where only four band visible and near infrared imagery are available, the use of the non-photosynthetic endmember fraction may provide options for identifying this cover type within the imagery.

a)



b)

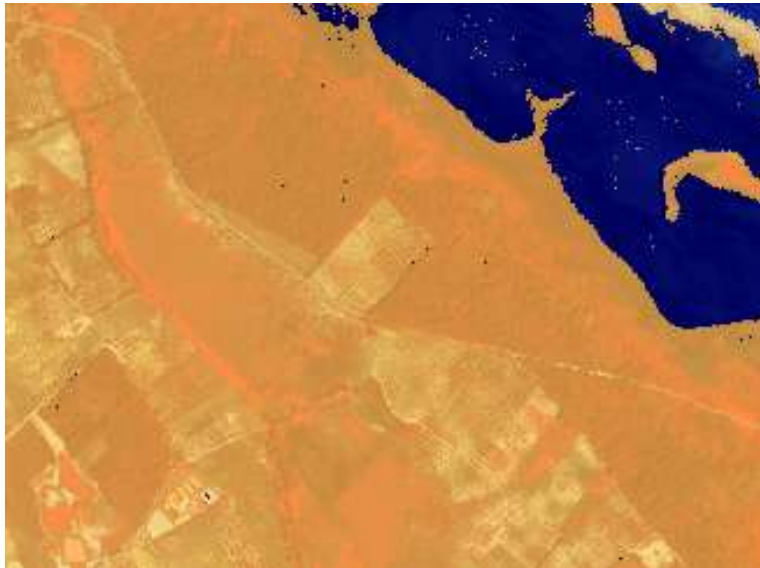

Figure F1.15. Maps of vegetation (green) and non vegetation (grey) generated using a) SIAM spectral categories and b) spectral indices. Both classifications were generated within eCognition

In the classification of aquatic versus terrestrial vegetation, areas of open water were equally well defined using the WBI and the SIAM spectral categories associated with this class. However, using the spectral information and indices, areas of aquatic vegetation overlaying a water or moist surface could be identified and incorporated into the classification (Figure F1.16). Such integration could not be performed so well using SIAM because of confusion between aquatic vegetation and shadow within the forest areas. The combination of these categories to classify to LCCS Level 2 is shown in Figure F1.17 based on SIAM and the use of spectral reflectance data and indices. The comparison highlights the benefits of using the latter for refining classification of specific land covers. The classification to LCCS Level 3 follows the same procedures and integrates ancillary information. Therefore, no difference in the extent of cultivated/managed and artificial/natural water bodies and bare surfaces occurs.



a)



b)

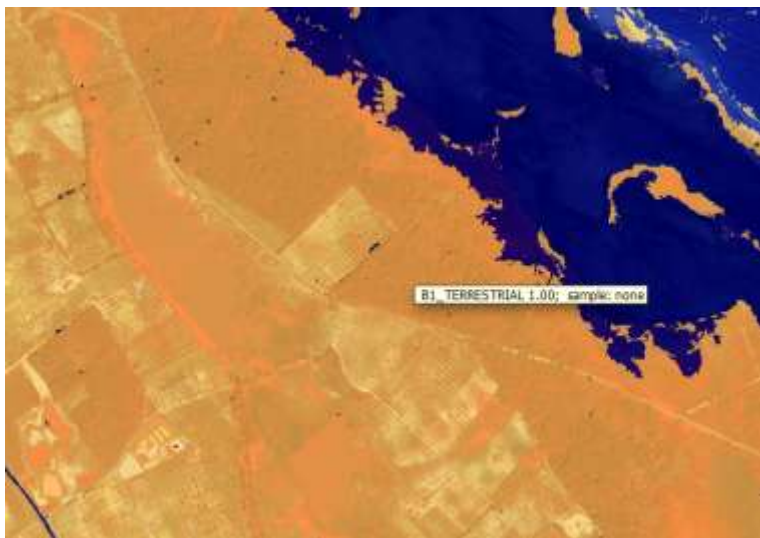

Figure F1.16. Maps of terrestrial (orange) and aquatic (blue) surfaces mapped using a) SIAM and b) spectral indices. Both classifications were generated within eCognition.

The segmentation of the image is critical to the subsequent identification of the land cover categories. However, the use of the chessboard followed by the spectral difference segmentation provided a clear representation of patterns in the landscape. For segmentation, only the NDVI was used but additional data layers could be incorporated. The comparison establishes that the segmentation and classification generated using eCognition is comparable to that which can be achieved using SIAM for the case study considered.

## D5.2 VHR land cover maps

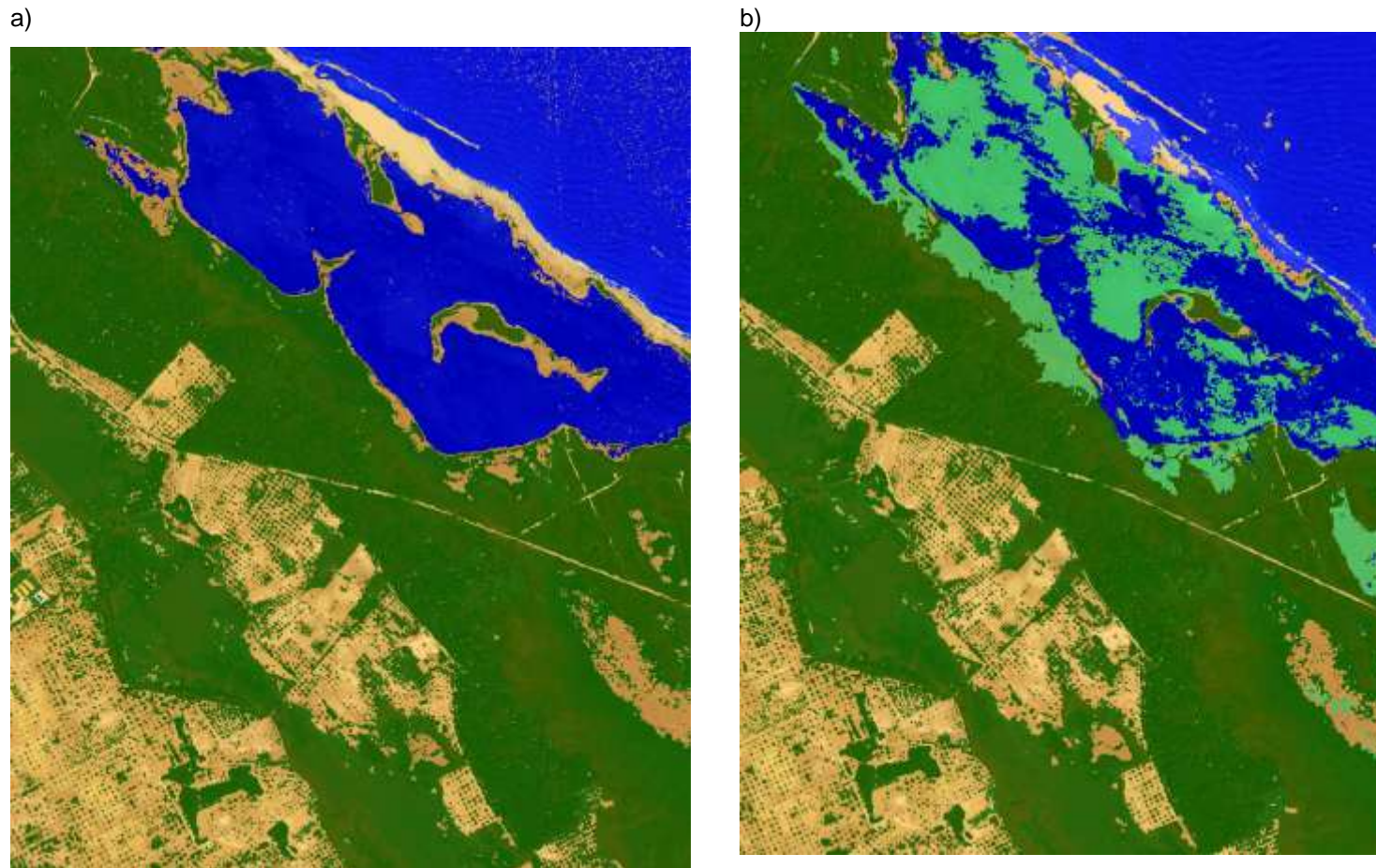

Figure F1.17. Maps of land cover to LCCS Level 2 generated using a) SIAM and b) spectral indices. Both classifications were generated within eCognition.

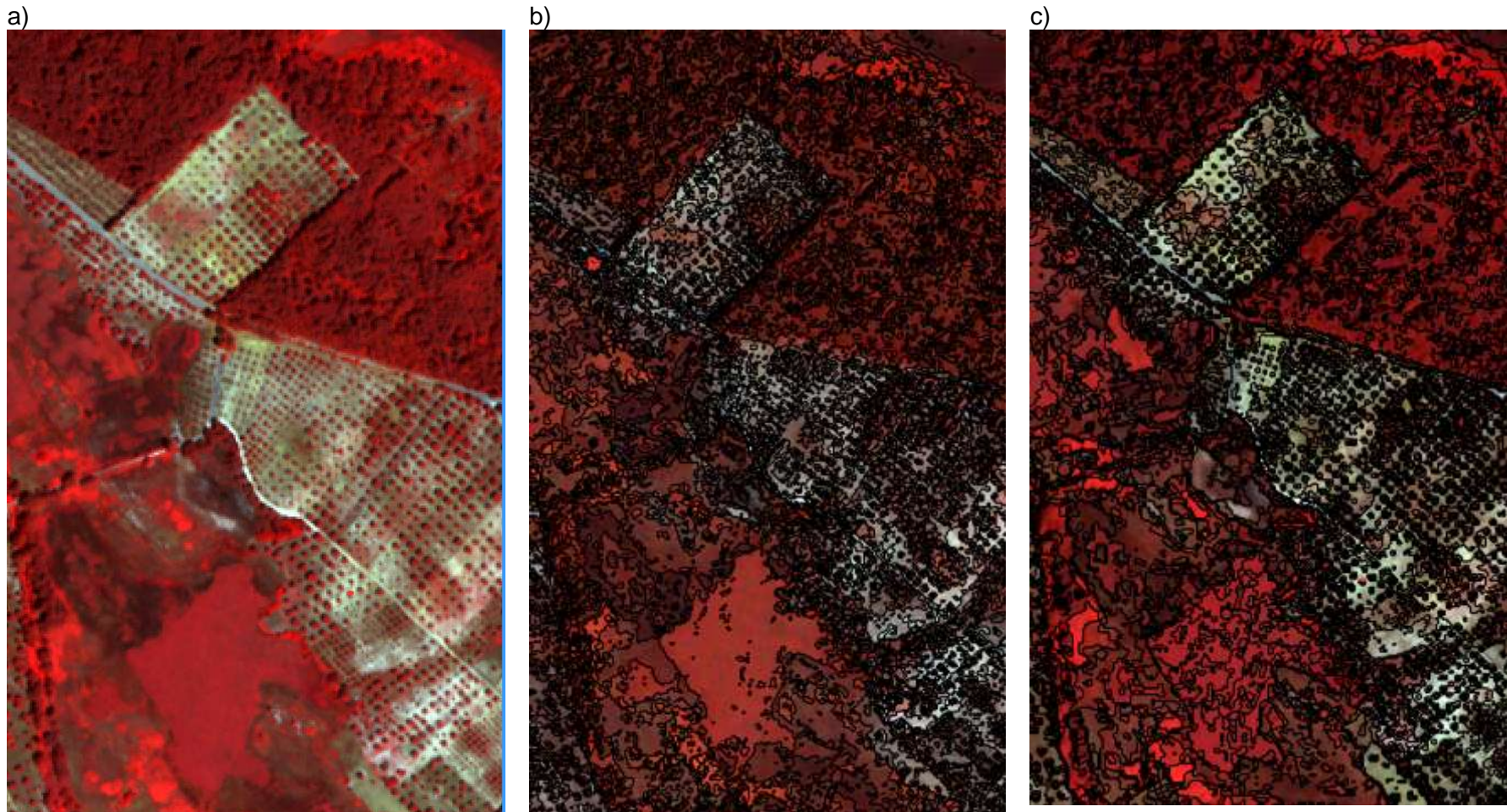

Figure F1.18. a) Original subset of Worldview II image of Le Cesine, b) Segmentation based on SIAM spectral categories and c) Segmentation based on a chessboard followed by a spectral difference segmentation in eCognition.

### F1.3 Classifications of life forms, surface aspect and physical status

For each of the sites, consistent classification of land covers and associated habitats presented a greater challenge because of the diversity occurring and the uniqueness of many of those encountered in each (e.g., active bog in Wales, marshes in Italy and inland sand dunes in the Netherlands). Differences in the approach to classification were therefore necessary because of the different types and dates of the available image data. However, in each case, focus was on providing an approach that could be applied consistently to imagery regardless of their modality and acquisition times.

For the classification of the LCCS subcategories, the rules inherited from Levels 1 to 3 were first applied. Then, within each of the categories at Level 3, more specific semantic nets were developed. When describing these sub-categories, consideration is given to life forms (for natural and semi-natural vegetation; i.e., woody vegetation and herbaceous), but also surface aspect (bare areas) and physical status and persistence (waterbodies, snow and ice) (Figure F1.19).

a)



b)

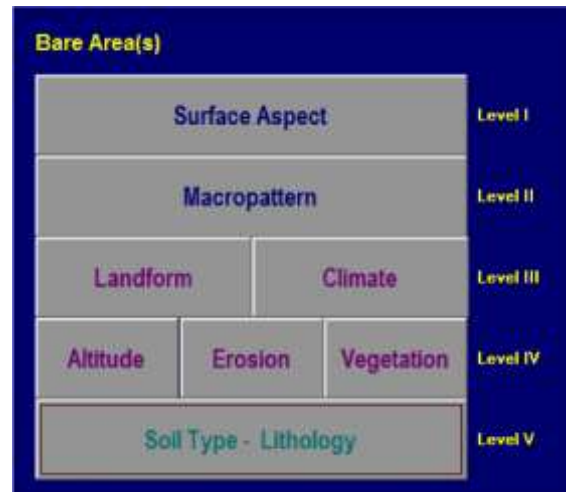

c)



Figure F1.19). Further levels within the LCCS in the classification of vegetated and non-vegetated surfaces.

## D5.2 VHR land cover maps

The LCCS sub-categories relate also to the five GHC super-categories, which are themselves described on the basis of life form (height, cover, leaf type and phenology of vegetated categories) as well as surface aspect (e.g., sand, earth) and physical status (e.g., water depth, salinity) and persistence (e.g., permanent, ephemeral):

- a) Vegetated forests and shrublands
- b) Vegetated herbaceous
- c) Cultivated and managed areas (including urban areas with vegetation)
- d) Urban
- e) Sparsely vegetation, including water bodies

On this basis, templates for semantic nets that represented each of these five broad categories were developed and, within these, variables were included which described how, within these, different sub-categories (whether LCCS or GHC) might be classified from a field observers' and remote sensing perspective. In the following sections, the templates are conveyed and the classification of each site is then reviewed in turn, with this based on rule-based approach implemented within eCognition. SIAM spectral categories used in the classification of these 'super categories) are given in the section following. Finally, an overview of the generality of the approach is provided.

### F1.3.1 Classifications based on eCognition spectral segmentation

#### F1.3.1.1 Template development

The template for **vegetated trees and shrubs** (Figure F1.15), which includes forests, woodlands, shrublands and brushlands, considered both the field and the remote sensing components.

The Food and Agricultural Organization (FAO) defines forests (which includes woodland) as: "Land with tree crown cover (or equivalent stocking level) of more than 10 % and area of more than 0.5 ha. The trees should be able to reach a minimum height of 5 m at maturity *in situ*. May consist either of closed forest formations where trees of various storeys and undergrowth cover a high proportion of the ground, or of open forest formations with a continuous vegetation cover in which tree crown cover exceeds 10 percent. Young natural stands and all plantations established for forestry purposes which have yet to reach a crown density of 10 % or tree height of 5 m are included under forest, as are areas normally forming part of the forest area which are temporarily unstocked as a result of human intervention or natural causes but which are expected to revert to forest." The definition includes "forest nurseries and seed orchards that constitute an integral part of the forest; forest roads, cleared tracts, firebreaks and other small open areas within the forest; forest in national parks, nature reserves and other protected areas such as those of special environmental, scientific, historical, cultural or spiritual interest; windbreaks and shelterbelts of trees with an area of more than 0.5 ha and a width of more than 20 m. Rubber wood plantations and cork oak stands are included". Land used predominantly for agricultural purposes is excluded. Shrubland and brushland are defined as "Woody perennial plants, generally of more than 0.5 m and less than 5 m height, and often without a definite stem and crown. "Trees outside of the forest" are excluded"

Whilst the FAO definition is intended to be universal, forest definitions are highly variable internationally and within Europe (Bunce *et al.*, 2011) but all rely on descriptors of height, cover, density, area and/or species composition. In the GHC Handbook, GHCs associated with trees and shrubs within mapping areal elements > 0.04 ha and > 5 m width need to have a canopy cover of more than 30 %, with

## D5.2 VHR land cover maps

shrublands and forests being < 5 m and  $\geq$  5 m respectively. Compared to the FAO description, there is no minimum height as dwarf shrubs are also included as a tree and shrub, with these defined as being < 5 m. Typically, the Above Ground Biomass (AGB) of woody vegetation (which relates to height) is  $> 10 \text{ Mg ha}^{-1}$  (for stands with trees  $> 2 \text{ m}$  and sometimes over  $1000 \text{ Mg ha}^{-1}$ ), highly variable and exceeds that of herbaceous vegetation. As height is not adequate alone for discriminating vegetated trees and shrubs, biome (or phenological) (e.g., deciduous, evergreen) and leaf type (e.g., broad-leaved, needle-leaved) descriptors are also used. In terms of seasonal phenology, most needle-leaved forests and some broad-leaved species (particularly in less temperate environments) retain their leaves throughout the year but others (including the needle-leaved larch (*Larix*) species and broad-leaved species) are deciduous with distinct periods of leaf flush and senescence (i.e., spring and autumn). The crowns of needle-leaved species (e.g., firs and other softwoods) are typically excurrent (i.e., have an undivided main stem), conical in shape and smaller than those of broad-leaved species of equivalent age, particularly as they tend towards maturity. Most broad-leaved species are hardwood and of decurrent form, with several to many lateral branches that compete with the central stem for dominance resulting in a spherical or globose crown. Forests and shrublands can be continuous or fragmented, striped or cellular. They can also form a canopy above soil, water, sand (e.g., in the case of mangroves) or herbaceous vegetation, or these surfaces may appear in between crowns. In BIOSOS, the GHC descriptors relating to vegetated trees and shrubs were adopted, particularly as further discrimination within this category could be achieved using this system, which largely paralleled that of the LCCS. A summary of biophysical characteristics of forests and shrublands, from a field observer's perspective, is given in Table F1.6.

Table F1.6. Values typical for vegetated trees and shrubs and GHC/LCCS definitions (based on template in Figure F1.12)

Type	Area /width	Height	Cover	Leaf Type	Leaf Phenology	Biomass
Forests	$> 0.04\text{ha}$ $> 5 \text{ m}$	$\geq 5 \text{ m}$	$> 30 \%$	Broad-leaved/ Needle-leaved	Deciduous/ Evergreen	$> 10 \text{ Mg ha}^{-1}$
Shrubs	$> 0.04\text{ha}$ $> 5 \text{ m}$	$< 5 \text{ m}$	Variable	Broad-leaved/ Needle-leaved Aphyllous <sup>1</sup>	Deciduous/ Evergreen	$< 10 \text{ Mg ha}^{-1}$

<sup>1</sup>e.g., Gorse (*Ulex* species)

From remote sensing data, the height and cover of forests and shrublands can be derived directly from LiDAR data or through empirical relationships established with optical remote sensing data or derived measures (e.g., texture). LiDAR and also low frequency (L and P-band) Synthetic Aperture Radar (SAR) can also be used to retrieve the height and AGB of woody vegetation (e.g., Luckman et al, 1997, Saatchi et al., 2007; Lucas et al., 2011), although relationships established with optical data have primarily been the result of indirect links between canopy attributes (e.g., degree of shadowing) and AGB (e.g., Steininger, 2000). To differentiate between evergreen and deciduous needle-leaved and broad-leaved species, multi-temporal measures of leaf presence and productivity (e.g., the NDVI) are required although some differentiation can be achieved through spectral classification of single data imagery. Within VHR optical and LiDAR data, differences between forest and shrubland types can be achieved by considering the area and 2D/3D shape of delineated tree crowns.

## D5.2 VHR land cover maps

The semantic net defined for the super-category of forests and shrublands is given in Figure F1.20 from a field observer's point of view and reflects the information in Table F1.7 (shaded green). A similar net from the remote sensing point of view is also given (shaded purple), with Table F1.8 indicating the main remote sensing descriptors used. Typical values for Le Cesine, Cors Caron, Cors Fochno and the Netherlands in terms of remote sensing data are given in a later section.

Table F1.7 a) and b). Values typical for vegetated trees and shrubs, based on the semantic net template for this category

a)

Type	Height (m)	LeafPhenology	LeafType	Biomass
Broad-leaved	5-30 m	Seasonal variation/ No variation	Deciduous/ Broad-leaved	> 10 Mg ha <sup>-1</sup>
Needle-leaved	5-30 m	No seasonal variation	Needle-leaved	> 10 Mg ha <sup>-1</sup>
Shrubland	0.05-5 m	Seasonal variation/ No variation	Deciduous/ Broad-leaved/ Aphyllous	< 10 Mg ha <sup>-1</sup>

b)

Type	Cover	Shape	Spatial distribution	Biomass
Broad-leaved	Closed	Decurrent	Continuous Fragmented Striped Fragmented Cellular Park-like	> 10 Mg ha <sup>-1</sup>
Needle-leaved	Closed	Excurent	Continuous Fragmented Striped Fragmented Cellular Park-like	> 10 Mg ha <sup>-1</sup>
Shrubland	Closed > open	Decurrent	Continuous Fragmented Striped Fragmented Cellular	< 10 Mg ha <sup>-1</sup>

Table F1.8 Key attributes of vegetated trees and shrubs and the key remote sensing data and products needed for their description and mapping.

	Needle-leaved		Broad-leaved	
Vegetation cover (%)	Fractional cover (PV, NPV) > 10 % for MMU <sup>1</sup>			
Biomass (Mg ha <sup>-1</sup> )	Mapping based on Texture > a			
Height (m)	SAR/LiDAR/texture			
	LiDAR/SAR interferometry			
Phenology	<b>Evergreen</b>	<b>Deciduous</b>	<b>Evergreen</b>	<b>Deciduous</b>
Winter	High NDVI	Low NDVI	High NDVI	Low NDVI
	Low PSRI	High PSRI	Low PSRI	High PSRI
Summer	High NDVI	High NDVI	High NDVI	High NDVI
	Low PSRI	Low PSRI	Low PSRI	Low PSRI
Canopy shape	<b>Excurent</b>	<b>Excurent</b>	<b>Decurrent</b>	<b>Decurrent</b>
	Area and shape of delineated crowns			

<sup>1</sup>Minimum Mapping Unit (MMU) of 0.04 ha or 400m<sup>2</sup>;

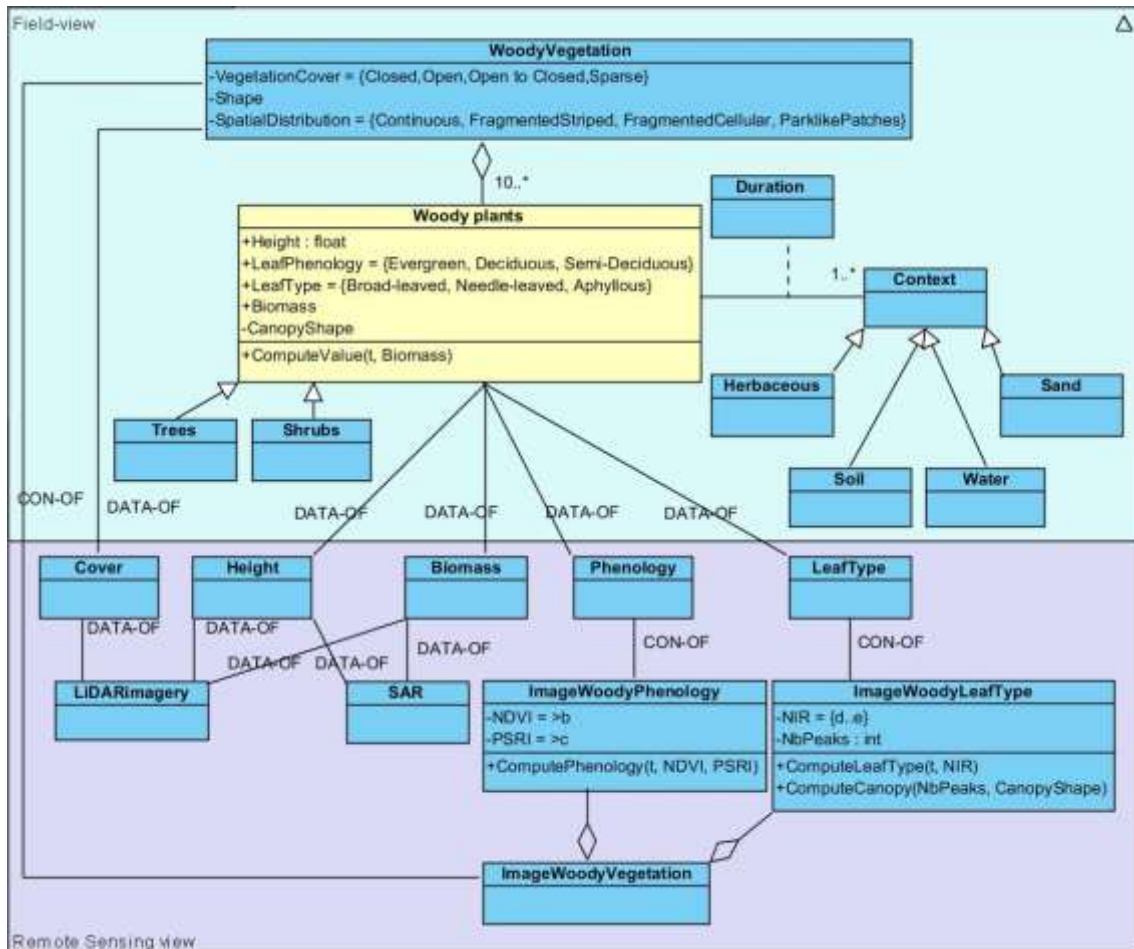

Figure F1.20. Semantic net template for vegetated trees and shrubs and (b) the remote-sensing point-of-view semantic net.

The template for **vegetated herbaceous** (Figure F1.17), which includes graminoids and forbs, considered differences in vegetation cover, with this ranging from sparse (tussock grasslands in Mediterranean areas) to closed (e.g., permanent grasslands in Wales). Perennial and annual plant types occur. Based on GHC definitions, the area covered needs to be > 0.04 ha. Their spatial distribution can be continuous or fragmented striped or cellular with park-like patches also observed (e.g., amenity grasslands). In terms of their biophysical properties, most are < 3 m in height and the leaf type is grass-like (grasses, reeds, sedges) or not grass-like. The AGB is typically low and < 5 Mg ha<sup>-1</sup> although the amount depends on the vegetation community occurring. A summary is given in Table F1.9.

Table F1.9. Values typical for vegetated herbaceous categories (based on template in Figure F1.16)

Type	Area /width	Height	Cover	Leaf Type	Leaf Phenology	Biomass
Graminoid	>	< 3 m	> 10 %	Grass like	Annual/	< 5 Mg ha <sup>-1</sup>
Not graminoid	0.04ha			Not grass like	Perennial	

<sup>1</sup>e.g., Gorse (*Ulex* species)

The height of herbaceous vegetation is difficult to discern from optical remote sensing data, although relationships between the AGB of graminoids (which relates



## D5.2 VHR land cover maps

in part to height) and reflectance in the red edge (associated with Worldview band 6) have been established (e.g., Wamunyima, 2005). Herbaceous vegetation is also often less than ~ 30 cm in height and the difficulty in separating vegetation in this height class from the underlying ground surface limits the use of LiDAR Canopy Height Models (CHMs) for classification. Nevertheless, some categories (e.g., bracken or *P. aquilinum*) can be discerned within LiDAR CHMs. Canopy cover can be determined by the presence of vegetation or otherwise within the minimum mapping unit (MMU), where this is classified as herbaceous, the area of delineated crowns within the MMU (Lucas et al., 2008), or through relationships established between field-based measures of cover and reflectance bands or derived indices (e.g., Armston et al., 2009).

To differentiate herbaceous categories from single-date imagery, differences in the reflectance characteristics but also indices such as the PSRI or NDVI can be exploited. For example, graminoid stands in the winter or dry periods (e.g., those dominated by *Molinia caerulea*) are often comprised of a large amount of non-photosynthetic vegetation and can be discriminated using the PSRI during periods of lower productivity. Using multi-temporal imagery, differences in the productivity as a function of management activities (e.g., ploughing, cutting or grazing) but also response to seasonal conditions (i.e., spring flush and leaf fall) can be exploited where these are manifested within the reflectance bands and indices. The following examples relate to the optical properties of herbaceous vegetation, with these listed in order of generally decreasing productivity.

- a) Permanent short grasslands, such as those grazed by stock in Wales, typically exhibit a high NIR reflectance throughout the winter, which is only reduced by grazing or following summer dry periods (*highly productive*).
- b) Vegetation communities dominated by forbs (e.g., bracken) typically exhibit a high  $PSRI_{win}$  because of the large amount of accumulated litter in the senescent period, which reduces during the spring flush when a full canopy cover often develops. These communities typically exhibit a very high NIR reflectance and NDVI during the growing season.
- c) In many upland regions (e.g., in Wales), acid grasslands are generally less productive and exhibit a consistently lower reflectance in the NIR and also NDVI. These grasslands also tend to support variable amounts of non-photosynthetic components.
- d) Grasslands dominated by species such as *M. caerulea* exhibit a moderate NDVI during the summer months and, during the winter, are characterized by a very low NDVI (equivalent to some non-vegetated surfaces) and a high PSRI.
- e) Annual grasslands (e.g., in Italy) are distinguished by their high productivity during the spring flush or after rain events, as reflected by a marked increase in the NDVI that is generally short lived. At other times, productivity is low or only a bare soil surface with non-photosynthetic components occurs (*least productive*).

For all herbaceous vegetation, reflectance data in the red, red-edge and near infrared wavelength regions provide best discrimination although continua and variability in the magnitude of these occur over time and complicates their classification from remote sensing data. The semantic net defined for the super-category of herbaceous vegetation is given in Figure F1.21. Values for Le Cesine, Cors Caron, Cors Fochno and the Netherlands are provided in later sections and data sources are indicated in Table F1.10.

## D5.2 VHR land cover maps

Table F1.10. Summary of the characteristics of herbaceous vegetation, as observed from remote sensing data, noting that multi-temporal imagery provide best discrimination.

	Graminoid		Non-graminoid	
	Annual	Perennial	Annual	Perennial
Cover (%)	NDVI or SR <sup>3</sup>	NDVI or SR	NDVI or SR	NDVI or SR
Biomass ~ height/cover	Red-edge LiDAR <sup>4</sup>	Red-edge LiDAR	Red-edge LiDAR	Red-edge LiDAR
Type <sup>1</sup>	NDVI	NDVI	NDVI	NDVI
Type <sup>2</sup>	PSRI	PSRI	PSRI	PSRI

<sup>1</sup>Based on productivity: improved, semi-improved or unimproved. <sup>2</sup>Based on amount of non-photosynthetic vegetation in the Type<sup>1</sup> category. <sup>3</sup>Simple ratio of red and near infrared. <sup>4</sup>Above ~30 cm

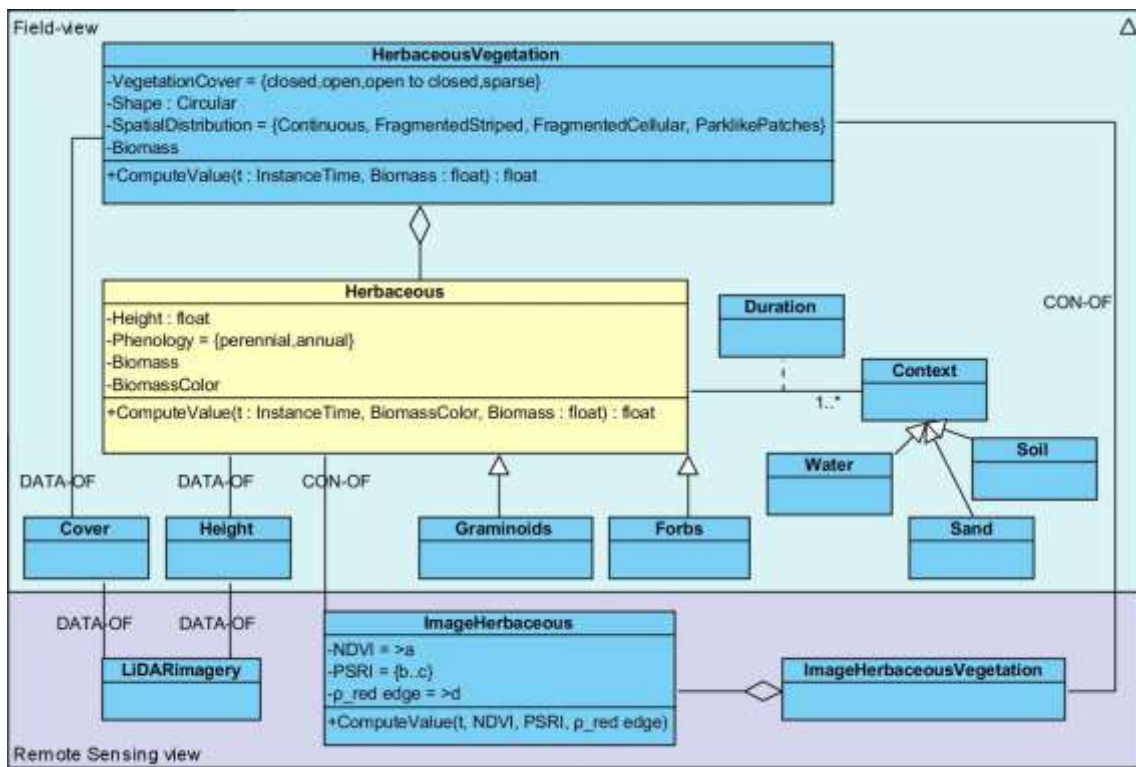

Figure F1.21. Semantic nets template for herbaceous vegetation areas. Typical values are given in Table F1.9. The actual rules applied are outlined in the sections following.

Most areas of agricultural **cultivation and under management** are enclosed by a boundary and are typically separated by a fence line, track, hedgerow, water or trees. However, in all landscapes and individually or collectively, enclosed units generally adjoin a semi-natural area (e.g., forests, heathlands), particularly where encroachment onto land that has previously been undisturbed, relatively undisturbed or recovering from previous disturbance. An example is given in Figure F1.22 for Le Cesine where olive groves are separated internally by 'field' boundaries but are interfaced externally by forest.



Figure F1.22. Cultivated areas (olive groves) separated by tracks and externally bordering forest.

Within the agricultural areas themselves, the crops may be herbaceous (e.g., maize, cabbage) or woody (e.g., orchards, olive groves). Typically, the crops are arranged in rows that are separated by some distance in order to allow for machinery to pass through or to operate during the growing and harvesting processes. For this reason, the amount of cover can vary, both spatially but also temporally. Variations in crop cycles leads to variations in biomass and productivity. Across units, cover is typically continuous although can be fragmented (as in the case of orchards) or parklike (e.g., allotments or gardens). The background is typically herbaceous vegetation, soil or water (as in the case of irrigated rice or cotton).

Classification of cultivated units from remote sensing data can be achieved using, for example, a spectral difference segmentation of the available spectral bands (typically a combination of visible and near infrared) to identify objects commensurate with the size of fields. The resulting objects, which are typically large for fields with a homogeneous crop or grass cover, can be more confidently assigned to a cultivated area where bounding linear features (e.g., hedgerows) occur. Such an approach is less effective where boundaries are less distinct (e.g., fencelines). Where cultivated areas cannot be automatically differentiated, the use of cadastral information is essential. Within the areas mapped as cultivated, different land cover categories can be mapped using several approaches:

- a) Utilizing rules that capture changes (or otherwise) in the NDVI, red edge and PSRI over an annual cycle (if seasonal data are available) or simply on the magnitude of these values themselves.
- b) If tree crops, identifying individual trees based on a finer (e.g., chessboard) segmentation at a hierarchical level below that of the larger objects representing field units and using, for example, counting procedures.
- c) Using directional measures or texture in the lower hierarchical level, which may indicate the arrangement of crops (whether woody or herbaceous) into rows.

Where forestry plantations occur, discrimination can be achieved using textural measures, particularly as spectral differences between forest types (e.g., needle-leaved and broad-leaved) may be small. Seasonal information can be used to better indicate differences between the plantation type whilst directional information can reveal planting of tree crops (e.g., coniferous trees) in rows. Figure F1.23 shows the template for this super-category and values used to differentiated cultivated and managed areas from those that are semi-natural or natural within Le Cesine, Cors Caron, Cors Fochno and the Netherlands are given in later sections.

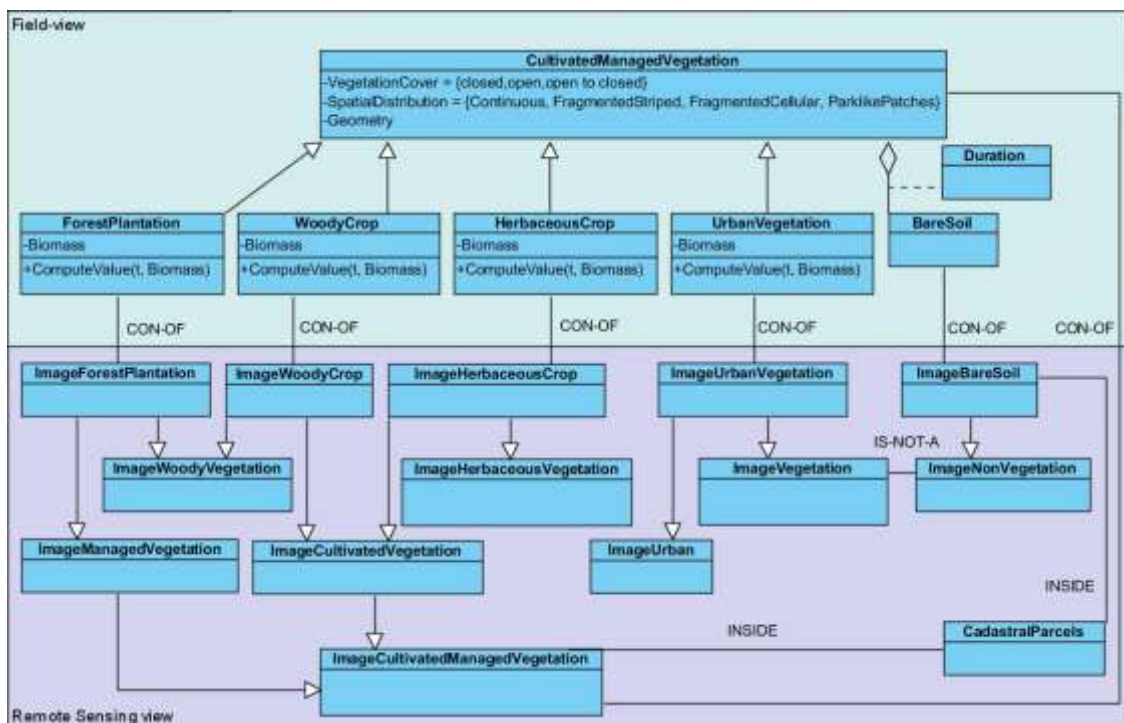

Figure F1.23. Semantic nets template for cultivated areas. The actual rules applied are outlined in the sections following.

**Urban areas** are especially diverse, consisting of vegetation, buildings, infrastructure (e.g., roads, railways) and waterbodies. The primary artificial elements are constructed and can be identified based on the attributes of area and geometry (e.g., rectangular, linearity). Within the built-up environment, industrial, residential and commercial buildings can be identified, with the density of these ranging from low to medium and the height varying from ground level through to several 100 m. Roads can be paved or unpaved and can be of varying length, width and geometry. Railways are linear features that are generally narrow, do not have abrupt changes in their direction and are bordered by non-vegetated areas (e.g., stones). Within the non-built up environment, waste dumps and extraction sites (e.g., quarries) are common examples.

Within remote sensing optical imagery, urban areas exhibit considerable spectral variability as a function of the materials used in their construction (particularly on roofs) and also the degree of shadowing as a function of sun illumination. A diversity of spectral bands and indices can be used to differentiate components of the urban environment (e.g., metal, slate or clay roofs, shadows, gardens), which can then be combined to represent individual structures (e.g., buildings) or facilities (e.g., leisure centres with tennis courts, astroturf, outdoor swimming pools). Typically, urban areas as well as infrastructure (roads, railways) exhibit a low NDVI and high visible reflectance where vegetation does not occur or is sparse. However, finer

definition of urban structures is difficult within VHR data acquired at 1-2 m spatial resolution. For this reason, existing digital layers representing infrastructure was used with areas identified outside of the mapped area associated with expansion of the urban area or transport infrastructure. Within the urban areas, vegetated areas associated with gardens or sporting fields are identified, as these typically were adjacent to the artificial structures. Extraction sites are often characterized by their higher or lower elevation compared to surrounding areas and heterogeneity in terms of texture. The template representing semantic nets for the urban super-category is given in Figure F1.24 and specific rules for the various study sites are given in later sections.

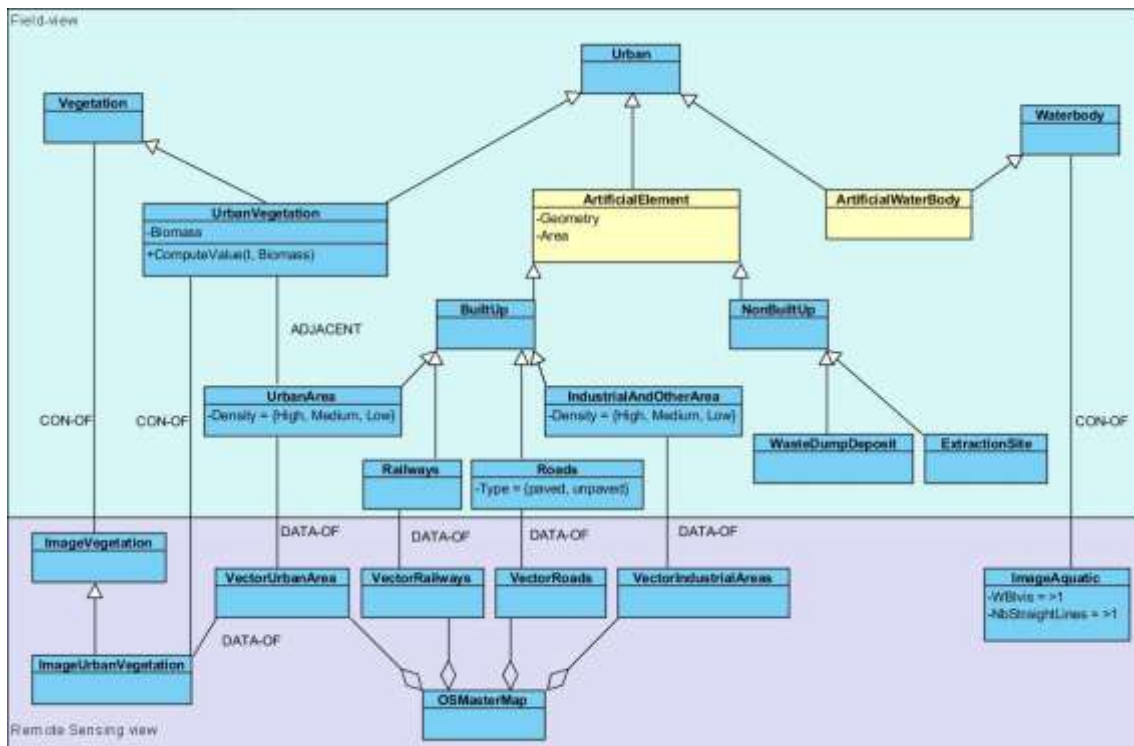

Figure F1.24. Semantic nets template for urban areas. The actual rules applied are outlined in the sections following.

**Sparsely vegetated** areas outside of the urban areas are typically natural/semi-natural and include terrestrial surfaces (e.g., beaches, sand dunes, sandflats, mudflats, gravel, shingle and rocks) and aquatic areas (artificial and natural waterbodies). Terrestrial surfaces associated with marine, estuarine, lacustrine or riverine deposits are typically low lying (if on the coast) and of low relief (with the exception of sand dunes). Depending on the water levels, many of these surfaces can be adjacent to salt, brackish or freshwater or to other surfaces. For example, shingle at the top of a beach will be adjacent to water at high tide but to sand at low tide. Many areas are extensive and are relatively homogeneous in terms of the material occurring. Rock surfaces are typically steep and often adjacent to vegetated areas (in the case of scree) or other sparsely vegetated surfaces (e.g., sand beaches). Natural waterbodies include the ocean/sea, estuaries, lagoons, lakes, ponds and rivers and streams. In general, extensive areas of open water occur which may be flowing or static, clear or turbid, deep or shallow. Artificial waterbodies are typically associated with infrastructures such as dam walls, as illustrated previously for reservoirs.

## D5.2 VHR land cover maps

Many surfaces are readily distinguishable from remote sensing data as they:

- Are close to water (e.g., mudflats) or occur in zonation patterns as a function of distance from water and proximity to other sparsely vegetated surfaces (e.g., mudflats occur next to saltmarshes)
- Exhibit a generally low NDVI throughout the year.
- May be inundated over varying time frames, from diurnal to sub-annual and exhibit a high WBI.
- Exhibit a relative low texture in many spectral bands.

In addition, differences between water of varying levels of turbidity can be differentiated with reference to the visible bands in particular. Furthermore, the Worldview coastal band provides separation between saltwater and freshwater systems. The template representing semantic nets for **sparsely vegetated areas** is given in Figure F1.25, with a net for waterbodies given in Figure F1.26. The values used in the classification for the various study sites are provided in later sections.

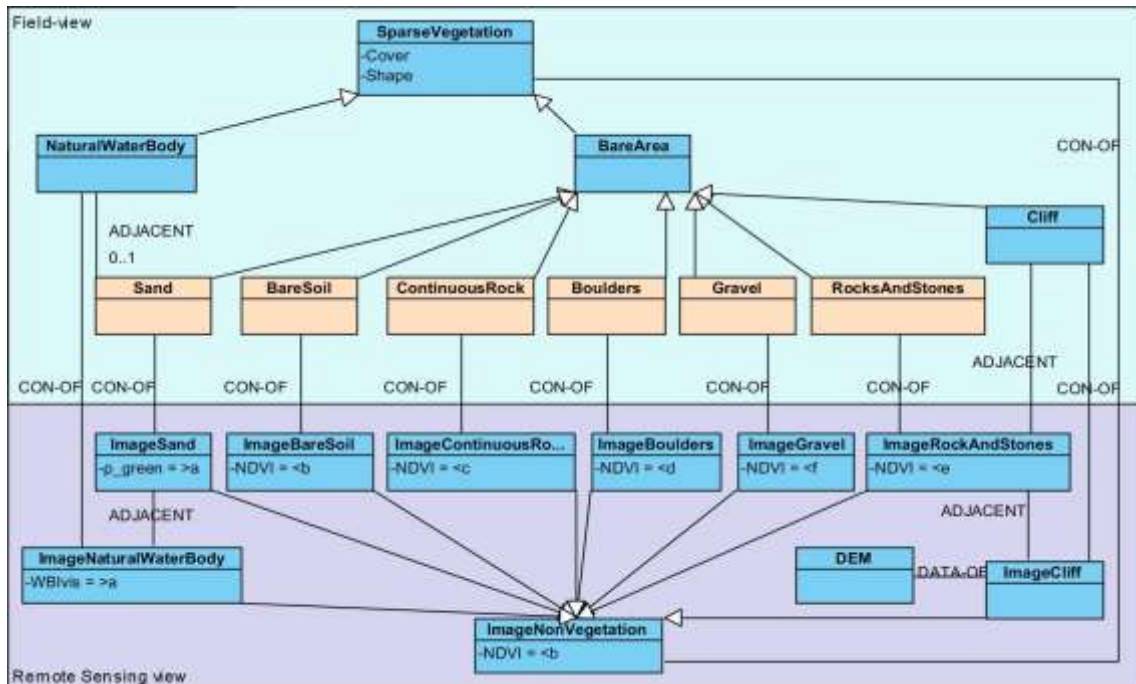

Figure F1.25. Semantic nets template for sparsely vegetated areas. The actual rules applied are outlined in the sections following.

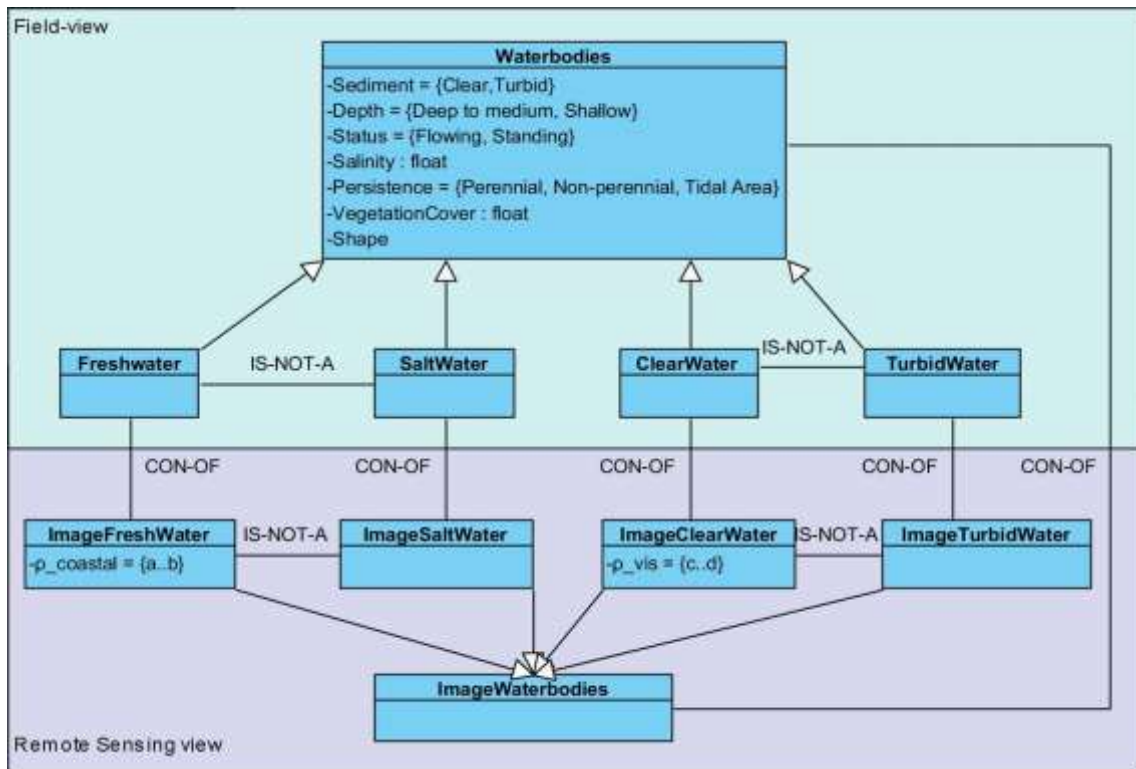

Figure F1.26. Semantic nets template for waterbodies. The actual rules applied are outlined in the sections following.

In summary, the study has established a series of semantic net templates that initially describe how LCCS categories up to Level 3 can be identified in the field and discriminated using remote sensing data using combinations of spectral bands and derived indices that are consistent within and between sites, although values vary as a function of the image data used. Templates are then established for five land cover categories which correspond to the GHC super-categories. Within these, a range of information is used to differentiate subcategories that relate to LCCS categories and GHCs, with these often been matched on a one-to-one basis. However, many-to-one and one-to-many relationships also exist and the focus of BIOSOS is to develop methods that allows robust translation between these different systems, thereby allowing better and concurrent mapping of land covers and habitats. The templates used have algebraic values which vary with each site depending on the imagery available and their dates of acquisition and a summary of these is provided in the following sections and based on the classification rules implemented in eCognition.

### F1.3.1.2 Classification of LCCS categories beyond Level 3.

As with the classification of LCCS categories to Level 3, the same imagery were used for each site, although LiDAR data were included for the Netherlands and Cors Fochno. The following sections present the VHR maps for the four sites and the rules used in their generation.

#### Single date VHR spaceborne data

For Cors Fochno, Cors Caron and the Netherlands, Worldview II data were acquired in November, 2001, April 2011 and June 2011 respectively. For these three sites, the use of single-date imagery acquired just prior to the spring flush, close to the peak of plant biomass production and during the senescence period was evaluated in terms of assigning LCCS categories. In each case, the classification followed the logic expressed in the semantic nets, which coupled knowledge of field ecology with that

## D5.2 VHR land cover maps

of remote sensing scientists. For all three sites, the classification focused on the semantic nets that were based around the GHC supercategories of urban, crops, sparsely vegetated areas, vegetated trees and shrubs and vegetated herbaceous. Following from the 'image-based' inputs to the semantic nets given in the previous section, the classifications were generated using the data and values are given for Cors Caron (Table F1.11), Cors Fochno (Table F1.12) and the Netherlands (Table F1.13). The maps for each are also provided in Figures F1.27 a) and b) and F1.28 respectively.

For **Cors Caron and Cors Fochno** in Wales, the rules used for the classification of the LCCS categories were similar with the exception of those used to define the active raised bog. This was attributable to the use of imagery acquired during different seasons (April and November respectively). The mapping from the November imagery was compromised by the low sun angle which lead to shadowing within the hilly terrain and particularly within forests. Differences in tidal levels also compromised the classification of the coastal area. The classification provided a good representation of the different habitats occurring although refinement of the mapping for Cors Fochno is being undertaken by including the Worldview II image from July, 2011, and also the LiDAR and hyperspectral data (to be fully reported in Deliverable 5.4).

Objects associated with the urban areas and infrastructure were well defined using the spectral difference segmentation. Without the use of ancillary data, the category was mapped using NDVI thresholds and roads and railways were then separated from buildings based on their greater linearity. Areas of **water** were identified using the WBI. Clear and turbid water was separated based on differences in the visible spectrum. The presence of straight edges also identified artificial water bodies as did areas identified but not included in historical water body layers on the assumption that these had been created subsequently.

For the **Netherlands**, the number of LCCS categories was relatively low but similar inputs to the classification as that generated for the Wales sites were used. Within the forest categories, differentiation to different height categories was further achieved using the LiDAR data, with these described in terms of GHCs in the map shown. However, further refinement to the classification is required together with an evaluation of the benefits of including LiDAR and hyperspectral data.



D5.2 VHR land cover maps

a)



b)



Figure F1.27. Classifications of LCCS categories beyond Level 3 for a) Cors Fochno and b) Cors Caron.

D5.2 VHR land cover maps

Table F1.11 Summary of rules used for discriminating LCCS life forms based on single-date imagery (Cors Caron)

Life form	LCCS	Them.	Feature	Classified as	NDVI	Red	Red edge	NIR2	Red/Red edge	480/842
<b>Surface aspect and physical status</b>										
1. B15_A4_A13		1	<0.2							
2. B15_A3_A8		1								
3. B27_A1.B1.C1_A5		≠1								
4. B28_A1.B1.C1_A5		1	Length							
5. B28_A1.B1_C2.A4		1	Length							
6. B16_A5	B16									
<b>7. Life form</b>										
8. A11_A3.A4.B1.B5.C1.D1.D9_B4			Area < 15 ha		> 0.45					
9. A11_A1.B1.B5.C1.D1.D9_A8.B4					<= 0.6		< 12.5			
10. A12_A2.A6.A10.B4.C1.E5_B12.E6					0.16 ∩ 0.36		10.0 ∩ 23.6			
11. A12_A6.A20.B4.C1.E5_B1.E6						15.0 ∩ 21.5				
12. A12_A6.A10.B4.C1.E5_B13					10.5 ∩ 0.7	15.0 ∩ 21.0				
					>= 0.3	12.0 ∩ 16.0				
13. A24_A1.A4.A20.B3.C1.D1.E1.F2.F4.F7.G4_C4					< 0.38				> 0.64	< 1
14. A12_A1.A3.A10.B2.C2.D1.E2_B5						4.0 ∩ 60.0	5.0 ∩ 18.0	8.0 ∩ 19.0		
15. A12_A1.A4.A11.B3.C2.D1.E2.B14			Area < 100m <sup>2</sup> Distance to (8) < 20 m					>=21.5		
16. A24.A3.A12.E2.C1.D1.E2_C4					0.25 ∩ 0.55				<= 0.81	
					> = 0.38				< 0.68	

D5.2 VHR land cover maps

Table F1.12. Summary of rules used for discriminating LCCS life forms based on single-date imagery (Cors Fochno)

LCCS Category	LCCS	Them.	Feature	Classified as	NDVI	Red	Red edge	NIR2	Red/Red edge	480/842
<b>Surface aspect and physical status</b>										
1. B15_A4_A13		1	<0.2							
2. B15_A3_A8		1								
3. B27_A1.B1.C1_A5		=! 1								
4. B28_A1.B1.C1_A5		1	Length							
5. B28_A1.B1_C2.A4		1	Length							
6. B16_A5	B16									
<b>Life form</b>										
7. A11_A3.A4.B1.B5.C1.D1.D9_B4			Area < 15 ha		> 0.45					
8. A11_A1.B1.B5.C1.D1.D9_A8.B4					<= 0.6		< 12.5			
9. A12_A2.A6.A10.B4.C1.E5_B12.E6					0.16 ∩ 0.36		10.0 ∩ 23.6			
10. A12_A6.A20.B4.C1.E5_B1.E6						15.0 ∩ 21.5				
11. A12_A6.A10.B4.C1.E5_B13					10.5 ∩ 0.7	15.0 ∩ 21.0				
					>= 0.3	12.0 ∩ 16.0				
12. A24_A1.A4.A20.B3.C1.D1.E1					0.2 ∩ 0.46		9.0 ∩ 15.0		> 0.64	
13. F2.F4.F7.G4_C4										
14. A24_A6.A13.B4.C1_B13.C5			Border to Saltwater OR Border to(14)		0.0 ∩ 0.65		8.0 ∩ 23.0			
A12_A1.A3.A10.B2.C2.D1.E2_B5						4.0 ∩ 60.0	5.0 ∩ 18.0	8.0 ∩ 19.0		
A12_A1.A4.A11.B3.C2.D1.E2.B14			Area < 100m <sup>2</sup> Distance to A11_A3.A4.B1.B5.C1.D1.D9_B4 < 20 m	A12_A1.A3.A10.B2.C2.D1.E2_B5				>=21.5		
A24.A3.A12.E2.C1.D1.E2_C4					0.37 ∩ 0.60		15.0 ∩ 25.0			

D5.2 VHR land cover maps

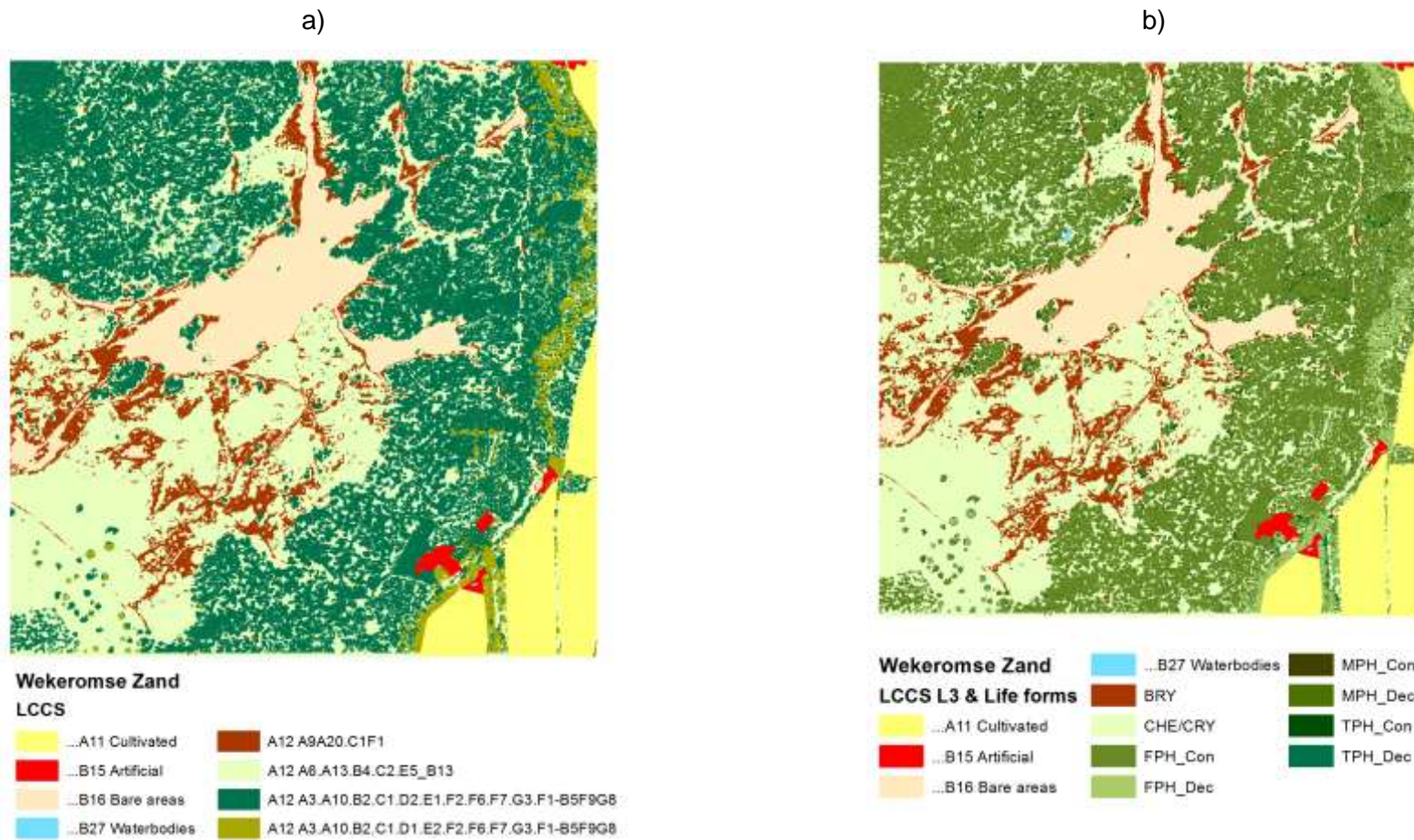

Figure F1.28. Classifications of a) LCCS categories and b) their translation to GHCS for Wekeromse Zand, the Netherlands.

## D5.2 VHR land cover maps

Table F1.13 Summary of rules used for discriminating LCCS life forms based on single-date imagery (the Netherlands)

LCCC Category	Them.	Feature	NDVI	NIR2	NIR-Red Difference
1. B15_A4_A13	1				
2. B15_A3_A8	1				
3. HER/CHE/CRY			$\geq 0.255$	$\geq 0.34$	$\geq 0.243$
4. HER/BRY			$< 0.254$	$< 0.34$	$< 0.07$
5. A11_A3.A4.B1.B5.C1.D1.D9_B4					
6. A12_A2.A6.A10.B4.C1.E5_B12.E6					
7. TRS/MPH/DEC		CHM > 60 AND $\leq 200$			$\geq 0.26$
8. TRS/MPH/CON		CHM > 60 AND $\leq 200$			$< 0.26$
9. TRS/TPH/DEC		CHM > 200 AND $\leq 500$			$\geq 0.26$
10. TRS/TPH/CON		CHM > 200 AND $\leq 500$			$< 0.26$
11. TRS/FPH/DEC		CHM > 500			$\geq 0.26$
12. TRS/FPH/CON		CHM > 500			$< 0.26$

### Legends

	Urban
	Sparsely vegetated
	Crops
	Vegetated herbaceous
	Vegetated trees and shrubs

	AND
	Growing rule
∩	Fuzzy classification
≠	Not equal to
1	OR statement with item below

Description	Life form
Surface aspect and physical status	
Urban	B15_A4_A13
Roads	B15_A3_A8
Water	B27_A1.B1.C1_A5
Natural standing	B28_A1.B1.C1_A5
Natural flowing	B28_A1.B1_C2.A4
Bare Areas	B16_A5
Life form	
Agricultural	A11_A3.A4.B1.B5.C1.D1.D9_B4
Conifer plantation	A11_A1.B1.B5.C1.D1.D9_A8.B4
Tall grasslands (e.g., with Molinea)	A12_A2.A6.A10.B4.C1.E5_B12.E6
Medium to tall grassland (e.g., Phragmites)	A12_A6.A20.B4.C1.E5_B1.E6
Closed short grass	A12_A6.A10.B4.C1.E5_B13
Active bog	A24_A1.A4.A20.B3.C1.D1.E1.F2.F4.F7.G4_C4
Broad-leaved woodland	A12_A1.A3.A10.B2.C2.D1.E2_B5
Broad-leaved scrub	A12_A1.A4.A11.B3.C2.D1.E2.B14
Broad-leaved woodland (carr)	A24.A3.A12.E2.C1.D1.E2_C4

### **F1.4 Accuracy assessments for the test sites**

For each of the test sites, assessments of classification accuracy are still ongoing because of the need to better integrate the range of available ground truth data, with these collected during the course of the project but also collated from existing sources. These will be reported in Deliverable D5.4. Indicative accuracies for Cors Caron and Cors Fochno are in the order of 60 % overall. As expected, the greater accuracies were associated with the more extensive land cover categories (e.g., active raised bog > 80 % for both users and producers) but was less for land covers with a more scattered distribution or with linear geometry (e.g., hedgerows). Assessments of accuracy are ongoing for the Italian and Dutch sites.

## G1. Discussion

### G1.1 Overview

The research undertaken within D5\_2 has led to a common language being developed between field ecologists and remote sensing scientists that has been broadly represented within semantic nets. Using an image segmentation and rule-based classification approach implemented within eCognition and based on the FAO LCCS, land cover maps to Level 3 have been consistently generated for four diverse sites in Italy, Wales and the Netherlands. However, for a more detailed classification (to life form, surface aspect and persistence), more site-specific rules need to be generated primarily because of the uniqueness of habitats in the sites studied but also the different dates and types of imagery used. Whilst a large amount of ground truth data have been collected for all sites, the establishment of error matrices and associated measures of classification accuracy is considered premature given the diversity of land covers occurring and the range of image data and acquisition dates. For this reason, accuracy levels will be reported in D5.4.

The following sections provide a more in depth discussion of ontologies and semantic nets for the description land cover categories and habitats, the use of LCCS as a basis for mapping land covers and the relative benefits of using single-date or multi-date imagery. The classifications generated using SIAMTM spectral categories and the approach adopted within eCognition are also compared and an assessment of the procedures undertaken. Finally, the anticipated benefits of integrating hyperspectral and LiDAR data are indicated.

### G1.2 Ontologies and semantic nets for land cover and habitat class description

The ontology-based approach proposed in BIO\_SOS for describing land cover and class description, based on *a priori* knowledge, is innovative. However, the method is still being developed and various issues that have arisen with the method during the course of this work are outlined below:

- *Difficulties in establishing a consensus among experts from different scientific areas (computer sciences, geography, remote sensing and ecology):* The challenge in building consensus between these various domains was particularly evident when working together to build semantic nets describing land cover classes. Many issues appeared regarding the different concepts and corresponding terms used in each particular scientific domain. For instance, an object for a computer scientist does not have the same meaning for a remote sensing specialist. It is essential to address such conflicts if the method for knowledge representation is to be accepted by all members of the scientific community. Therefore, consensus can only be achieved through discussion between the project partners in order to identify common objectives.
- *Finding a compromise between the “bottom-up” and “top-down” approach:* According to the expertise of each partner, the approach to assigning class descriptions to spectral categories in the imagery might differ. For example, computer scientists favor the model-oriented approach (i.e., the model should firstly be conceptualized and then tested on concrete cases in the imagery). This requires that theoretical work be first carried out to finalise the concepts and ontological architecture used in the final model. In contrast, ecologists and remote sensing experts agree that the approach should first involve tests on the imagery in order to conceptualize the models. Although both approaches are correct within their respective disciplines, the model conceptualization should ideally be carried out with methods shared between both approaches.
- *Identifying existing ontologies and thesaurus that are relevant:* Many ontologies and thesaurus are now available online that can be used as a guide to establishing a common vocabulary. However, assessing the relevancy of a particular ontology or thesaurus to the context of the project remains challenging. It is also necessary to identify which parts of the ontologies are

useful for us. For instance, the AGROVOC thesaurus from FAO includes thousands of terms that are not all useful in the project. More work is therefore needed to refine an appropriate ontology to address this point.

- *Linking ontologies, thesaurus and nomenclatures:* Since various ontologies, thesaurus or ontologies are available, it will be a challenging task to bridge the gap between these so that they can be used in conjunction with one another.
- *Adaptation to new tools:* The UML language has been chosen as a means to convey expert knowledge in the form of conceptual diagrams. Most of the partners who were not familiar with such an approach, were nevertheless expected to adapt to the terminology and functions of the UML diagram. The first semantic nets built with UML allowed us to highlight various limitations of the method such as:
  - The difficulty in linking with a large number of concepts that attempt to describe complex relations (spatial, temporal...)
  - The difficulty to differentiate concepts and attributes (an evergreen forest is both a subclass of a forest and a forest with an attribute LeafPhenology = evergreen)
  - The main differences between concepts are the constraints that are applied to the object attributes (e.g., the limits on vegetation height).

Therefore, efforts have to be made to identify a method to use constraints in UML. To solve these three issues, we might need to study three other techniques/tools:

- OCL (Object Constraint Language) that could allow us to include constraints in the UML diagrams.
- Description logics, which is a formal language for knowledge representation, and can help us to consider constraints more easily.
- Protégé software will be used to build ontologies that can deal with the high number of concepts used, and is based on description logics.

The issues highlighted here have arisen during the conceptualization phase of the first year of the project. There is now a necessity to move to the following phases: ontologization and operationalization.

### **G1.3 LCCS categories as a basis for mapping**

The use of LCCS categories for the classification of remote sensing data was considered to be most effective in relatively homogeneous and contiguous areas. However, the LCCS taxonomy is less suited to complex environments where height information is required to discriminate categories. In these cases, a surrogate for height (e.g., texture, degree of shadowing) is usually used whereas a better classification could simply be achieved by including direct measures of height, such as that provided by LiDAR, stereo photography or even radar interferometry.

In general, however, the LCCS categories to Level 3 provided a strong basis for providing a consistent classification of land covers between sites. The main difficulty arose with the classification of the aquatic vegetation types, as these are not always readily distinguishable from terrestrial vegetation. For example, active raised bogs in Wales were quite dry at the time of observation but beneath the surface, were waterlogged. Discriminating such categories based on biophysical measures is challenging and arguably requires the use of other data sources (e.g., low frequency SAR). The classification of life forms, surface aspect and persistence was difficult to achieve consistently between sites because of the uniqueness of habitats or the poor timing of image acquisition.

### **G1.4 Use of single-date versus multi-date multi-spectral imagery and inclusion of hyperspectral and LiDAR data.**

Whilst a number of categories (e.g. open water, sand dunes) can be mapped with the use of single date imagery, better discrimination of habitats can be achieved by using a multi-date approach because of



differences in vegetation phenology. For specific classes, it is even often a prerequisite to have a multi-seasonal approach (.e.g. to distinguish winter wheat from grassland, or to distinguish specific grassland species such as *Molinia caerulea* from *Deschampsia flexuosa*). For example, comparison of the July and November Worldview II images acquired over Cors Fochno suggested better discrimination of several subcategories (e.g., components of the active raised bog such as sphagnum pools and swards of *Eriophorum* and *Phragmites*) and grassland habitats as well as broad-leaved and needle-leaved woodlands.

Although multi-temporal datasets are considered to be beneficial and indeed essential when mapping land covers from satellite sensor data, hyperspectral imagery can provide additional benefits including the provision of a) additional bands to assist delineation of objects (e.g., tree crowns), b) endmember fractions that assist discrimination of species groups or retrieval of biophysical properties (e.g., non-photosynthetic fractions) and c) assessment of health indicators suggesting trends in habitat condition. A greater range of classification algorithms can also be implemented which go beyond the simple rule-based approach. The inclusion of LiDAR data also provides information on the 3D structure of vegetation, which can be used to assist classification. Both LCCS and GHC classification schemes incorporate height information, which makes it very convenient to use a canopy height model.

The use of multi-temporal imagery supplemented by hyperspectral and LiDAR data is currently advocated for BIO\_SOS and the benefits will be reported in Deliverable 5.4.

### **G1.5 Comparison of the SIAM™ and eCognition approach**

An objective of D5.2 was to provide a comparison of the relative advantages and disadvantages of the SIAM™ spectral classification and the eCognition approach. The comparison was undertaken for the Italian site and was also based on knowledge obtained through classification of moderate spatial resolution SPOT and Landsat sensor data. The comparison indicated that the segmentation and classification generated using spectral reflectance data and indices were better compared to those generated using SIAM in that the segmentation was crisper and more categories of, for example, vegetation (e.g., submerged, non photosynthetic) could be identified. The procedure was well suited to the use of Worldview II data because of the greater availability of spectral wavebands. It should be noted that the SIAM™ software executable modules are still not available for the Consortium following the withdrawal of Partner 15.

Table G1.1. A comparison of the SIAM™ spectral classification and eCognition segmentation and rule-based classification approach.

<b>SIAM™ Spectral classification</b>	<b>eCognition segmentation</b>
<b>Overview</b>	
Provides a hierarchical per-pixel pre-classification of a single-date single-sensor input image based on spectral similarity and differences, with each pixel assigned to a spectral category associated with a semantic label	Provides a hierarchical segmentation of the input image(s) based on spectral similarities and differences which allows spectral super-categories (e.g., vegetation, water) to be discriminated. A spectral sub-category with a semantic label is not assigned
<b>Advantages</b>	
SIAM™ is operational. Once reflectance data are analyzed within SIAM™, the second classification stage can be based on an interpretation of spectral categories and derived indexes	Multi-temporal data sets can be easily stacked and processed. Allows for an ecological and biophysical interpretation of the imagery
<b>Disadvantages</b>	
Due to the reduced number of spectral bands in VHR imagery, the mapping of spectral categories to target output classes may be one-to-many or many-to-many, particularly for the vegetation strata. The development of multi-temporal rules is required for dealing with output of SIAM™ maps from multi-date images within the EODHaM 2 <sup>nd</sup> stage.	Pre-operational
Boundaries of segments do not necessarily correspond to the shape of the object (e.g., olive trees).	Requires consistency in the layers and values used for classification which may compromise reproducibility
Some complex categories (e.g., bogs) are represented by a single segment.	
Incorporation of soft classifications difficult (e.g., based on spectral unmixing, fuzzy classification)	

## H1. Conclusions

The main conclusions from the study are:

- a) Direct mapping of LCCS can be achieved through use of VHR multi-spectral data with improvements most likely to be achieved through integration of data acquired several times over a growing season. The Worldview II sensor with the availability of additional bands in the coastal, yellow, red edge and near infrared regions is likely to significantly benefit the classification of land covers.
- b) Canopy height information is ideally required for GHC habitat classification and methods should be investigated to derive such information (e.g., LIDAR-derived canopy height model).
- c) A standard rule set in eCognition can be routinely applied across all sites for level 3 discrimination of LCCS categories but must be adjusted to local circumstances for more detailed classifications (e.g., of life forms). A prerequisite for consistent classification across all sites is that methods for the correction of input products in eCognition are standardized as much as possible.
- d) The work has so far considered TOARF as the standard EO product. However, it would be preferable to use surface reflectance as a standard input product so that the classification outputs from the rule sets are as true to life as possible.
- e) The definitions of, and relationships between, classes are not easy to understand, especially when different typologies are involved. Semantic networks therefore provide a more concise description of the different class components and their interrelationships. The condensed-knowledge formats of the semantic net aids users to interpret the class descriptions, the classified imagery themselves and finally can assist in setting up an operational habitat classification system in which the translation between GHC and LCCS is possible.
- f) LCCS categories are sometimes difficult to use in the real world context, especially when using codes lower than Level 3 (for example, in defining life forms, surface aspect and physical status), as several combinations of codes can describe the same land cover. A potential option is to use the Level 3 classification of the LCCS as a starting point for the identification of GHC super categories from which lifeforms can be readily identified. Lifeforms (and associated GHCs) are easier to use and are limited in number. Wise combinations of both the LCCS and GHC methodologies will undoubtedly improve the classification accuracies.
- g) Semantic nets can integrate both the field and the remote sensing point-of-view, facilitating the goal of knowledge exchange between the multi-disciplinary components of the BIOSOS project. A set of attributes and operations, along with temporal and spatial relations, is used to describe in detail both the intrinsic characteristics of the habitats, and their remote sensing properties, as illustrated by the extraction rules.
- h) In order to reduce the number of the semantic nets, template nets have been developed which act as a guide to the bottom-level semantic nets of the habitats observed in any landscape. The architecture of the semantic nets offers scalability and extendibility and can be adapted to any habitat following the same conventions adopted in the template nets.
- i) Whilst full accuracy estimates have not been reported in this deliverable, these will be conveyed in D5.4 where a comparison between the use of single date, multi-date, hyperspectral and/or LiDAR data inputs will be provided.

**PART 2**

# **KNOWLEDGE-DRIVEN LAND COVER AND LAND USE DESCRIPTIONS**

## A2. Class description for Le Cesine site

### A2.1 IT4 site

N°*	LCCS-DIC	DESC LCCS-DIC	LCCS		DESC LCCS -HIER	HABITAT
			HIER	ENVIRONMENTAL ATTRIBUTES		
1	A12	Natural and seminatural terrestrial vegetation	A2.A5.E7	O3.M233.N12-AC	Herbaceous.Forbs.Annual	E1.6
6				O3.M233.N3.N12-AR		1210
8(8.1)						2230
8(8.2)				O3.M233.N6.N12-LP		(too little for the mapping in IT4)
2			A1.A4.D1.E2		Woody.Shrubs.Broad-leaved.Deciduous	F5.51
3			A1.A4.D2.E1		Woody.Shrubs.Needle-leaved.Evergreen	2250
4			A1.A4.D1.E1	O3.M213.N12-AR	Woody.Shrubs.Broad-leaved.Evergreen	F6.2C
5(5.1)				O3.M213.N12-LP		5330
5(5.2)				O3.M233.N12-LP		F5.514
7			A2.A6.E6		Herbaceous.Graminoids.Perennial	2110
9(9.1)	A24	Natural and seminatural aquatic or regularly flooded vegetation	A2.A5.E7	R1.O3.M233	Herbaceous.Forbs.Annual	3170
9(9.2)				R3/R2.O3.M213+N2+N12-SC		1310/A2.51
9(9.3)				R3/R2.O3.M213+N2+N12-SC		1310/A2.55
10			A1.A4.D3		Woody.Shrubs.Aphyllous	1420
11(11.1)			A2.A6.E6	R2/R3.O3.M213.N12-SC	Herbaceous.Graminoids.Perennial	1410
11(11.2)				R1.O3.M233.N12-HS		7210
11(11.3)				R2/R3.O3.M233.N12-HS		D5.1

D5.2 VHR land cover maps

11(11.4)				R2/R3.O3.M233.N12-SC		D5.2
12				R1/R2.O3.M233		C2
13			A2.A5.E6		Herbaceous.Forbs.Perennial	1150
14	A11	Cultivated and managed terrestrial areas	A3.A5		Herbaceous.NonGraminoids	I1.3
15			A1.A7.A9.W8		Trees.Broad-leaved.Evergreen.Orchards	G2.91
16			A1.A8.A9.W7		Trees.Needle-leaved.Evergreen.Plantations	G3.F1
17	B15	Artificial surfaces and associated areas	A1.A4.A13.A17		Built-up.Non-linear.UrbanAreas.Scattered	J2.1
18			A1.A3.A7.A8		Built-up.Linear.Roads.Paved	J4.2

\*Refer to Table 6.1, Deliverable 5.1

The description of each LC class is provided in a separate Table. First, the title of each Table reports dichotomous and hierarchical codes. Then the Environmental and Technical attributes are identified and their codes are added and explicated within the table. Subclasses are identified and described according to their correspondence to final habitats (Annex I or Eunis) whose description is also provided.

In the description of the attributes:

- “None” is used when the attributes are not relevant for class discrimination.
- “No data” is used when the attributes are not available.

The seasonal phenology of each LC class is reported in Figure 1. For LC natural aquatic classes the seasonal water coverage is reported in Figure 2.

D5.2 VHR land cover maps

LC Classes – Seasonal Phenological characteristics

LCCS	HABITAT	JAN	FEB	MAR	APR	MAY	JUN	JUL	AGO	SEP	OCT	NOV	DEC
A11/A1.A7.A9.W8	G2.91 - for												
A11/A1.A7.A9.W8	G2.91 - bac												
A11/A1.A8.A9.W7	G3.F1 - for												
A11/A1.A8.A9.W7	G3.F1 - bac												
A11/A3.A5	I1.3												
A12/A2.A5.E7	1210												
	6220												
	E1.6												
A12/A1.A4.D1.E2	F5.51												
A12/A1.A4.D2.E1	2250												
A12/A1.A4.D1.E1	F6.2C												
	F5.514												
	5330												
A12/A2.A6.E6	2110												
A24/A2.A5.E7	1310												
	3170												
A24/A1.A4.D3	1420												
A24/A2.A6.E6	1410												
A24/A2.A6.E6	7210												
A24/A2.A6.E6	D5.1												
A24/A2.A6.E6	D5.2												
A24/A2.A6.E6	C.2												
A24/A2.A5.E6	1150												
	Dense vegetation and/or peak of biomass												
	Sparse (younger) vegetation or minor green biomass												
	Minor biomass with withered/dry plants (or part of plants)												
	Bare soils (or water in A24) with remnants of withered/dry plants												

Figure 1: LC Classes for IT4 “Le Cesine” test site- Seasonal Phenological characteristics

D5.2 VHR land cover maps

LC Classes – Seasonal Water Coverage

LCCS	HABITAT	JAN	FEB	MAR	APR	MAY	JUN	JUL	AGO	SEP	OCT	NOV	DEC
A24/A2.A5.E7	1310	Water	Water	Water	Wet or waterlogged soil	Wet or waterlogged soil	Wet or waterlogged soil	Dry (at the surface) soil	Dry (at the surface) soil	Dry (at the surface) soil	Dry (at the surface) soil	Water	Water
	3170	Water	Water	Wet or waterlogged soil	Wet or waterlogged soil	Wet or waterlogged soil	Dry (at the surface) soil	Dry (at the surface) soil	Dry (at the surface) soil	Dry (at the surface) soil	Dry (at the surface) soil	Water	Water
A24/A1.A4.D3	1420	Water	Water	Water	Wet or waterlogged soil	Wet or waterlogged soil	Wet or waterlogged soil	Dry (at the surface) soil	Dry (at the surface) soil	Dry (at the surface) soil	Wet or waterlogged soil	Water	Water
A24/A2.A6.E6	1410	Water	Water	Water	Wet or waterlogged soil	Wet or waterlogged soil	Wet or waterlogged soil	Wet or waterlogged soil	Dry (at the surface) soil	Wet or waterlogged soil	Wet or waterlogged soil	Water	Water
A24/A2.A6.E6	7210	Water	Water	Water	Wet or waterlogged soil	Wet or waterlogged soil	Wet or waterlogged soil	Wet or waterlogged soil	Wet or waterlogged soil	Wet or waterlogged soil	Wet or waterlogged soil	Water	Water
A24/A2.A6.E6	D5.1	Water	Water	Water	Wet or waterlogged soil	Wet or waterlogged soil	Wet or waterlogged soil	Dry (at the surface) soil	Dry (at the surface) soil	Dry (at the surface) soil	Wet or waterlogged soil	Water	Water
A24/A2.A6.E6	D5.2	Water	Water	Water	Wet or waterlogged soil	Wet or waterlogged soil	Wet or waterlogged soil	Wet or waterlogged soil	Wet or waterlogged soil	Wet or waterlogged soil	Wet or waterlogged soil	Water	Water
A24/A2.A6.E6	C.2	Water	Water	Water	Wet or waterlogged soil	Wet or waterlogged soil	Wet or waterlogged soil	Wet or waterlogged soil	Wet or waterlogged soil	Wet or waterlogged soil	Wet or waterlogged soil	Water	Water
A24/A2.A5.E6	1150	Water	Water	Water	Water	Water	Water	Water	Water	Water	Water	Water	Water

Water	
Wet or waterlogged soil	
Dry (at the surface) soil	

Figure 2: LC Classes for IT4 “Le Cesine” test site- Seasonal Water Coverage



**Class: A11/A1.A7.A9.W8**

N°	<p><b>3-D LC/LU description/explanation/definition in terms of (3-D)appearance (visual, pictorial) properties in the 3-D world domain.</b></p> <p><b>Spatial units of measures: meters.</b></p> <p><b>Premise 1: vegetated classes are described by considering T1 as the time of presence of vegetation (or peak of biomass)</b></p> <p><b>Semantic net is composed of:</b></p> <ul style="list-style-type: none"> <li>• <b>Nodes (e.g. LCCS or GCH class, object composing the class)</b></li> <li>• <b>Edges (links, arcs), i.e. relations between objects</b> <ul style="list-style-type: none"> <li>○ <b>Non-spatial relationships: IS-A, PART-OF, DATA-OF, CON-OF</b></li> <li>○ <b>Spatial relationships</b> <ul style="list-style-type: none"> <li>▪ <b>Topological: ADJACENT, IN, CROSS, OVERLAP, DISJOINT</b></li> <li>▪ <b>Not topological:</b> <ul style="list-style-type: none"> <li>• <b>METRIC RELATIONS (distance in meters or very close, close, medium, far, very far)</b></li> <li>• <b>SPATIAL ORDER, CARDINAL RELATIONS</b></li> </ul> </li> </ul> </li> <li>○ <b>Temporal relationships</b></li> </ul> </li> <li>• <b>Attributes (class and edges): photometric, geometric, morphologic, texture</b></li> </ul>	<p><b>Description/explanation/definitions in terms of 2-D appearance (visual, pictorial) properties in the 2-D</b></p> <p><b>MIVIS data have been acquired on 24<sup>th</sup> May 2009 at the spatial resolution of 3 meters.</b></p> <p>NOTE: based on these 2-D class-specific pictorial properties an expert programmer should be able to write the source code of a class-specific rule-based classifier employing prior knowledge of the 3-D real world.</p>
<p>15</p>	<p><b>NODE: A11/A1.A7.A9.W8+Olea_europaea_groves</b></p> <p>Cultivated and managed terrestrial areas/Trees.Broad-leaved.Evergreen.Orchard</p> <p><b>+Environmental Attribute:</b></p> <ul style="list-style-type: none"> <li>• <b>WATER QUALITY:</b> no water</li> <li>• <b>CLIMATE:</b> no data</li> <li>• <b>LITHOLOGY:</b> no data</li> <li>• <b>SOIL SURFACE ASPECT:</b> no data</li> <li>• <b>SOIL SUBSURFACE ASPECT:</b> no data</li> </ul> <p><b>+Technical Attribute:</b> Olea europaea groves</p>	<p><b>Photometric:</b></p> <p><b>Summer(July-2005): QUICKBIRD (spatial resolution=2.4 m)</b></p> <ul style="list-style-type: none"> <li>○ <b>Foreground SIAM spectral categories. Tree crown :</b> 21 ASHRBR HNIR, 22 ASHRBR MNIR, 23 ASHRBR LNIR, 29 PB LSC</li> <li>○ <b>Background SIAM spectral categories. Soil:</b> 32 BBB_TNCL, 35 SBBNF_LSC, 38 ABBNF_LSC.</li> </ul>

## D5.2 VHR land cover maps

This class corresponds to one single habitat: Eunis: G2.91



Picture taken on September 2011

### Short habitat description:

Cultivated areas – fields with regular (geometric) shape, characterized by broad-leaved evergreen woody crops - height 2-4 m - trees spaced approximately 10 m, arranged in rows –

### **Summer(June-2009): QUICKBIRD (spatial resolution=2.4 m)**

- Foreground SIAM spectral categories. Tree crown : 22 ASHRBR MNIR, 23 ASHRBR LNIR, 24 ASHRBR VLNIR
- Background SIAM spectral categories. Soil: 32 BBB\_TNCL, 35 SBBNF\_LSC, 38 ABBNF\_LSC, 41 DBBNF\_LSC

### **Fall(October-2009): WORLDVIEW-2 (spatial resolution=2 m)**

- Foreground SIAM spectral categories. Tree crown : 17 SHV\_WEDR, 21 ASHRBR HNIR, 22 ASHRBR MNIR, 23 ASHRBR LNIR, 24 ASHRBR VLNIR
- Background SIAM spectral categories. Soil: 34 SBBF, 35 SBBNF\_LSC, 37 ABBF, 38 ABBNF\_LSC.

The patches are too small to obtain a representative MIVIS VNIR spectrum.

### Geometric attributes:

- Area:
- Perimeter:
- Length:
- Width:
- Shape:
- Position:
- Centroid:
- Angle:
- Compactness:
- Rectangularity:
- Elongation:
- Straightness of boundaries:
- List of skeleton endpoints with attributes: position, angle, inter-endpoint distance

### Morphological attributes:

## D5.2 VHR land cover maps

rows oriented in two directions, generally orthogonal.

Presence of an herbaceous layer (stratum), generally green from March to June, depending on farming practices, and/or bare soil (background).

### ***EDGES:***

#### **Non - spatial relationships:**

Class (**IS A**) Cultivated and managed terrestrial areas (**A11**)

#### Class **Foreground:**

- **T1 January-December:** Trees Broad-leaved (**PART-OF**) (height in [2 – 4] m)

#### Class **Background:**

- **T1\_1 March-June:**
  - herbaceous vegetation (depending on the agricultural practices) and bare soil (**PART-OF**)
  - shadow (depending on seasonality) (**PART-OF**)
- **T1\_2 July-February:**
  - bare soil (**PART-OF**)
  - shadow (depending on seasonality) (**PART-OF**)

**Spatial-non topological relations:** None (or not relevant)

#### **Spatial topological relations:**

- **Adjacent to:** A12/A2.A5.E7 (habitat E1.6) or A24/A2.A5.E7 (habitat 3170) or A24/A2.A6.E6 (habitat D5.1)

#### **Temporal relations:**

- **Class phenology:** Evergreen

#### **CLASS ATTRIBUTES:**

#### **Textural attributes:**

- **With Structure**
- With no Structure**

## D5.2 VHR land cover maps

**Cover:** from scattered to medium-high density

Class **Photometric/Phenological attributes:**

**Foreground:**

- **T1 January-December:** green

**Background:**

- **T1\_1 March-June:** brown-green
- **T1\_2 July-February:** brown

**Geometric attributes:**

**Foreground:**

- **Shape:** circular

**Morphological attributes:** regular fields

**Textural attributes:**

- ***Periodicity:*** equivalent to the tree-to-tree average distance: range [10m, 20 m]
- ***Oriented texture:*** generally oriented, but not always
- ***Number of directions:*** 2 generally orthogonal (but not always)

***EDGE ATTRIBUTES*** (if any):

**Additional info:** None (or not relevant)

**Conservation Status:** None (or not relevant)

## D5.2 VHR land cover maps

**Class: A11/A1.A8. A9.W7**

<p>16</p>	<p><b>NODE: A11/A1.A8.A9.W7+native_conifer_plantation</b></p> <p>Cultivated and managed terrestrial areas/Trees.Needleleaved.Evergreen.Plantation(coniferous reforestation)</p> <p><b>+Environmental Attribute:</b></p> <ul style="list-style-type: none"> <li>• <b>WATER QUALITY:</b> none</li> <li>• <b>CLIMATE:</b> none</li> <li>• <b>LITHOLOGY:</b> none</li> <li>• <b>SOIL SURFACE ASPECT:</b> none</li> <li>• <b>SOIL SUBSURFACE ASPECT:</b> none</li> </ul> <p><b>+Technical Attribute:</b> Native conifer plantations</p> <p>This class corresponds to one single habitat: Eunis: G3.F1</p> 	<p><b>Photometric:</b></p> <p><b>Summer(July-2005): QUICKBIRD (spatial resolution=2.4 m)</b></p> <ul style="list-style-type: none"> <li>○ <u>Foreground SIAM spectral categories.</u> <u>Tree crown</u> : 21 ASHRBR HNIR, 22 ASHRBR MNIR, 23 ASHRBR LNIR,</li> <li>○ <u>Background SIAM spectral categories.</u> Not significant.</li> </ul> <p><b>Summer(June-2009): QUICKBIRD (spatial resolution=2.4 m)</b></p> <ul style="list-style-type: none"> <li>○ <u>Foreground SIAM spectral categories.</u> <u>Tree crown</u> : 22 ASHRBR MNIR, 23 ASHRBR LNIR, 24 ASHRBR VLNIR</li> <li>○ <u>Background SIAM spectral categories.</u> Not significant</li> </ul> <p><b>Fall(October-2009): WORLDVIEW-2 (spatial resolution=2 m)</b></p> <ul style="list-style-type: none"> <li>○ <u>Foreground SIAM spectral categories:</u> <u>Tree crown</u> : 17 SHV_WEDR, 21 ASHRBR HNIR, 22 ASHRBR MNIR, 23 ASHRBR LNIR,24 ASHRBR VLNIR</li> <li>○ <u>Background SIAM spectral categories:</u>64 UN3_LSC</li> </ul>
-----------	--	---

Picture taken on September 2011



Picture taken on September 2011

**Short habitat description:**

Managed areas, plantations - fields with irregular shape, characterized by needle-leaved evergreen woody species in the tree layer - height 2-30 m – irregularly spaced trees (very old plantations with renovation).

Presence, throughout the year, of a broad-leaved evergreen shrub layer (background) characterized by sclerophyllous species (maquis).

**EDGES:**

**Non - spatial relationships:**

Class (**IS A**) Cultivated and managed terrestrial areas (**A11**)

Class **Foreground:**

- **T1 January-December:** Trees Needleleaved (**PART-OF**) (height in [2 – 30] m)

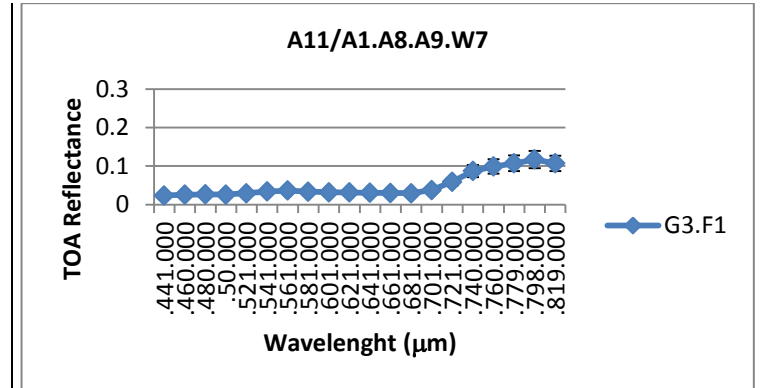

MIVIS VNIR Spectrum acquired on 24<sup>th</sup> May 2009  
(spatial resolution =3m)

**Geometric attributes:**

- **Area:**
- **Perimeter:**
- **Length:**
- **Width:**
- **Shape:**
- **Position:**
- **Centroid:**
- **Angle:**
- **Compactness:**
- **Rectangularity:**
- **Elongation:**
- **Straightness of boundaries:**
- **List of skeleton endpoints with attributes: position, angle, inter-endpoint distance**

**Morphological attributes:**

## D5.2 VHR land cover maps

### Class **Background:**

- **T1 January-December:**
  - shrub A12/A1.A4.D1.E1 (habitat F5.514) (**PART-OF**)
  - shadow (depending on seasonality) (**PART-OF**)

**Spatial-non topological relations:** None (or not relevant)

### **Spatial topological relations:**

- **Adjacent to:** A12/A1.A4.D1.E1 (habitat F6.2C or 5330 or F5.514) or A24/A2.A6.E6 (habitat D5.1)

### **Temporal relations:**

- **Class phenology:** Evergreen

### **CLASS ATTRIBUTES:**

**Cover:** from scattered to medium-high

### Class **Photometric/Phenological attributes:**

#### **Foreground:**

- **T1 January-December:** dark green

#### **Background:**

- **T1 January-December:** green

### **Geometric attributes:**

- **Shape:** irregular fields

**Morphological attributes:** none (or not relevant)

### **Textural attributes:**

### **Textural attributes:**

- **With Structure**
- **With no Structure**



## D5.2 VHR land cover maps

*Non structured texture*

- **Periodicity:** irregular distance among the trees
- **Oriented texture:** not oriented
- **Number of directions:** none

**EDGE ATTRIBUTES** (if any):

**Additional info:** None (or not relevant)

**Conservation Status:** due to frequent fires, the number of young plants of pine is going up for the last decade

**Class: A11/A3.A5**

<p>14</p>	<p><b>NODE: A11/A3.A5+no_graminoid_crops</b></p> <p>Cultivated and managed terrestrial areas/Herbaceous.NonGraminoid</p> <p><b>+Environmental Attribute:</b></p> <ul style="list-style-type: none"> <li>• <b>WATER QUALITY:</b> none</li> <li>• <b>CLIMATE:</b> none</li> <li>• <b>LITHOLOGY:</b> none</li> <li>• <b>SOIL SURFACE ASPECT:</b> none</li> <li>• <b>SOIL SUBSURFACE ASPECT:</b> none</li> </ul> <p><b>+Technical Attribute:</b> no graminoid crops</p> <p>This class corresponds to one single habitat: Eunis: I1.3</p> <p><b><u>Short habitat description:</u></b></p> <p>Cultivated areas – fields with regular (geometric) shape, characterized by herbaceous non graminoid crops, usually vegetables with vegetative cycle (green plants) from April to July and withered/dry plants (brown-yellowish) from July to September-October- plants spaced m, arranged in rows – rows oriented in one direction.</p> <p>Presence of soil as background. Soil becomes foreground from October to March (except any winter crops).</p> <p><b><u>EDGES:</u></b></p> <p><b><u>Non - spatial relationships:</u></b></p> <p>Class (<b>IS A</b>) Cultivated and managed terrestrial areas (<b>A11</b>)</p> <p>Class <b>Foreground:</b></p> <ul style="list-style-type: none"> <li>• <b>T1 April-July:</b> Herbaceous Non Graminoid (<b>PART-OF</b>) (height in [0,5-1] m)</li> <li>• <b>T2 August-March:</b> withered/dry plants or tilled soil</li> </ul>	<p><b><i>Photometric:</i></b></p> <p><b>Summer(July-2005): QUICKBIRD (spatial resolution=2.4 m)</b></p> <ul style="list-style-type: none"> <li>○ <u>Foreground SIAM spectral categories.</u> <u>Vegetation</u> : 9 AVVHNIR, 21 ASHRBR HNIR, 22 ASHRBR MNIR, 29 PB LSC</li> <li>○ <u>Background SIAM spectral categories.</u> <u>Soil:</u>32 BBB_TNCL , 34 SBBF, 35 SBBNF_LSC, 38 ABBNF_LSC</li> </ul> <p><b>Summer(June-2009): QUICKBIRD (spatial resolution=2.4 m)</b></p> <ul style="list-style-type: none"> <li>○ <u>Foreground SIAM spectral categories.</u> <u>Vegetation:</u> 21 ASHRBR HNIR, 22 ASHRBR MNIR, 23 ASHRBR LNIR, 29 PB LSC</li> <li>○ <u>Background SIAM spectral categories.</u> <u>Soil:</u> 32 BBB_TNCL, 35 SBBNF_LSC, 38 ABBNF_LSC.</li> </ul> <p><b>Fall(October-2009): WORLDVIEW-2 (spatial resolution=2 m)</b></p> <ul style="list-style-type: none"> <li>○ <u>Foreground SIAM spectral categories.</u> <u>Vegetation</u> : 21 ASHRBR HNIR, 22 ASHRBR MNIR, 23 ASHRBR LNIR</li> <li>○ <u>Background SIAM spectral categories.</u> <u>Soil:</u> 34 SBBF, 35 SBBNF_LSC, 36 ABBVF, 37 ABBF, 38 ABBNF_LSC, 62 SN_CL_BBB_LSC</li> </ul> <p>The patches are too small to obtain a representative MIVIS VNIR spectrum.</p> <p><b><u>Geometric attributes:</u></b></p> <ul style="list-style-type: none"> <li>• <b>Area:</b></li> <li>• <b>Perimeter:</b></li> <li>• <b>Length:</b></li> </ul>
-----------	--	--

## D5.2 VHR land cover maps

### Class **Background**:

- **T1 April-July:** soil (**PART-OF**)
- **T2 August-March:** soil or background coincides with Foreground

**Spatial-non topological relations:** None (or not relevant)

### **Spatial topological relations:**

- **Adjacent to:** A12/A2.A5.E7 (habitat E1.6) or A24/A2.A5.E7 (habitat 3170) or A24/A2.A6.E6 (habitat D5.1 or C2)

### **Temporal relations:**

- **Class phenology:** see Figure 1

### **CLASS ATTRIBUTES:**

**Cover:** from scattered to medium-high

### Class **Photometric/Phenological attributes:**

- **T1 April-July:** green
- **T2 Aug-March:** yellow, yellow/green or brown (soil)

### **Geometric attributes:**

- **Shape:** regular fields

**Morphological attributes:** none (or not relevant)

### **Textural attributes:**

- **Periodicity:** regular distance among the plants (10 to 40 cm)
- **Oriented texture:** oriented
- **Number of directions:** 1

**EDGE ATTRIBUTES** (if any):

- **Width:**
- **Shape:**
- **Position:**
- **Centroid:**
- **Angle:**
- **Compactness:**
- **Rectangularity:**
- **Elongation:**
- **Straightness of boundaries:**
- **List of skeleton endpoints with attributes:** position, angle, inter-endpoint distance

### **Morphological attributes:**

### **Textural attributes:**

- **With Structure**
- **With no Structure**

D5.2 VHR land cover maps

**Additional info:** None (or not relevant)

**Conservation Status:** None (or not relevant)

**Class: A12/A2.A5.E7**

<p>1</p>	<p><b>NODE:A12/A2.A5.E7+O3.M233.N12-AC+annuals_of_Stellarietea_mediae</b></p> <p>Natural and semi-natural terrestrial vegetation/Herbaceous.Forbs.Annual</p> <p><b>+Environmental Attribute:</b></p> <ul style="list-style-type: none"> <li>• <b>WATER QUALITY:</b> none</li> <li>• <b>CLIMATE:</b> Subtropics-Winter Rainfall (O3)</li> <li>• <b>LITHOLOGY:</b> Calcareous rock-calcarenite (M233)</li> <li>• <b>SOIL SURFACE ASPECT:</b> none</li> <li>• <b>SOIL SUBSURFACE ASPECT:</b> Acrisol (N12-AC)</li> </ul> <p><b>+Technical Attribute:</b> Annuals of Stellarietea mediae</p> <p>This class corresponds to the habitat: Eunis E1.6</p> <p><b><u>Short habitat description:</u></b></p> <p>Terrestrial natural areas – herbaceous annual vegetation of non graminoid plants with vegetative cycle (green plants) from (March) April to June, than becoming withered/dry (brown-yellowish)</p> <p>Medium density (medium-high cover).</p> <p>Usually adjacent to cultivated field (mostly because these areas are abandoned fields and/or fallow lands) or to habitat F6.2C or D5.1. Usually regular (geometric) shape.</p> <p>Presence of soil as background. Soil becomes foreground in winter.</p> <p><b>EDGES:</b></p> <p><b><u>Non - spatial relationships:</u></b></p> <p>Class (IS A) Natural and semi-natural terrestrial vegetation (A12)</p> <p>Class <b>Foreground:</b></p> <ul style="list-style-type: none"> <li>• <b>T1 March- June:</b> herbaceous forbs (PART-OF) (height in [0.3 –0.8] m)</li> <li>• <b>T2 July - September:</b> withered/dry plants in summer (PART OF)</li> </ul>	<p><b>Photometric:</b></p> <p><b>Summer(July-2005): QUICKBIRD (spatial resolution=2.4 m)</b></p> <ul style="list-style-type: none"> <li>○ <u>Foreground SIAM spectral categories.</u> <u>Vegetation</u> : 21 ASHRBR HNIR, 22 ASHRBR MNIR, 23 ASHRBR LNIR, 29 PB LSC</li> <li>○ <u>Background SIAM spectral categories.</u> <u>Soil:</u>32 BBB_TNCL , 33 SBBVF_LSC, 35 SBBNF_LSC, 38 ABBNF_LSC, 39 DBBVF, 62 SN_CL_BBB_LSC</li> </ul> <p><b>Summer(June- 2009):QUICKBIRD (spatial resolution=2.4 m)</b></p> <ul style="list-style-type: none"> <li>○ <u>Foreground SIAM spectral categories.</u> <u>Vegetation:</u> 21 ASHRBR HNIR, 22 ASHRBR MNIR, 23 ASHRBR LNIR, 24 ASHRBR VLNIR</li> <li>○ <u>Background SIAM spectral categories:</u> <ul style="list-style-type: none"> <li>○ <u>Soil:</u>33 SBBVF_LSC, 35 SBBNF_LSC, 36 ABBVF, 38 ABBNF_LSC, 39 DBBVF, 62 SN_CL_BBB_LSC</li> <li>○ <u>Water:</u> 52 TWASH_LSC</li> </ul> </li> </ul> <p><b>Fall(October-2009):WORLDVIEW-2 (spatial resolution=2 m)</b></p> <ul style="list-style-type: none"> <li>○ <u>Foreground SIAM spectral categories.</u> <u>Vegetation</u> : 21 ASHRBR HNIR, 22 ASHRBR MNIR, 23 ASHRBR LNIR, 24 ASHRBR VLNIR</li> <li>○ <u>Background SIAM spectral categories:</u> <ul style="list-style-type: none"> <li>○ <u>Soil:</u>34 SBBF, 35 SBBNF_LSC, 36 ABBVF, 38 ABBNF_LSC, 39 DBBVF, 62 SN_CL_BBB_LSC</li> <li>○ <u>Water:</u> 50 DPWASH_LSC, 52 TWASH_LSC</li> </ul> </li> </ul>
----------	---	---

- **T3 October - February:** soil (**PART OF**)

**Class Background:**

- **T1 March -June:** soil (**PART-OF**)
- **T2 July- September:** soil (**PART-OF**)
- **T3 October - February:** Background coincides with Foreground (**PART OF**)

**Spatial-non topological relations:** None (or not relevant)

**Spatial topological relations:**

- **Adjacent to:** A11/A1.A7.A9.W8 (habitat G2.91) or A12/A1.A4.D1.E1 (habitat F6.2C) or A24/A2.A6.E6 (habitat D5.1) or A11/A3.A5 (habitat I1.3)

**Temporal relations:**

- **Class phenology:** Annual

**CLASS ATTRIBUTES:**

**Cover:** closed (> 65%) to open (65-50%), medium-high density

**Class Photometric/Phenological attributes:**

- **T1 April-June:** green
- **T3 July- September:** yellow
- **T4 September-March:** brown (soil)

**Geometric attributes:** None (or not relevant)

**Morphological attributes:** None (or not relevant)

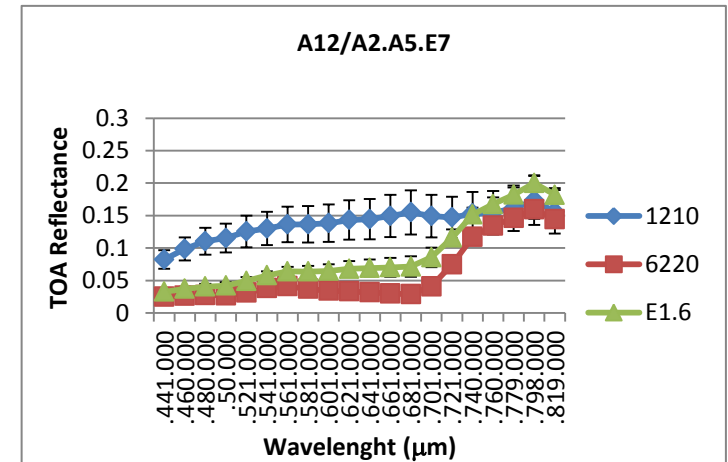

MIVIS VNIR Spectrum acquired on 24<sup>th</sup> May 2009  
(spatial resolution =3m)

**Geometric attributes:**

- **Area:**
- **Perimeter:**
- **Length:**
- **Width:**
- **Shape:**
- **Position:**
- **Centroid:**
- **Angle:**
- **Compactness:**

**Textural attributes:** None (or not relevant)

***EDGE ATTRIBUTES*** (if any):

**Additional info:** None (or not relevant)

**Conservation Status:** None (or not relevant)

-----

***NODE:A12/A2.A5.E7+O3.M233.N3.N12-AR+Cakile\_maritima***

Natural and semi-natural terrestrial vegetation/Herbaceous.Forbs.Annual

**+Environmental Attribute:**

- **WATER QUALITY:** none
- **CLIMATE:** Subtropics-Winter Rainfall (**O3**)
- **LITHOLOGY:** Calcareous rock-calcarenite (**M233**)
- **SOIL SURFACE ASPECT:** Loose and shifting sands (**N3**)
- **SOIL SUBSURFACE ASPECT:** Arenosols (**N12-AR**)

**+Technical Attribute:** Cakile maritima

6

This class corresponds to the habitat: 1210

- **Rectangularity:**
- **Elongation:**
- **Straightness of boundaries:**
- **List of skeleton endpoints with attributes: position, angle, inter-endpoint distance**

**Morphological attributes:**

**Textural attributes:**

- **With Structure**
- **With no Structure**

D5.2 VHR land cover maps



**Picture taken on June 2007**



**Picture taken on June 2007**

**Short habitat description:**



## D5.2 VHR land cover maps

Terrestrial natural areas – herbaceous annual vegetation of non graminoid plants with vegetative cycle (green plants) from April (May) to August.

This is the first vegetated area, along the sandy shores, next to the coast-line and forming a strip parallel to the coastline.

Low density (low-medium cover)

Adjacent to the tidal zone towards the sea, and adjacent to the habitat 2110 (A12/A2.A6.E6) towards the inland.

Sandy shores – sand (background).

### ***EDGES:***

#### **Non - spatial relationships:**

Class (*IS A*) Natural and semi-natural terrestrial vegetation (**A12**)

#### Class **Foreground:**

- **T1 April- September:** herbaceous forbs (**PART-OF**) (height in [0,01–0,3]m)
- **T2 October-March:** sand, washed by waves during storms (**PART OF**)

#### Class **Background:**

- **T1 April- September:** sand (**PART-OF**)
- **T2 October-March:** Background coincides with Foreground

**Spatial-non topological relations:** None (or not relevant)

#### **Spatial topological relations:**

- **Adjacent to:**
  - **Towards the sea:** sandy shore
  - **On the other side (towards the inland part):** A12/A2.A6.E6 (habitat 2110)

#### **Temporal relations:**

- **Class phenology:** Annual

**CLASS ATTRIBUTES:**

**Cover:** open (40-(20-10)%)

Class **Photometric/Phenological attributes:**

- **T1 April- September:** green
- **T2 October - March:** grey-brown (sand)

**Geometric attributes:** None (or not relevant)

**Morphological attributes:** None (or not relevant)

**Textural attributes:** None (or not relevant)

**EDGE ATTRIBUTES** (if any):

**Additional info:** None (or not relevant)

**Conservation Status:** None (or not relevant)

-----

**NODE:**A12/A2.A5.E7+O3.M233.N6.N12-LP+annuals\_of\_Tuberarietea

Natural and semi-natural terrestrial vegetation/Herbaceous.Forbs.Annual

**+Environmental Attribute:**

- **WATER QUALITY:** none
- **CLIMATE:** Subtropics-Winter Rainfall (**O3**)
- **LITHOLOGY:** Calcareous rock-calcarenite (**M233**)

## D5.2 VHR land cover maps

- **SOIL SURFACE ASPECT:** Soil surface, very stony (40-80%) (**N6**)
- **SOIL SUBSURFACE ASPECT:** Leptosol (**N12-LP**)

+**Technical Attribute:** Annuals of Tuberarietea

This class corresponds to the habitat: 6220

### **Short habitat description:**

Terrestrial natural areas – herbaceous annual vegetation of non graminoid plants with vegetative cycle (green plants) from March to May (June).

Low density (low-medium cover).

In contact (adjacent) to dwarf shrub vegetation (garrigue) of habitat F6.2C(A12/A1.A4.D1.E1) or to broad-leaved evergreen medium-high shrub vegetation (maquis) of habitat 5330 (A12/A1.A4.D1.E1).

Presence of outcropping of calcareous rocks (background)

Small patches

### ***EDGES:***

8(8.2)

### **Non - spatial relationships:**

Class (**IS A**) Natural and semi-natural terrestrial vegetation (**A12**)

### Class **Foreground:**

- **T1 March- May:** herbaceous forbs (**PART-OF**) (height in [0,03 – 0,2] m)
- **T2 June-February:** calcareous rock with bare rock and withered/dry in summer (**PART OF**)

### Class **Background:**

- **T1 March-May:** calcareous rock with bare rock (**PART-OF**)
- **T2 June-February:** Background coincides with Foreground

**Spatial-non topological relations:** None (or not relevant)

## D5.2 VHR land cover maps

### **Spatial topological relations:**

- **Adjacent to:** A12/A1.A4.D1.E1 (habitat F6.2C) or less frequently A12/A1.A4.D1.E1 (habitat 5330)

### **Temporal relations:**

- **Class phenology:** Annual

### **CLASS ATTRIBUTES:**

**Cover:** open (40-(20-10)%)

### Class **Photometric/Phenological attributes:**

- **T1 March-May:** green
- **T2 June-February:** bright yellow

### **Geometric attributes:**

- **Shape:** small irregular patches

**Morphological attributes:** None (or not relevant)

**Textural attributes:** None (or not relevant)

**EDGE ATTRIBUTES** (if any):

**Additional info:** None (or not relevant)

**Conservation Status:** None (or not relevant)

D5.2 VHR land cover maps

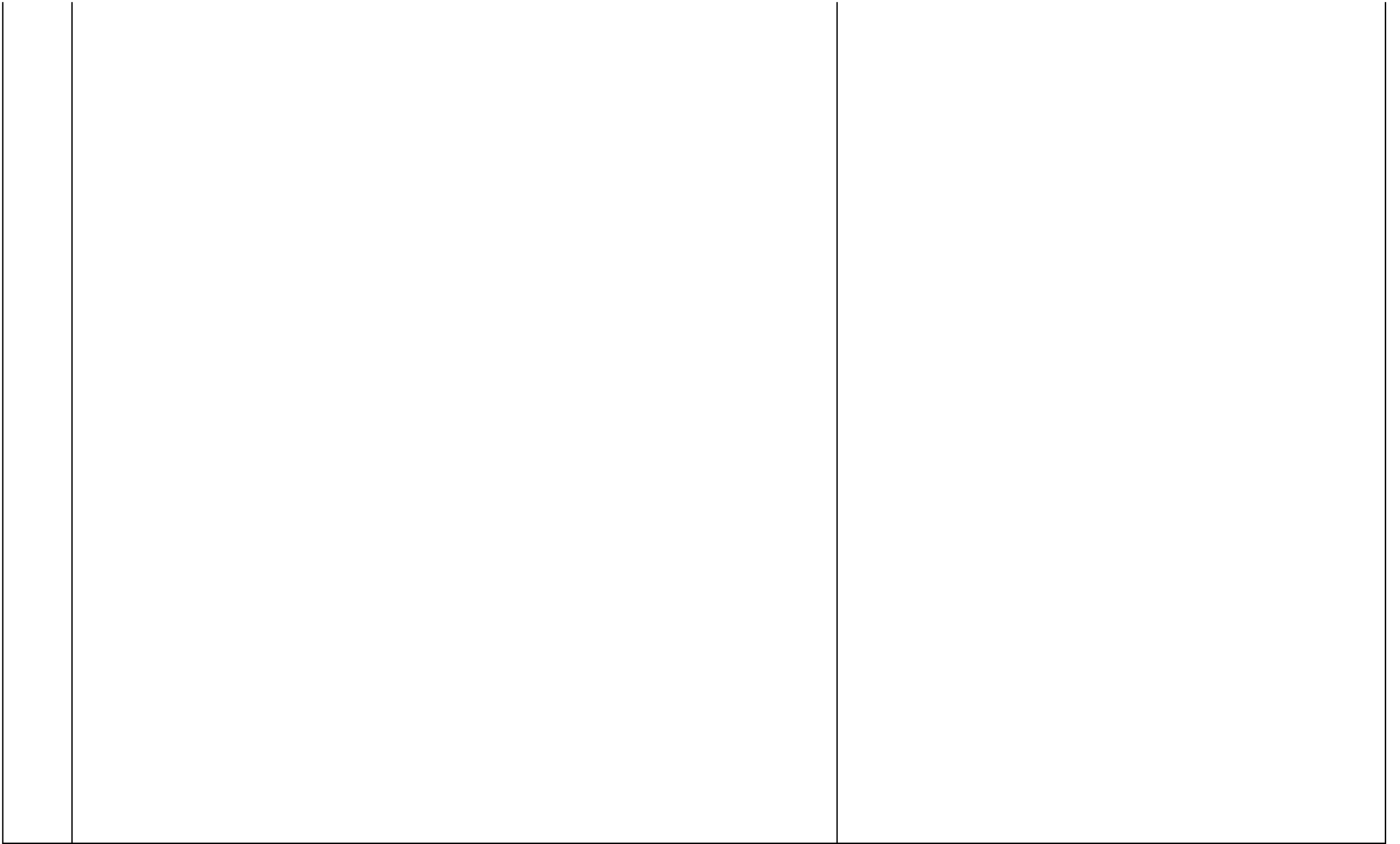

**Class: A12/A1.A4.D1.E2**

2	<p><b>NODE: A12/A1.A4.D1.E2+O3.M233.N12-LP+rubus_spp</b></p> <p>Natural and semi-natural terrestrial vegetation/Woody.Shrubs.Broad-leaved.Deciduous  <b>+Environmental Attribute:</b></p> <ul style="list-style-type: none"> <li>• <b>WATER QUALITY:</b> none</li> <li>• <b>CLIMATE:</b> Subtropics-Winter Rainfall (O3)</li> <li>• <b>LITHOLOGY:</b> Calcareous rock-calcarenite (M233)</li> <li>• <b>SOIL SURFACE ASPECT:</b> none</li> <li>• <b>SOIL SUBSURFACE ASPECT:</b> Leptosol (N12-LP)</li> </ul> <p><b>+Technical Attribute:</b> Rubus spp.</p> <p>This class corresponds to one single habitat: Eunis F5.51</p> <p><b><u>Short habitat description:</u></b></p> <p>Terrestrial natural areas –woody vegetation characterized by a lower layer of broad-leaved evergreen (not sclerophyllous) shrubs and an upper layer of broad-leaved deciduous low trees (or high shrubs) - height 1.5 - 2 m.</p> <p>This vegetation shows a peak of biomass in summer (April-October, intense green) and a less biomass in winter (with a brown-yellowish green, or less intense green).</p> <p>Linear elements adjacent to ditches or drainage canals (streams of water) or more rarely adjacent to tracks along the inner wetlands.</p> <p>High density (very high cover).</p>	<p><b>Photometric:</b></p> <p><b>Summer(July-2005): QUICKBIRD (spatial resolution=2.4 m)</b></p> <ul style="list-style-type: none"> <li>○ <u>Foreground SIAM spectral categories.</u> <u>Tree crown</u> : 9              AVVHNIR, 21 ASHRBR HNIR, 22 ASHRBR MNIR, 29 PB LSC</li> <li>○ <u>Background SIAM spectral categories.</u> Not significant.</li> </ul> <p><b>Summer(June-2009):QUICKBIRD (spatial resolution=2.4 m)</b></p> <ul style="list-style-type: none"> <li>○ <u>Foreground SIAM spectral categories.</u> <u>Tree crown</u> : 3              SVVHNIR, 4 SVHNIR, 21 ASHRBR HNIR, 22 ASHRBR MNIR, 23 ASHRBR LNIR</li> <li>○ <u>Background SIAM spectral categories.</u> Not significant.</li> </ul> <p><b>Fall(October-2009):WORLDVIEW-2 (spatial resolution=2 m)</b></p> <ul style="list-style-type: none"> <li>○ <u>Foreground SIAM spectral categories.</u> <u>Tree crown</u> : 21 ASHRBR              HNIR, 22 ASHRBR MNIR, 23 ASHRBR LNIR</li> <li>○ <u>Background SIAM spectral categories.</u> Not significant.</li> </ul>
---	---	--

## D5.2 VHR land cover maps

Presence of evergreen bushes (brambles) as background.

### **EDGES:**

#### **Non - spatial relationships:**

Class (**IS A**) Natural and semi-natural terrestrial vegetation (**A12**)

#### Class **Foreground:**

- **T1 April-October:** Woody Shrubs Broad-leaved (**PART-OF**) (height in [1.5 – 2]m)
- **T2 November-March:** evergreen bushes (**PART OF**)

#### Class **Background:**

- **T1 April-October:** evergreen bushes (**PART-OF**)
- **T2 November-March:** Background coincides with Foreground

**Spatial-non topological relations:** None (or not relevant)

#### **Spatial topological relations:**

- **Adjacent to:** A24/A2.A6.E6 (habitat C2)

#### **Temporal relations:**

- **Class phenology:** Deciduous

#### **CLASS ATTRIBUTES:**

**Cover:** high density (80-100%)

#### Class **Photometric/Phenological attributes:**

- **T1 April-October:** green
- **T2 November-March:** green – yellow/green

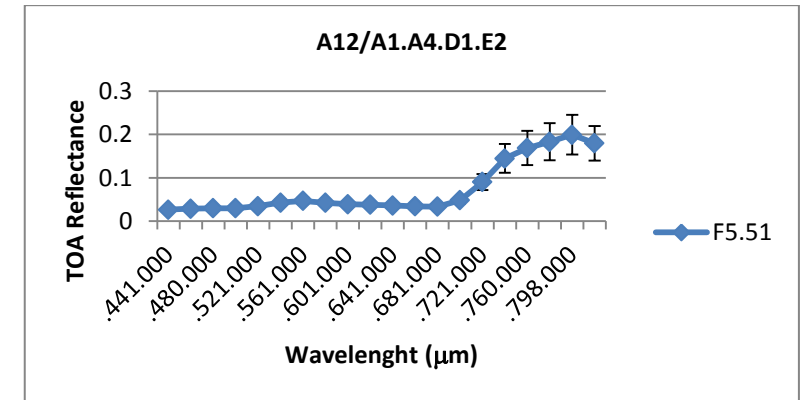

MIVIS VNIR Spectrum acquired on 24<sup>th</sup> May 2009

(spatial resolution =3m)

#### **Geometric attributes:**

- **Area:**
- **Perimeter:**
- **Length:**
- **Width:**
- **Shape:**
- **Position:**
- **Centroid:**
- **Angle:**
- **Compactness:**
- **Rectangularity:**
- **Elongation:**
- **Straightness of boundaries:**
- **List of skeleton endpoints with attributes: position, angle, inter-endpoint distance**

#### **Morphological attributes:**

#### **Textural attributes:**

## D5.2 VHR land cover maps

### **Geometric attributes:**

- **Shape:** Linear
- **Position:** parallel to ditches or drainage canals or less frequently parallel to the tracks close to wet areas

**Morphological attributes:** None (or not relevant)

**Textural attributes:** None (or not relevant)

***EDGE ATTRIBUTES*** (if any):

**Additional info:** None (or not relevant)

**Conservation Status:** None (or not relevant)

- **With Structure**
- **With no Structure**



**Class: A12/A1.A4.D2.E1**

<p>3</p>	<p><b>NODE:A12/A1.A4.D2.E1+O3.M213.N12-AR+Juniperus_macrocarpa</b></p> <p>Natural and semi-natural terrestrial vegetation/Woody.Shrubs.Needle-leaved.Evergreen</p> <p><b>+Environmental Attribute:</b></p> <ul style="list-style-type: none"> <li>• <b>WATER QUALITY:</b> none</li> <li>• <b>CLIMATE:</b> Subtropics-Winter Rainfall (O3)</li> <li>• <b>LITHOLOGY:</b> Unconsolidated-clastic sedimentary rock-sand(M213)</li> <li>• <b>SOIL SURFACE ASPECT:</b> none</li> <li>• <b>SOIL SUBSURFACE ASPECT:</b> Arenosols (N12-AR)</li> </ul> <p><b>+Technical Attribute:</b> Juniperus macrocarpa</p> <p>This class corresponds to the habitat: 2250</p> <p><b><u>Short habitat description:</u></b></p> <p>Terrestrial natural areas – woody vegetation characterized by needle-leaved evergreen shrubs – height 1,5-2m.</p> <p>Distributed along the sandy shores, usually forming a strip (width &gt; 2 m) parallel to the coastline. In this specific case (coastal erosion and habitat fragmentation), this habitat is present in a few patches distributed parallel to the coastline.</p> <p>Adjacent to habitat 2110 (A12/A2.A6.E6) towards the sea, and adjacent to habitat 5330 (A12/A1.A4.D1.E1) or to 1410 (A24/A2.A6.E6) towards the inland.</p> <p>High density (high cover)</p> <p>Sandy shores – sand (background).</p> <p><b><u>EDGES:</u></b></p> <p><b><u>Non - spatial relationships:</u></b></p> <p>Class (IS A) Natural and semi-natural terrestrial vegetation (A12)</p>	<p><b>Photometric:</b></p> <p><b>Summer(July-2005): QUICKBIRD (spatial resolution=2.4 m)</b></p> <ul style="list-style-type: none"> <li>○ <u>Foreground SIAM spectral categories.</u> <u>Tree crown</u> : 21 ASHRBR HNIR, 22 ASHRBR MNIR, 29 PB LSC</li> <li>○ <u>Background SIAM spectral categories.</u> <u>Soil:</u> 34 SBBF, 35 SBBNF_LSC, 36 ABBVF, 38 ABBNF_LSC, 62 SN_CL_BBB_LSC</li> </ul> <p><b>Summer(June- 2009):QUICKBIRD (spatial resolution=2.4 m)</b></p> <ul style="list-style-type: none"> <li>○ <u>Foreground SIAM spectral categories.</u> <u>Tree crown</u> : 21 ASHRBR HNIR, 22 ASHRBR MNIR, 23 ASHRBR LNIR</li> <li>○ <u>Background SIAM spectral categories.</u> <ul style="list-style-type: none"> <li>○ <u>Soil:</u> 33 SBBVF_LSC, 35 SBBNF_LSC, 36 ABBVF, 38 ABBNF_LSC, 62 SN_CL_BBB_LSC</li> <li>○ <u>Water:</u> 50 DPWASH_LSC</li> </ul> </li> </ul> <p><b>Fall(October-2009):WORLDVIEW-2 (spatial resolution=2 m)</b></p> <ul style="list-style-type: none"> <li>○ <u>Foreground SIAM spectral categories.</u> <u>Tree crown</u> : 21 ASHRBR HNIR, 22 ASHRBR MNIR, 23 ASHRBR LNIR</li> <li>○ <u>Background SIAM spectral categories.</u> <ul style="list-style-type: none"> <li>○ <u>Soil:</u> 35 SBBNF_LSC, 36 ABBVF, 38 ABBNF_LSC, 39 DBBVF</li> <li>○ <u>Water:</u> 52 TWASH_LSC</li> </ul> </li> </ul>
----------	---	---

## D5.2 VHR land cover maps

### Class **Foreground:**

- **T1 January-December:** Woody Shrubs Needle-leaved (**PART-OF**) (height in [1.5 – 2]m)

### Class **Background:**

- **T1 January-December:** sand (**PART-OF**)

**Spatial-non topological relations:** None (or not relevant)

### **Spatial topological relations:**

- **Adjacent:**
  - **Towards the sea:** A12/A2.A6.E6 (habitat 2110);
  - **On the other side:** A12/A1.A4.D1.E1 (habitat 5330) or A24/A2.A6.E6 (habitat 1410)

### **Temporal relations:**

- **Class phenology:** Evergreen

### **CLASS ATTRIBUTES:**

**Cover:** high density (80-100%)

### Class **Photometric/Phenological attributes:**

- **T1 January-December:** green

### **Geometric attributes:**

- **Width:** > 2 m

**Morphological attributes:** Woody Shrubs growing sparsely distributed parallel to coastline\_

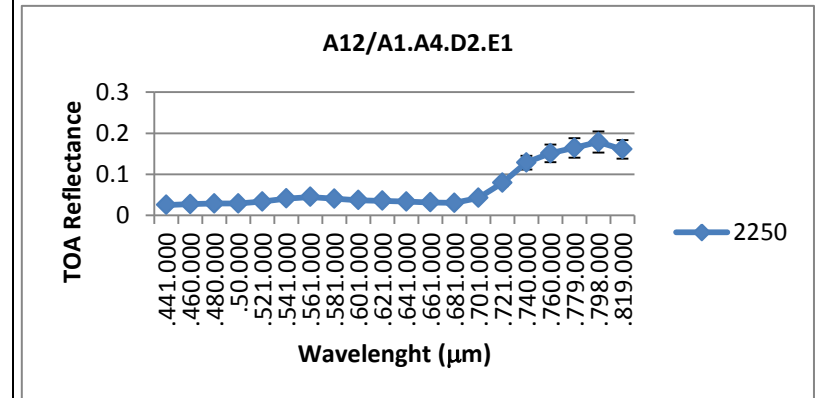

*MIVIS VNIR Spectrum acquired on 24<sup>th</sup> May 2009  
(spatial resolution =3m)*

### **Geometric attributes:**

- **Area:**
- **Perimeter:**
- **Length:**
- **Width:**
- **Shape:**
- **Position:**
- **Centroid:**
- **Angle:**
- **Compactness:**
- **Rectangularity:**
- **Elongation:**
- **Straightness of boundaries:**
- **List of skeleton endpoints with attributes: position, angle, inter-endpoint distance**

D5.2 VHR land cover maps

**Textural attributes:** None (or not relevant)

***EDGE ATTRIBUTES*** (if any):

**Additional info:** None (or not relevant)

**Conservation Status:** high fragmentation

**Morphological attributes:**

**Textural attributes:**

- **With Structure**
- **With no Structure**

**Class: A12/A1.A4.D1.E1**

4	<p><b>NODE:A12/A1.A4.D1.E1+O3.M213.N12-AR+Erica_forskalii</b></p> <p>Natural and semi-natural terrestrial vegetation/Woody.Shrubs.Broad-leaved.Evergreen</p> <p><b>+Environmental Attribute:</b></p> <ul style="list-style-type: none"> <li>• <b>WATER QUALITY:</b> none</li> <li>• <b>CLIMATE:</b> Subtropics-Winter Rainfall (O3)</li> <li>• <b>LITHOLOGY:</b> Calcareous rock-calcarenite(M233)</li> <li>• <b>SOIL SURFACE ASPECT:</b> Soil surface, stony (5-40%) (N5)</li> <li>• <b>SOIL SUBSURFACE ASPECT:</b> Leptosols (N12-LP)</li> </ul> <p><b>+Technical Attribute:</b> Erica forskalii</p> <p>This class corresponds to the habitat: Eunis F6.2C</p> <p><b><u>Short habitat description:</u></b></p> <p>Terrestrial natural areas – woody vegetation characterized by broad-leaved evergreen dwarf shrubs –low cover (unevenly distributed on the surface, leaving open areas of shallow soils and outcropping rocks) - height 0,5-0,8 m</p> <p>Presence of shallow soils and outcropping rocks as background.</p> <p>Adjacent to habitat 6220, or to E1.6, or to G3.F1 or to F5.514.</p> <p>Distributed in inland areas, not next to the coastline, in correspondence of calcareous geological substrata.</p> <p><b>EDGES:</b></p> <p><b><u>Non - spatial relationships:</u></b></p> <p>Class (IS A) Natural and semi-natural terrestrial vegetation (A12)</p> <p>Class <b>Foreground:</b></p> <ul style="list-style-type: none"> <li>• <b>T1 January-December:</b> Woody Shrubs Broad-leaved (PART-OF) (height in [0.4 – 0.7] m)</li> </ul>	<p><b>Photometric:</b></p> <p><b>Summer(July-2005): QUICKBIRD (spatial resolution=2.4 m)</b></p> <ul style="list-style-type: none"> <li>○ <u>Foreground SIAM spectral categories.</u> <u>Tree crown</u> : 4 SVHNIR, 21 ASHRBR HNIR, 22 ASHRBR MNIR, 23 ASHRBR LNIR</li> <li>○ <u>Background SIAM spectral categories.</u> <u>Soil:</u> 35 SBBNF_LSC</li> </ul> <p><b>Summer(June- 2009):QUICKBIRD (spatial resolution=2.4 m)</b></p> <ul style="list-style-type: none"> <li>○ <u>Foreground SIAM spectral categories.</u> <u>Tree crown</u> : 4 SVHNIR, 5 SVMNIR, 22 ASHRBR MNIR, 23 ASHRBR LNIR</li> <li>○ <u>Background SIAM spectral categories.</u> <u>Water:</u> 50 DPWASH_LSC</li> </ul> <p><b>Fall(October-2009):WORLDVIEW-2 (spatial resolution=2 m)</b></p> <ul style="list-style-type: none"> <li>○ <u>Foreground SIAM spectral categories.</u> <u>Tree crown</u> : 4 SVHNIR, 21 ASHRBR HNIR, 22 ASHRBR MNIR, 23 ASHRBR LNIR, 24 ASHRBR VLNIR</li> <li>○ <u>Background SIAM spectral categories.</u> Not significant</li> </ul>
---	---	---

**Class Background:**

- **T1 January-December:** calcareous rock (**PART-OF**)

**Spatial-non topological relations:**

- short/dwarf shrubs growing far from (> 50 m) coastline

**Spatial topological relations:**

- **Adjacent to:** A12/A2.A5.E7 (habitat E1.6) or A12/A2.A5.E7 (habitat 6220) or A11/A1.A8.A9.W7 (habitat G3.F1) or A12/A1.A4.D1.E1 (habitat F5.514)

**Temporal relations:**

- **Class phenology:** Evergreen

**CLASS ATTRIBUTES:**

**Cover:** closed (> 65%) to open (65-50%), medium-high density

**Class Photometric/Phenological attributes:**

- **T1 January-December:** green (with a peak of biomass in April-July)

**Geometric attributes:** None (or not relevant)

**Morphological attributes:** None (or not relevant)

**Textural attributes:** None (or not relevant)

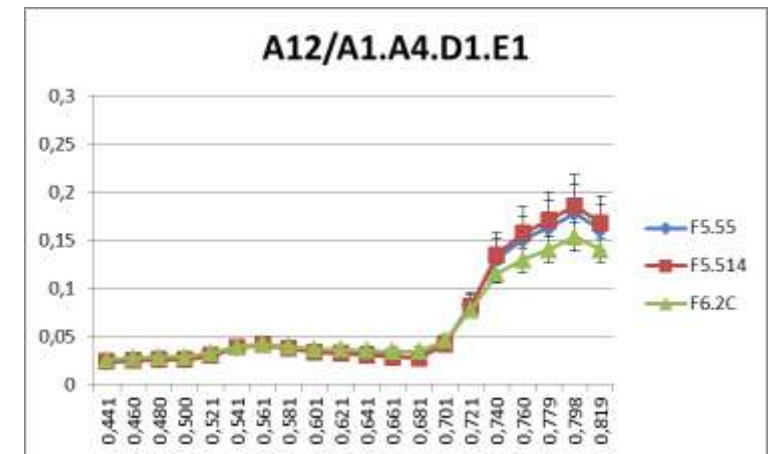

*MIVIS VNIR Spectrum acquired on 24<sup>th</sup> May 2009*

*(spatial resolution =3m)*

**Geometric attributes:**

- **Area:**
- **Perimeter:**
- **Length:**
- **Width:**
- **Shape:**

D5.2 VHR land cover maps

**EDGE ATTRIBUTES** (if any):

**Additional info:** None (or not relevant)

**Conservation Status:** None (or not relevant)

-----  
**NODE:**A12/A1.A4.D1.E1+O3.M213.N12-LP+Myrto\_Pistacietum

Natural and semi-natural terrestrial vegetation/Woody.Shrubs.Broad-leaved.Evergreen

**+Environmental Attribute:**

- **WATER QUALITY:** none
- **CLIMATE:** Subtropics-Winter Rainfall (**O3**)
- **LITHOLOGY:** Unconsolid-clastic sedimentary rock-sand(**M213**)
- **SOIL SURFACE ASPECT:** none
- **SOIL SUBSURFACE ASPECT:** Leptosols (**N12-LP**)

**+Technical Attribute:** Myrto-Pistacietum

This class corresponds to the habitat: 5330

**Short habitat description:**

Terrestrial natural areas – woody vegetation characterized by broad-leaved evergreen medium-high sclerophyllous shrubs - height 0,8-2 m.

High density (high cover)

Presence of sand or outcropping calcareous rocks as background.

Adjacent to habitat 2110 or 2250 towards the sea. On the other side, adjacent to habitat 1410, or F5.514, or to G3.F1 or to D5.1.

Distributed next to the coastline, in a band (parallel to the coastline) of variable width, from a few to several hundred meters, based on the geomorphology of the coastal belt.

- **Position:**
- **Centroid:**
- **Angle:**
- **Compactness:**
- **Rectangularity:**
- **Elongation:**
- **Straightness of boundaries:**
- **List of skeleton endpoints with attributes: position, angle, inter-endpoint distance**

**Morphological attributes:**

**Textural attributes:**

- **With Structure**
- **With no Structure**

5(5.1)

***EDGES:***

***Non - spatial relationships:***

Class (***IS A***) Natural and semi-natural terrestrial vegetation (***A12***)

Class **Foreground:**

- **T1 January-December:** Woody Shrubs Broad-leaved (**PART-OF**) (height in [0.8–2] m)

Class **Background:**

- **T1 January-December:** calcareous rock (**PART-OF**) or sand (**PART-OF**)

***Spatial-non topological relations:***

- Woody Shrubs growing in proximity (about 10-100 m) of the coastline\_

***Spatial topological relations:***

- **Adjacent to:**
  - **Towards the sea:** A12/A2.A6.E6 (habitat 2110) or A12/A1.A4.D2.E1 (habitat 2250);
  - **On the other side:** A24/A2.A6.E6 (habitat 1410) or A12/A1.A4.D1.E1 (habitat F5.514) or A11/A1.A8.A9.W7 (habitat G3.F1) or A24/A2.A6.E6 (habitat D5.1) or A12/A2.A5.E7 (habitat 6220)

***Temporal relations:***

- **Class phenology:** Evergreen

***CLASS ATTRIBUTES:***

**Cover:** closed (> 65%) (high density)

Class **Photometric/Phenological attributes:**

- **T1 January-December:** green

**Geometric attributes:** None (or not relevant)

**Morphological attributes:** None (or not relevant)

**Textural attributes:** None (or not relevant)

***EDGE ATTRIBUTES*** (if any):

**Additional info:** None (or not relevant)

**Conservation Status:** None (or not relevant)

-----  
**NODE:A12/A1.A4.D1.E1+O3.M233.N12-LP+Pistacia\_lentiscus**

Natural and semi-natural terrestrial vegetation/Woody.Shrubs.Broad-leaved.Evergreen

**+Environmental Attribute:**

- **WATER QUALITY:** none
- **CLIMATE:** Subtropics-Winter Rainfall (**O3**)
- **LITHOLOGY:** Calcareous rock-calcarenite(**M233**)
- **SOIL SURFACE ASPECT:** none
- **SOIL SUBSURFACE ASPECT:** Leptosols (**N12-LP**)

**+Technical Attribute:** Pistacia lentiscus

This class corresponds to the habitat: Eunis F5.514

**Short habitat description:**

Terrestrial natural areas – woody vegetation characterized by broad-leaved evergreen



## D5.2 VHR land cover maps

medium-high sclerophyllous shrubs - height 0,8-2 m.

High density (high cover)

**5(5.2)** Presence of outcropping calcareous rocks as background.

Adjacent to habitat G3.F1 or to F6.2C or to D5.1.

Distributed in inland areas, not next to the coastline, in correspondence of calcareous geological substrata.

### ***EDGES:***

#### **Non - spatial relationships:**

Class (**IS A**) Natural and semi-natural terrestrial vegetation (**A12**)

#### Class **Foreground:**

- **T1 January-December:** Woody Shrubs Broad-leaved (**PART-OF**) (height in [0.8–2] m)

#### Class **Background:**

- **T1 January-December:** calcareous rock (**PART-OF**)

#### **Spatial-non topological relations:**

- Woody Shrubs growing far from (about > 100 m) the coastline\_

#### **Spatial topological relations:**

- **Adjacent to:** A11/A1.A8.A9.W7 (habitat G3.F1) or A12/A1.A4.D1.E1 (habitat F6.2C) or A24/A2.A6.E6 (habitat D5.1) or A12/A1.A4.D1.E1 (habitat 5330) or A24/A2.A6.E6 (habitat 1410)

#### **Temporal relations:**

- **Class phenology:** Evergreen

**CLASS ATTRIBUTES:**

**Cover:** closed (> 65%) (high density)

Class **Photometric/Phenological attributes:**

- **T1 January-December:** green

**Geometric attributes:** None (or not relevant)

**Morphological attributes:** None (or not relevant)

**Textural attributes:** None (or not relevant)

**EDGE ATTRIBUTES** (if any):

**Additional info:** None (or not relevant)

**Conservation Status:** None (or not relevant)

**Class: A12/A2.A6.E6**

<p>7</p>	<p><b>NODE:A12/A1.A4.D1.E1+O3.M233.N12-LP+Agropyron_junceum</b></p> <p>Natural and semi-natural terrestrial vegetation/Herbaceous.Graminoid.Perennial</p> <p><b>+Environmental Attribute:</b></p> <ul style="list-style-type: none"> <li>• <b>WATER QUALITY:</b> none</li> <li>• <b>CLIMATE:</b> Subtropics-Winter Rainfall (O3)</li> <li>• <b>LITHOLOGY:</b> Unconsolidated-clastic sedimentary rock-sand(M213)</li> <li>• <b>SOIL SURFACE ASPECT:</b> Loose and shifting sands, with dunes (N7)</li> <li>• <b>SOIL SUBSURFACE ASPECT:</b> Arenosols (N12-AR)</li> </ul> <p><b>+Technical Attribute:</b> Agropyron junceum</p> <p>This class corresponds to the habitat: 2110</p>  <p style="text-align: center;"><b>Picture taken on September 2007</b></p>	<p><b>Photometric:</b></p> <p><b>Summer(July-2005):QUICKBIRD (spatial resolution=2.4 m)</b></p> <ul style="list-style-type: none"> <li>○ <u>Foreground SIAM spectral categories.</u> Not significant.</li> <li>○ <u>Background SIAM spectral categories.</u> Soil: 32 BBB_TNCL, 33 SBBVF_LSC, 34 SBBF, 35 SBBNF_LSC, 36 ABBVF, 38 ABBNF_LSC, 62 SN_CL_BBB_LSC</li> </ul> <p><b>Summer(June-2009):QUICKBIRD (spatial resolution=2.4 m)</b></p> <ul style="list-style-type: none"> <li>○ <u>Foreground SIAM spectral categories.</u> <u>Vegetation</u> : 22 ASHRBR MNIR, 23 ASHRBR LNIR</li> <li>○ <u>Background SIAM spectral categories.</u> <ul style="list-style-type: none"> <li>○ <u>Soil:</u> 32 BBB_TNCL, 33 SBBVF_LSC, 34 SBBF, 35 SBBNF_LSC, 36 ABBVF, 38 ABBNF_LSC, 62 SN_CL_BBB_LSC</li> <li>○ <u>Water:</u> 50 DPWASH_LSC</li> </ul> </li> </ul> <p><b>Fall(October-2009):WORLDVIEW-2 (spatial resolution=2 m)</b></p> <ul style="list-style-type: none"> <li>○ <u>Foreground SIAM spectral categories.</u> <u>Vegetation:</u> 22 ASHRBR MNIR</li> <li>○ <u>Background SIAM spectral categories:</u> <ul style="list-style-type: none"> <li>○ <u>Soil:</u> 33 SBBVF_LSC, 36 ABBVF, 38 ABBNF_LSC, 39 DBBVF, 62 SN_CL_BBB_LSC</li> <li>○ <u>Water:</u> 52 TWASH_LSC</li> </ul> </li> </ul>
----------	--	---

## D5.2 VHR land cover maps

### Short habitat description:

Terrestrial natural areas – herbaceous perennial vegetation of graminoid plants (cespitous hemicriptophytes), with a peak of biomass (greyish-green) from May to August and minor biomass with withered/dry plants (most of the aerial part) in the rest of the year.

Distributed along the sandy shores, usually arranged in an elongated shape, forming a more or less continuous strip (width > 1,5 m) parallel to the coastline.

Low density (low-medium cover)

Adjacent to habitat 1210 (A12/A2.A5.E7) towards the sea, and adjacent to 2250 (A12/A1.A4.D2.E1) and/or to 5330 (A12/A1.A4.D1.E1) towards the inland.

Sandy shores – embryo dunes - sand (background).

### EDGES:

#### Non - spatial relationships:

Class (IS A) Natural and semi-natural terrestrial vegetation (A12)

#### Class **Foreground:**

- **T1 January-December:** Herbaceous Graminoid Perennial (**PART-OF**) (height in [0.6 – 0.7] m)

#### Class **Background:**

- **T1 January-December:** sand (**PART-OF**)

### Spatial-non topological relations:

- Herbaceous Graminoid growing close to (3-5 to 10-15, depending on the degree of coastal erosion) coastline\_

### Spatial topological relations:

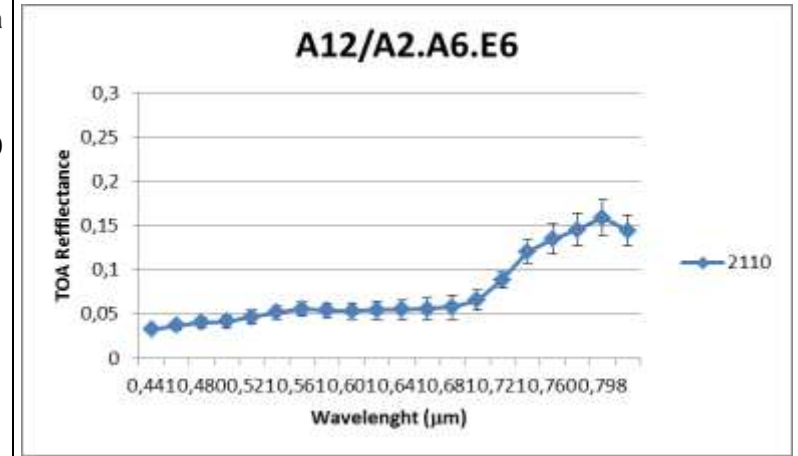

MIVIS VNIR Spectrum acquired on 24<sup>th</sup> May 2009  
(spatial resolution =3m)

### Geometric attributes:

- **Area:**
- **Perimeter:**
- **Length:**
- **Width:**
- **Shape:**
- **Position:**
- **Centroid:**
- **Angle:**
- **Compactness:**

## D5.2 VHR land cover maps

- **Adjacent to:**
  - **Towards the sea:** A12/A2.A5.E7 (habitat 1210);
  - **On the other side:** A12/A1.A4.D2.E1 (habitat 2250) or A12/A1.A4.D1.E1 (habitat 5330) or A24/A2.A6.E6 (habitat 1410)

### Temporal relations:

- **Class phenology:** Perennial

### **CLASS ATTRIBUTES:**

**Cover:** open (65-40%) to closed (80%)

### Class **Photometric/Phenological attributes:**

- **T1\_1 May-August:** pale green
- **T1\_2 September-April:** grey-yellow

### Geometric attributes:

- **Width:** > 2m
- **Shape:** linear
- **Position:** parallel to the coastline

**Morphological attributes:** None (or not relevant)

**Textural attributes:** None (or not relevant)

**EDGE ATTRIBUTES** (if any):

**Additional info:** None (or not relevant)

**Conservation Status:** None (or not relevant)

- **Rectangularity:**
- **Elongation:**
- **Straightness of boundaries:**
- **List of skeleton endpoints with attributes:** position, angle, inter-endpoint distance

### Morphological attributes:

### Textural attributes:

- **With Structure**
- **With no Structure**

## D5.2 VHR land cover maps

**Class: A24/A2.A5.E7**

<p>9(9.1)</p>	<p><b>NODE:A24/A2.A5.E7+R1.O3.M233+Annuals_of_Isoeto-Nanojuncetea</b></p> <p>Natural and semi-natural aquatic or regularly flooded vegetation/Herbaceous.Forbs.Annual</p> <p><b>+Environmental Attribute:</b></p> <ul style="list-style-type: none"> <li>• <b>WATER QUALITY:</b> Fresh water (R1)</li> <li>• <b>CLIMATE:</b> Subtropics-Winter Rainfall (O3)</li> <li>• <b>LITHOLOGY:</b> Calcareous rock-calcarenite (M233)</li> <li>• <b>SOIL SURFACE ASPECT:</b> Soil Surface (N2)</li> <li>• <b>SOIL SUBSURFACE ASPECT:</b> no data</li> </ul> <p><b>+Technical Attribute:</b> Annuals of Isoeto-Nanojuncetea</p> <p>This class corresponds to the habitat: 3170</p> <p><b><u>Short habitat description:</u></b></p> <p>Aquatic natural areas – herbaceous annual vegetation of non graminoid short (0.1-0.4 m) plants, characterized by a short life cycle (green) from March to May.</p> <p>Amphibious vegetation of temporary ponds – very shallow ponds occurring in substrate depressions, with a periodic cycle of flooding (in winter) and drought in spring.</p> <p>Adjacent to habitat G2.91 or I1.3</p> <p>Medium-low density</p> <p>Wet soil as background</p> <p>Small patches</p> <p><b>EDGES:</b></p> <p><b><u>Non - spatial relationships:</u></b></p> <p>Class (IS A) Natural and semi-natural aquatic or regularly flooded vegetation (A24)</p> <p>Class <b>Foreground:</b></p>	<p><b>Photometric:</b></p> <p><b>Summer(July-2005):QUICKBIRD(spatial resolution=2.4 m)</b></p> <ul style="list-style-type: none"> <li>○ <u>Foreground SIAM spectral categories. Vegetation :</u> 21 ASHRBR HNIR, 22 ASHRBR MNIR, 23 ASHRBR LNIR,</li> <li>○ <u>Background SIAM spectral categories.</u> <ul style="list-style-type: none"> <li>○ <u>Soil:</u> 35 SBBNF_LSC, 36 ABBVF, 38 ABBNF_LSC,39 DBBVF.</li> <li>○ <u>Water:</u> 50 DPWASH_LSC, 52 TWASH_LSC</li> </ul> </li> </ul> <p><b>Summer(June-2009):QUICKBIRD(spatial resolution=2.4m)</b></p> <ul style="list-style-type: none"> <li>○ <u>Foreground SIAM spectral categories. Vegetation :</u> 21 ASHRBR HNIR, 22 ASHRBR MNIR, 23 ASHRBR LNIR</li> <li>○ <u>Background SIAM spectral categories.</u> <ul style="list-style-type: none"> <li>○ <u>Soil:</u> 36 ABBVF, 38 ABBNF_LSC,39 DBBVF, 41 DBBNF_LSC, 62 SN_CL_BBB_LSC</li> <li>○ <u>Water:</u> 52 TWASH_LSC</li> </ul> </li> </ul> <p><b>Fall(October-2009):WORLDVIEW-2(spatial resolution=2m)</b></p> <ul style="list-style-type: none"> <li>○ <u>Foreground SIAM spectral categories. Vegetation :</u> 21 ASHRBR HNIR, 22 ASHRBR MNIR, 23 ASHRBR LNIR</li> <li>○ <u>Background SIAM spectral categories:</u> <ul style="list-style-type: none"> <li>○ <u>Soil:</u> 35 SBBNF_LSC, 36 ABBVF, 38 ABBNF_LSC,39 DBBVF, 40 DBBF, 62 SN_CL_BBB_LSC</li> <li>○ <u>Water:</u> 50 DPWASH_LSC, 52 TWASH_LSC.</li> </ul> </li> </ul>
---------------	--	--

## D5.2 VHR land cover maps

- **T1 March-May:** herbaceous short forbs Annual (**PART-OF**) (height in [0.2 – 0.4] m; small patch)
- **T2 June-October:** soil (**PART OF**)
- **T3 November-February:** water (**PART OF**)

### Class Background:

- **T1 March-May:** wet soil (**PART-OF**)
- **T2 June-October:** Background coincides with Foreground
- **T3 November-February:** Background coincides with Foreground

**Spatial-non topological relations:** None (or not relevant)

### Spatial topological relations:

- **Adjacent to:**
  - **T1 March-May:** A11/A1.A7.A9.W8 (habitat G2.91) or A11/A3.A5 (habitat I1.3). See Figure 1

### Temporal relations:

- **Class phenology:** Annual

### **CLASS ATTRIBUTES:**

**Cover:** from open (40-(20-10) %) to open (40-(60-70)%)

### Class Photometric/Phenological attributes:

- **T1 March-May:** green
- **T2 June-October:** no visible plants
- **T3 November-February:** no visible plants

**Geometric attributes:** None (or not relevant)

**Morphological attributes:** None (or not relevant)

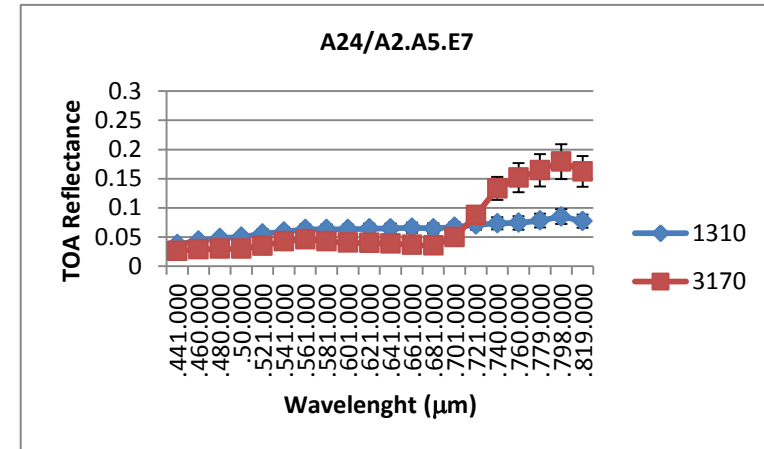

MIVIS VNIR Spectrum acquired on 24<sup>th</sup> May 2009  
(spatial resolution =3m)

### Geometric attributes:

- **Area:**
- **Perimeter:**
- **Length:**
- **Width:**
- **Shape:**



D5.2 VHR land cover maps

**Textural attributes:** None (or not relevant)

***EDGE ATTRIBUTES*** (if any):

**Additional info:** None (or not relevant)

**Conservation Status:** None (or not relevant)

-----  
**NODE:**A24/A2.A5.E7+R3/R2.O3.M213+N2+N12-  
**SC+salicornia\_spp\_Suaeda\_spp\_Parapholis\_spp\_or\_annuals\_of\_Thero-Salicornietea\_and/or\_Saginetea\_maritimae**

Natural and semi-natural aquatic or regularly flooded vegetation/Herbaceous.Forbs.Annual

**+Environmental Attribute:**

- **WATER QUALITY:** Saline/brackish water (**R3/R2**)
- **CLIMATE:** Subtropics-Winter Rainfall (**O3**)
- **LITHOLOGY:** Unconsolid-clastic sedimentary rock-sand (**M213**)
- **SOIL SURFACE ASPECT:** Soil Surface (**N2**)
- **SOIL SUBSURFACE ASPECT:** Solonchak (**N12-SC**)

**+Technical Attribute:** Salicornia spp.; Suaeda spp.; Parapholis spp. or annuals of Thero-Salicornietea and/or Saginetea maritimae

It corresponds to **Habitat:** 1310 (Eunis: A2.51 or A2.55 (see D5.1))

- **Position:**
- **Centroid:**
- **Angle:**
- **Compactness:**
- **Rectangularity:**
- **Elongation:**
- **Straightness of boundaries:**
- **List of skeleton endpoints with attributes: position, angle, inter-endpoint distance**

**Morphological attributes:**

**Textural attributes:**

- **With Structure**
- With no Structure**

- **Perimeter:**
- **Length:**
- **Width:**
- **Shape:**
- **Position:**
- **Centroid:**
- **Angle:**
- **Compactness:**
- **Rectangularity:**
- **Elongation:**
- **Straightness of boundaries:**
- **List of skeleton endpoints with attributes: position, angle, inter-endpoint distance**

**Morphological attributes:**

**Textural attributes:**

- **With Structure**
- With no Structure**

9(9.2 or 9.3)

D5.2 VHR land cover maps



**Picture taken on October 2007**

D5.2 VHR land cover maps



**Picture taken on June 2007**



**Picture taken on June 2007**

## D5.2 VHR land cover maps

### **Short habitat description:**

Aquatic natural areas – herbaceous annual vegetation of non graminoid plants, composed mostly of annual glassworts (height 0,2-0,4 m) colonising periodically inundated muds of coastal saltmarshes - vegetative cycle from June to October (greyish green to reddish green) with maximum biomass in August-September.

This vegetation, during its vegetative cycle, usually forms a belt (width > 1 to 10 m) around the coastal lagoons. In this case, it does not come to form a belt, but strips (elongated patches) along the edge of the lagoon (on the sea side).

In winter (from November to March) the area is flooded by the salt or brackish waters of the lagoon. In spring (April-May), water tends to dry up and recede, leaving out the substrate (mud or sands) of the edges of the lagoon. In summer (starting from May-June) the young plants emerge in this area, initially in an sparse coverage and then thickening in July-October.

Adjacent to habitat 1150 (A24/A2.A5.E6) towards the lagoon and adjacent to habitat to 1410 (A24/A2.A6.E6) towards the other side.

Density: from low (May-June) to medium-high (September) according to the month of observation.

Mud or sand as background.

### ***EDGES:***

### **Non - spatial relationships:**

Class (**IS A**) Natural and semi-natural aquatic or regularly flooded vegetation (**A24**)

### Class **Foreground:**

- **T1 June-October:** herbaceous short forbs (**PART-OF**) (height in [0.2 – 0.4] m)
- **T2 November-March:** water lagoon (**PART OF**)
- **T3 April-May:** wet sand (**PART OF**)

### Class **Background:**

- **T1 June–October:** sand (**PART-OF**)
- **T2 November-March:** Background coincides with Foreground
- **T3 April- May:** Background coincides with Foreground

### **Spatial-non topological relations:**

## D5.2 VHR land cover maps

- Herbaceous short forbs growing in proximity (a few decimeters to 8-10 m, in this specific site) of coastal lagoons

### **Spatial topological relations:**

- **Adjacent to:**
  - **T1 June–October:**
    - **To the lagoon:** A24/A2.A5.E6 (habitat 1150);
    - **On the other side:** more frequently to class A24/A2.A6.E6 (habitat 1410) and less frequently A24/A1.A4.D3 (habitat 1420).

### **Temporal relations:**

- **Class phenology:** annual

### **CLASS ATTRIBUTES:**

**Cover:** from open (40-(20-10)%) to open (40-(60-70)%)

### Class **Photometric/Phenological attributes:**

- **T1 May–October:** green-grey-reddish (peak of biomass in August–September)
- **T2 November–April:** no visible plants
- **T3 April–May:** some plants in a sand background (white)

### **Geometric attributes:**

- **Width:** width >1 m
- **Shape:** linear
- **Position:** along the boundary of the lagoon

**Morphological attributes:** None (or not relevant)

**Textural attributes:** None (or not relevant)

D5.2 VHR land cover maps

***EDGE ATTRIBUTES*** (if any):

**Additional info:** None (or not relevant)

**Conservation Status:** None (or not relevant)

**Class: A24/A1.A4.D3**

<p>10</p>	<p><b>NODE:</b>A24/A1.A4.D3+R2/R3.O3.M213.N12-SC+Sarcocornia_spp_ Suaeda_vera_Arthrocnemum_spp_or_perennial_species_of_Sarcocornie tea</p> <p>Natural and semi-natural aquatic or regularly flooded vegetation/Woody.Shrubs. Aphyllous</p> <p><b>+Environmental Attribute:</b></p> <ul style="list-style-type: none"> <li>• <b>WATER QUALITY:</b> Saline/brackish water (R2/R3)</li> <li>• <b>CLIMATE:</b> Subtropics-Winter Rainfall (O3)</li> <li>• <b>LITHOLOGY:</b> Unconsolidated-clastic sedimentary rock-sand(M213)</li> <li>• <b>SOIL SURFACE ASPECT:</b> no data</li> <li>• <b>SOIL SUBSURFACE ASPECT:</b> Solonchak (N12-SC)</li> </ul> <p><b>+Technical Attribute:</b> Sarcocornia spp.; Suaeda vera; Arthrocnemum spp. or perennial species of Sarcocornietea</p> <p>This class corresponds to the habitat: 1420</p> <p><b><u>Short habitat description:</u></b></p> <p>Aquatic natural areas – woody vegetation of perennial halophytes, mainly succulent chamaephytes and nano-phanerophytes (height 0.5-1 m) colonising saline marine muds (coastal saltmarshes) – this vegetation shows a peak of biomass (greyish green) from June to September.</p> <p>Generally this habitat is located in proximity (around) of coastal lagoons with saline waters.</p> <p>In winter the background is water lagoon (November-March) or waterlogged soil, in spring (April-May) the background is wet soil, in summer (June-October) the background is dried soil on the surface.</p> <p>Towards the lagoons this vegetation is adjacent to water in winter and to habitat 1310 (A24/A2.A5.E7) in summer; on the other side is usually adjacent to 1410 (A24/A2.A6.E6).</p>	<p><b>Photometric:</b></p> <p><b>Summer(July-2005): QUICKBIRD (spatial resolution=2.4 m)</b></p> <ul style="list-style-type: none"> <li>○ <u>Foreground SIAM spectral categories.</u> <u>Tree crown</u> : 21 ASHRBR HNIR, 22 ASHRBR MNIR, 23 ASHRBR LNIR, 29 PB LSC</li> <li>○ <u>Background SIAM spectral categories.</u> <ul style="list-style-type: none"> <li>○ <u>Soil:</u> 35 SBBNF_LSC, 36 ABBVF, 38 ABBNF_LSC,39 DBBVF, 41 DBBNF_LSC</li> <li>○ <u>Water:</u> 50 DPWASH_LSC, 52 TWASH_LSC</li> </ul> </li> </ul> <p><b>Summer(June- 2009):QUICKBIRD (spatial resolution=2.4 m)</b></p> <ul style="list-style-type: none"> <li>○ <u>Foreground SIAM spectral categories.</u> <u>Tree crown</u> : 22 ASHRBR MNIR, 23 ASHRBR LNIR, 24 ASHRBR VLNIR</li> <li>○ <u>Background SIAM spectral categories.</u> <ul style="list-style-type: none"> <li>○ <u>Soil:</u> 35 SBBNF_LSC, 36 ABBVF, 37 ABBF, 38 ABBNF_LSC, 39 DBBVF</li> <li>○ <u>Water:</u> 52 TWASH_LSC</li> </ul> </li> </ul> <p><b>Fall(October-2009):WORLDVIEW-2 (spatial resolution=2 m)</b></p> <ul style="list-style-type: none"> <li>○ <u>Foreground SIAM spectral categories.</u> <u>Tree crown</u> : 17 SHV_WEDR, 21 ASHRBR HNIR, 22 ASHRBR MNIR, 23 ASHRBR LNIR</li> <li>○ <u>Background SIAM spectral categories:</u> <ul style="list-style-type: none"> <li>○ <u>Soil:</u> 35 SBBNF_LSC, 36 ABBVF, 38 ABBNF_LSC</li> <li>○ <u>Water:</u> 52 TWASH_LSC</li> </ul> </li> </ul> <p>The patches are too small to obtain a representative MIVIS VNIR spectrum.</p> <p><b><u>Geometric attributes:</u></b></p>
-----------	---	---

## D5.2 VHR land cover maps

Low to medium-high density

The presence of this habitat indicates salt water (salinization). In the case of IT4 its presence is indicative of increased salinity of waters.

Elements for the state assessment:

Breaking down of the sand bank;  
slope and width of the sand bank;  
distance from the coastline

### **EDGES:**

#### **Non - spatial relationships:**

Class (*IS A*) Natural and semi-natural aquatic or regularly flooded vegetation (**A24**)

#### Class **Foreground:**

- **T1 January-December:** Aphyllous high dwarf (height < 0.5 m) or medium-high (height < 0.8 m) shrubs (**PART-OF**)

#### Class **Background:**

- **T1\_2 November-March:** brackish/salt water of coastal lagoon (**PART-OF**) or water logged soil (**PART-OF**)
- **T1\_3 April-June:** wet soil (**PART-OF**)
- **T1\_4 July–October:** dry (at the surface) soil-sand (**PART-OF**)

**Spatial-non topological relations:** None (or not relevant)

#### **Spatial topological relations:**

- **Adjacent:**
  - **T1\_2 November-March:**
    - **Towards the lagoon:** water of coastal lagoon;
    - **On the other side:** A24/A2.A6.E6 (habitat 1410)
  - **T1\_3 April-June:**
    - **Towards the lagoon:** water logged soil;

- **Area:**
- **Perimeter:**
- **Length:**
- **Width:**
- **Shape:**
- **Position:**
- **Centroid:**
- **Angle:**
- **Compactness:**
- **Rectangularity:**
- **Elongation:**
- **Straightness of boundaries:**
- **List of skeleton endpoints with attributes: position, angle, inter-endpoint distance**

#### **Morphological attributes:**

#### **Textural attributes:**

- **With Structure**
- **With no Structure**
- **With no Structure**



## D5.2 VHR land cover maps

- **On the other side:** A24/A2.A6.E6 (habitat 1410)
- **T1\_4 July–October:**
  - **Towards the lagoon:** A24/A2.A5.E7 (habitat 1310);
  - **On the other side:** A24/A2.A6.E6 (habitat 1410)

### **Temporal relations:**

- **Class phenology:** see Figure 1

### **CLASS ATTRIBUTES:**

**Cover:** open (70-60)-40% to closed 70-100%

### Class **Photometric/Phenological attributes:**

- **T2+T3 November-June:** grey to greyishgreen
- **T4 July-October:** greyish green

**Geometric attributes:** None (or not relevant)

**Morphological attributes:** None (or not relevant)

**Textural attributes:** None (or not relevant)

**EDGE ATTRIBUTES** (if any):

**Additional info:** None (or not relevant)

**Conservation Status:** salinization process of water lagoons in progress

- Break-down of the sand-bank;
- Erosion of the sand-bank;
- Reduced distance from the coastline

D5.2 VHR land cover maps

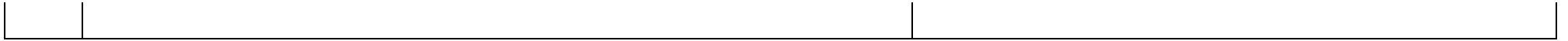

**Class: A24/A2.A6.E6**

<p>11(11.1)</p>	<p><b>NODE:</b>A24/A2.A6.E6+R2/R3.O3.M213.N12-SC+Juncus_spp_Carex_spp_Plantago_crassifolia_or_perennial_species_of_Juncetea_maritime</p> <p>Natural and semi-natural aquatic or regularly flooded vegetation/Herbaceous.Graminoid.Perennial</p> <p><b>+Environmental Attribute:</b></p> <ul style="list-style-type: none"> <li>• <b>WATER QUALITY:</b> Saline/brackish water (R2/R3)</li> <li>• <b>CLIMATE:</b> Subtropics-Winter Rainfall (O3)</li> <li>• <b>LITHOLOGY:</b> Unconsolid-clastic sedimentary rock-sand(M213)</li> <li>• <b>SOIL SURFACE ASPECT:</b> no data</li> <li>• <b>SOIL SUBSURFACE ASPECT:</b> Solonchak (N12-SC)</li> </ul> <p><b>+Technical Attribute:</b> Juncus spp.; Carex spp.; Plantago crassifolia; or perennial species of Juncetea maritimi</p> <p>This class corresponds to the habitat: 1410</p>  <p style="text-align: center;"><b>Picture taken on September 2007</b></p>	<p><b>Photometric:</b></p> <p><b>Summer(July-2005): QUICKBIRD (spatial resolution=2.4 m)</b></p> <ul style="list-style-type: none"> <li>○ <u>Foreground SIAM spectral categories.</u> <u>Vegetation:</u> 21 ASHRBR HNIR, 22 ASHRBR MNIR, 23 ASHRBR LNIR, 29 PB LSC</li> <li>○ <u>Background SIAM spectral categories.</u> <u>Soil:</u> 32 BBB_TNCL, 35 SBBNF_LSC</li> </ul> <p><b>Summer(June- 2009):QUICKBIRD (spatial resolution=2.4 m)</b></p> <ul style="list-style-type: none"> <li>○ <u>Foreground SIAM spectral categories.</u> <u>Vegetation :</u> 3 SVVHNIR, 4 SVHNIR, 21 ASHRBR HNIR, 22 ASHRBR MNIR, 23 ASHRBR LNIR, 24 ASHRBR VLNIR</li> <li>○ <u>Background SIAM spectral categories.</u> <ul style="list-style-type: none"> <li>○ <u>Soil:</u> 41 DBBNF_LSC</li> <li>○ <u>Water:</u> 50 DPWASH_LSC</li> </ul> </li> </ul> <p><b>Fall(October-2009):WORLDVIEW-2 (spatial resolution=2 m)</b></p> <ul style="list-style-type: none"> <li>○ <u>Foreground SIAM spectral categories:</u> <u>Vegetation:</u> 17 SHV_WEDR, 21 ASHRBR HNIR, 22 ASHRBR MNIR, 23 ASHRBR LNIR, 24 ASHRBR VLNIR</li> <li>○ <u>Background SIAM spectral categories:</u> <u>Soil:</u> 38 ABBNF_LSC, 41 DBBNF_LSC</li> </ul> <p><b><u>Geometric attributes:</u></b></p> <ul style="list-style-type: none"> <li>• <b>Area:</b></li> <li>• <b>Perimeter:</b></li> <li>• <b>Length:</b></li> <li>• <b>Width:</b></li> <li>• <b>Shape:</b></li> <li>• <b>Position:</b></li> </ul>
-----------------	--	---



Picture taken on September 2007

**Short habitat description:**

Aquatic natural areas – herbaceous perennial vegetation of graminoid plants, composed mostly of sedges, rushes and reeds (height 0,8-2 m) colonising periodically inundated muds of coastal saltmarshes – This vegetation has a maximum of biomass (greyish-brownish green ) in June-September and minor biomass with dry plants (most of the aerial part) in the rest of the year.

Generally this habitat is located in proximity (around) of water bodies, coastal lagoons with salt or brackish waters.

The background is water or waterlogged soil in winter (November-March), moist soil in spring, sand or mud in summer.

This vegetation is adjacent, towards the lagoon: in winter to habitat 1150 and, in summer to habitat 1310 (A24/A2.A5.E7). On the other side, it is adjacent to: habitat 2110 or 2250 (next the sand bank) and/or to habitat D5.1 (A24/A2.A6.E6).

High density.

**EDGES:**

**Non - spatial relationships:**

Class (**IS A**) Natural and semi-natural aquatic or regularly flooded vegetation (**A24**)

- **Centroid:**
- **Angle:**
- **Compactness:**
- **Rectangularity:**
- **Elongation:**
- **Straightness of boundaries:**
- **List of skeleton endpoints with attributes: position, angle, inter-endpoint distance**

**Morphological attributes:**

**Textural attributes:**

- **With Structure**
- **With no Structure**

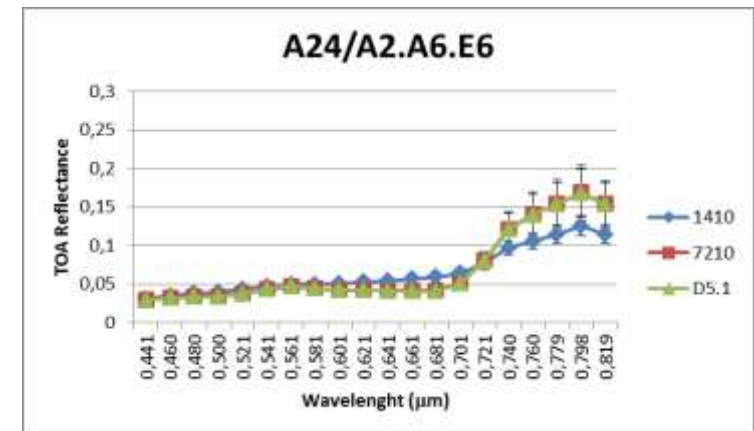

MIVIS VNIR Spectrum acquired on 24<sup>th</sup> May 2009  
(spatial resolution =3m)

## D5.2 VHR land cover maps

### Class **Foreground:**

- **T1 January-December:** Herbaceous graminoid (height in [0.8-2] m ) (**PART-OF**)

### Class **Background:**

- **T1\_2 November-March:** brackish/salt water of coastal lagoon (**PART-OF**) or water logged soil (**PART-OF**)
- **T1\_3 April-June:** wet soil (**PART-OF**)
- **T1\_4 July–October:** mud or sand (**PART-OF**)

**Spatial-non topological relations:** None (or not relevant)

### **Spatial topological relations:**

- **Adjacent:**
  - **T1\_2 November-March:** water of coastal lagoon;
  - **T1\_3+T1\_4 April-October:**
    - **Towards the lagoon:** A24/A2.A5.E7 (habitat 1310) or A24/A2.A5.E6 (habitat 1150) or water of coastal lagoon
    - **On the other side:**
      - **If close to coastline:** A12/A2.A6.E6 (habitat 2110) or A24/A1.A4.D3 (habitat 1420) , or A12/A1.A4.D2.E1 (habitat 2250)
      - **If towards the inland part:** A24/A2.A6.E6 (habitat D5.1) or A12/A1.A4.D1.E1 (habitat F5.514) or A12/A1.A4.D1.E1 (habitat 5330) or A24/A2.A6.E6 (habitat 7210) or A24/A2.A6.E6 (habitat D5.2)

### **Temporal relations:**

- **Class phenology:** Perennial

### **CLASS ATTRIBUTES:**

**Cover:** closed 90-100%

### Class **Photometric/Phenological attributes:**

D5.2 VHR land cover maps

- **T3+T4 April-October:** greyish-green (peak of biomass in June-September)
- **T2 November-March:** grey to greyish green-yellow

**Geometric attributes:**

- **Shape:** linear
- **Position:** parallel to the coastline or along the boundary of the lagoon

**Morphological attributes:** None (or not relevant)

**Textural attributes:** None (or not relevant)

***EDGE ATTRIBUTES*** (if any):

**Additional info:** None (or not relevant)

**Conservation Status:** None (or not relevant)

-----

**NODE:A24/A2.A6.E6+R1.O3.M233.N12-HS+Cladium\_mariscus**

11(11.2) Natural and semi-natural aquatic or regularly flooded vegetation/  
Herbaceous.Graminoid.Perennial

**+Environmental Attribute:**

- **WATER QUALITY:** Fresh water (R1)
- **CLIMATE:** Subtropics-Winter Rainfall (O3)
- **LITHOLOGY:** Calcareous rock-calcarenite (M233)
- **SOIL SURFACE ASPECT:** no data
- **SOIL SUBSURFACE ASPECT:** Histosols (N12-HS)

**+Technical Attribute:** Cladium mariscus

D5.2 VHR land cover maps

This class corresponds to the habitat: 7210



Picture taken on July 2007



**Picture taken on May 2007**



**Picture taken on October 2007**

**Short habitat description:**

Aquatic natural areas – herbaceous perennial vegetation of graminoid plants, composed mostly of fen sedges (height 1-2 m), colonising periodically inundated coastal areas and wet meadows with flooded or waterlogged soil for most of the year– This vegetation has a maximum of biomass (greyish-brownish green ) in June-September and less biomass with dry plants (most of the aerial part) in the rest of the year.

The background is water or waterlogged soil in winter (November-March), moist soil or waterlogged soil in spring, (moist) sand or mud in summer.

This vegetation is adjacent with habitat 1410 (A24/A2.A6.E6) or habitat D5.1 (A24/A2.A6.E6).

High density.

***EDGES:***

**Non - spatial relationships:**



## D5.2 VHR land cover maps

Class (**IS A**) Natural and semi-natural aquatic or regularly flooded vegetation (**A24**)

Class **Foreground**:

- **T1 January-December**: Herbaceous graminoid (height in [1-2] m ) (**PART-OF**)

Class **Background**:

- **T1\_2 November-March**: fresh water of coastal lagoon (**PART-OF**) or water logged soil (**PART-OF**)
- **T1\_3 April-June**: wet soil (**PART-OF**)
- **T1\_4 July-October**: mud or sand (**PART-OF**)

**Spatial-non topological relations**: None (or not relevant)

**Spatial topological relations**:

- **Adjacent**:
  - **If not close to (more than 50-100 m) coastline**: A24/A2.A6.E6 (habitat D5.1)
  - **If close to (about 10 to 50 m) coastline**:
    - **Towards the sandbank**: A24/A2.A6.E6 (habitat 1410)
    - **On the other side**: A24/A2.A6.E6 (habitat D5.1)

**Temporal relations**:

- **Class phenology**: Perennial

**CLASS ATTRIBUTES**:

**Cover**: closed 90-100%

Class **Photometric/Phenological attributes**:

- **T1\_5 October-May**: grey to greyishgreen
- **T1\_6 June-September**: greyish green

**Geometric attributes:**

- **Shape:** linear
- **Position:** parallel to the coastline or along the boundary of the lagoon in correspondence of resurgence of fresh water, and with elevation less than A24/A2.A6.E6 (habitat D5.1)

**Morphological attributes:** None (or not relevant)

**Textural attributes:** None (or not relevant)

***EDGE ATTRIBUTES*** (if any):

**Additional info:** None (or not relevant)

**Conservation Status:** None (or not relevant)

-----  
**NODE:**A24/A2.A6.E6+R2/R3.O3.M233.N12-HS+Phragmites\_australis

Natural and semi-natural aquatic or regularly flooded vegetation/  
Herbaceous.Graminoid.Perennial

11(11.3)

**+Environmental Attribute:**

- **WATER QUALITY:** Saline/brackish water (R2/R3)
- **CLIMATE:** Subtropics-Winter Rainfall (O3)
- **LITHOLOGY:** Calcareous rock-calcarenite (M233)
- **SOIL SURFACE ASPECT:** no data
- **SOIL SUBSURFACE ASPECT:** Histosols (N12-HS)

**+Technical Attribute:** Phragmites australis

This class corresponds to the habitat: Eunis D5.1

## D5.2 VHR land cover maps

### **Short habitat description:**

Aquatic natural areas – herbaceous perennial vegetation of graminoid plants, composed mostly of reeds (height 1,5-3 m) growing on waterlogged soils or also as emergent and fringing vegetation beside water bodies – This vegetation has a maximum of biomass (greyish-brownish green ) in June-September and minor biomass with dry plants (most of the aerial part) in the rest of the year.

Generally the background is water or waterlogged soil in winter (November-March), moist soil in spring, sand or mud in summer.

This vegetation is adjacent, towards the coastal lagoon, with habitat 1410 (A24/A2.A6.E6), 7210 (A24/A2.A6.E6) or 1150. On the other side, it is adjacent to several types of herbaceous and woody, natural and managed vegetation

High density.

### ***EDGES:***

#### **Non - spatial relationships:**

Class (*IS A*) Natural and semi-natural aquatic or regularly flooded vegetation (**A24**)

#### Class **Foreground:**

- **T1 January-December:** Herbaceous graminoid (height in [1.5-3] m ) (**PART-OF**)

#### Class **Background:**

- **T1\_2 November-March:** brackish/salt water of coastal lagoon (**PART-OF**) or water logged soil (**PART-OF**)
- **T1\_3 April-June:** wet soil (**PART-OF**)
- **T1\_4 July–October:** mud or sand (**PART-OF**)

### **Spatial-non topological relations:**

- Herbaceous graminoid growing in proximity of (from few decimeters to 50 m) coastal lagoons

**Spatial topological relations:**

• **Adjacent:**

- **Towards the lagoon:** A24/A2.A6.E6 (habitat 1410) or A24/A2.A6.E6 (habitat 7210) or A24/A2.A5.E6 (habitat 1150);
- **On the other side:** A12/A1.A4.D1.E1 (habitat F5.514) or A11/A1.A8.A9.W7 (habitat G3.F1) or A11/A1.A7.A9.W8 (habitat G2.91) or A11/A3.A5 (habitat I1.3) or A12/A2.A5.E7 (habitat E1.6) or A12/A1.A4.D1.E1 (habitat 5330) or A24/A2.A6.E6 (habitat D5.2)

**Temporal relations:**

- **Class phenology:** Perennial

**CLASS ATTRIBUTES:**

**Cover:** closed 90-100%

Class **Photometric/Phenological attributes:**

- **T1\_5 May-September:** greyish-green (peak of biomass in June-September)
- **T1\_6 October-April:** grey to greyish green-yellow

**Geometric attributes:**

- **Position:** in a zone which has an elevation more than A24/A2.A6.E6 (habitat 7210) and A24/A2.A6.E6 (habitat 1410)

**Morphological attributes:** None (or not relevant)

**Textural attributes:** None (or not relevant)

**EDGE ATTRIBUTES** (if any):

**Additional info:** None (or not relevant)

**Conservation Status:** None (or not relevant)

-----

**NODE:A24/A2.A6.E6+R2/R3.O3.M233.N12-  
SC+Scirpus\_spp\_Bolboschoenus\_maritimus**

Natural and semi-natural aquatic or regularly flooded vegetation/  
Herbaceous.Graminoid.Perennial

11(11.4)

**+Environmental Attribute:**

- **WATER QUALITY:** Saline/brackish water (R2/R3)
- **CLIMATE:** Subtropics-Winter Rainfall (O3)
- **LITHOLOGY:** Calcareous rock-calcarenite (M233)
- **SOIL SURFACE ASPECT:** no data
- **SOIL SUBSURFACE ASPECT:** Solonchak (N12-SC)

**+Technical Attribute:** Scirpus spp.; Bolboschoenus maritimus

This class corresponds to the habitat: Eunis D5.2

D5.2 VHR land cover maps



**Picture taken on June 2007**



**Picture taken on March 2008**

**Short habitat description:**

Aquatic natural areas – herbaceous perennial vegetation of graminoid plants, composed

## D5.2 VHR land cover maps

mostly of sedges and rushes (height 0,8-2 m) colonising periodically inundated muds of coastal saltmarshes – This vegetation has a maximum of biomass (greyish-brownish green ) in June-September and minor biomass with dry plants (most of the aerial part) in the rest of the year.

Generally this habitat is located in proximity (around) of water bodies, coastal lagoons with salt or brackish waters.

The background is water or waterlogged soil in winter (November-March), moist or waterlogged soil in spring, moist sand or mud in summer.

This habitat is adjacent, towards the coastal lagoon, with habitat 1410 (A24/A2.A6.E6) or 1150. On the other side, it is adjacent to habitat D5.1.

High density.

### ***EDGES:***

#### **Non - spatial relationships:**

Class (*IS A*) Natural and semi-natural aquatic or regularly flooded vegetation (**A24**)

#### Class **Foreground:**

- **T1 January-December:** Herbaceous graminoid (height in [0.8-2] m ) (**PART-OF**)

#### Class **Background:**

- **T1\_2 November-March:** brackish/salt water of coastal lagoon (**PART-OF**)
- **T1\_3 April-May:** wet soil (**PART-OF**)
- **T1\_4 June–October:** mud or sand (**PART-OF**)

#### **Spatial-non topological relations:**

- Herbaceous graminoid growing in proximity (few decimeters to 10-20 m) of coastal lagoons\_

#### **Spatial topological relations:**

## D5.2 VHR land cover maps

- **Adjacent:**
  - **Towards the lagoon:** A24/A2.A6.E6 (habitat 1410) or A24/A2.A5.E6 (habitat 1150);
  - **On the other side:** A24/A2.A6.E6 (habitat D5.1)

### Temporal relations:

- **Class phenology:** Perennial

### **CLASS ATTRIBUTES:**

**Cover:** closed 90-100%

### Class Photometric/Phenological attributes:

- **T1\_5 May-September:** greyish-green (peak of biomass in June-September)
- **T1\_6 October-April:** grey to greyish green-yellow

**Geometric attributes:** None (or not relevant)

**Morphological attributes:** None (or not relevant)

**Textural attributes:** None (or not relevant)

**EDGE ATTRIBUTES** (if any):

**Additional info:** None (or not relevant)

**Conservation Status:** None (or not relevant)

-----  
**NODE:**A24/A2.A6.E6+R1/R2.O3.M233+Sparganium\_erectum



## D5.2 VHR land cover maps

Natural and semi-natural aquatic or regularly flooded vegetation/  
Herbaceous.Graminoid.Perennial

### +Environmental Attribute:

- **WATER QUALITY:** Fresh/brackish water (R1/R2)
- **CLIMATE:** Subtropics-Winter Rainfall (O3)
- **LITHOLOGY:** Calcareous rock-calcarenite (M233)
- **SOIL SURFACE ASPECT:** no data
- **SOIL SUBSURFACE ASPECT:** no data

+Technical Attribute: Sparganium erectum

This class corresponds to the habitat: Eunis C2

### Short habitat description:

Aquatic natural areas – herbaceous perennial vegetation of graminoid plants, composed mostly of sedges and rushes (height 0,5-0,8 m) colonising the edges of ditches or drainage canals with fresh or brackish water – This vegetation has a maximum of biomass (greyish-brownish green ) in June-September and minor biomass with dry plants (most of the aerial part) in the rest of the year.

The background is water in winter (November-March), water or waterlogged soil in spring and in summer.

This vegetation is adjacent, towards the canal with water or wet soil. On the other side, it is adjacent to habitat F5.51 (A12/A1.A4.D1.E2) or I1.3 (A11/A3.A5).

High density.

### **EDGES:**

### Non - spatial relationships:

Class (**IS A**) Natural and semi-natural aquatic or regularly flooded vegetation (**A24**)

Class **Foreground:**

- **T1 January-December:** Herbaceous graminoid (height in [0.5-0.8] m ) (**PART-OF**)

12

Class **Background:**

- **T1\_2 November-March:** brackish water of ditches or drainage canal (**PART-OF**)
- **T1\_3 April- October:** wet soil or brackish water of ditches or drainage canal (**PART-OF**)

**Spatial-non topological relations:** None (or not relevant)

**Spatial topological relations:**

- **Adjacent:**
  - **Towards the ditches:** water;
  - **On the other side:** A12/A1.A4.D1.E2 (habitat F5.51) or A11/A3.A5 (habitat I1.3)

**Temporal relations:**

- **Class phenology:** Perennial

**CLASS ATTRIBUTES:**

**Cover:** closed 90-100%

Class **Photometric/Phenological attributes:**

- **T1\_4 June-September:** green-yellow/green (peak of biomass in June-September)
- **T1\_5 October-May:** yellow

**Geometric attributes:**

- **Shape:** linear

**Morphological attributes:** None (or not relevant)

**Textural attributes:** None (or not relevant)

D5.2 VHR land cover maps

***EDGE ATTRIBUTES*** (if any):

**Additional info:** None (or not relevant)

**Conservation Status:** None (or not relevant)

**Class: A24/A2.A5.E6**

<p>13</p>	<p><b>NODE:A24/A2.A5.E6+R2.O3+Ruppia_spp_Potamogeton_spp</b></p> <p>Natural and semi-natural aquatic or regularly flooded vegetation/ Herbaceous.Forbs.Perennial</p> <p><b>+Environmental Attribute:</b></p> <ul style="list-style-type: none"> <li>• <b>WATER QUALITY:</b> Brackish water (R2)</li> <li>• <b>CLIMATE:</b> Subtropics-Winter Rainfall (O3)</li> <li>• <b>LITHOLOGY:</b> no data</li> <li>• <b>SOIL SURFACE ASPECT:</b> no data</li> <li>• <b>SOIL SUBSURFACE ASPECT:</b> no data</li> </ul> <p><b>+Technical Attribute:</b> Ruppia spp.; Potamogeton spp.;</p> <p>This class corresponds to the habitat: 1150</p>  <p style="text-align: center;"><b>Picture taken on July 2007</b></p>	<p><b>Photometric:</b></p> <p><b>Summer(July-2005): QUICKBIRD (spatial resolution=2.4 m)</b></p> <ul style="list-style-type: none"> <li>○ <u>Foreground SIAM spectral categories.</u> <u>Vegetation:</u> 16 SHRWE, 22 ASHRBR MNIR, 23 ASHRBR LNIR</li> <li>○ <u>Background SIAM spectral categories:</u> <ul style="list-style-type: none"> <li>○ <u>Soil:</u> 40 DBBF</li> <li>○ <u>Water:</u> 50 DPWASH_LSC</li> </ul> </li> </ul> <p><b>Summer(June- 2009):QUICKBIRD (spatial resolution=2.4 m)</b></p> <ul style="list-style-type: none"> <li>○ <u>Foreground SIAM spectral categories.</u> <u>Vegetation :</u> 16 SHRWE, 23 ASHRBR LNIR, 24 ASHRBR VLNIR</li> <li>○ <u>Background SIAM spectral categories.</u> <ul style="list-style-type: none"> <li>○ <u>Soil:</u> 40 DBBF, 64 UN3_LSC</li> <li>○ <u>Water:</u> 50 DPWASH_LSC, 52 TWASH_LSC</li> </ul> </li> </ul> <p><b>Fall(October-2009):WORLDVIEW-2 (spatial resolution=2 m)</b></p> <ul style="list-style-type: none"> <li>○ <u>Foreground SIAM spectral categories:</u> <u>Vegetation:</u> 16 SHRWE, 17 SHV_WEDR</li> <li>○ <u>Background SIAM spectral categories:</u> <ul style="list-style-type: none"> <li>○ <u>Soil:</u> 39 DBBF</li> <li>○ <u>Water:</u> 50 DPWASH_LSC, 52 TWASH_LSC</li> </ul> </li> </ul> <p><b>Geometric attributes:</b></p> <ul style="list-style-type: none"> <li>• <b>Area:</b></li> <li>• <b>Perimeter:</b></li> <li>• <b>Length:</b></li> <li>• <b>Width:</b></li> <li>• <b>Shape:</b></li> </ul>
-----------	--	---



Picture taken on July 2007

**Short habitat description:**

No data

**EDGES:**

**Non - spatial relationships:**

Class (*IS A*) Natural and semi-natural aquatic or regularly flooded vegetation (**A24**)

Class **Foreground:**

- **Position:**
- **Centroid:**
- **Angle:**
- **Compactness:**
- **Rectangularity:**
- **Elongation:**
- **Straightness of boundaries:**
- **List of skeleton endpoints with attributes: position, angle, inter-endpoint distance**

**Morphological attributes:**

**Textural attributes:**

- **With Structure**
- **With no Structure**

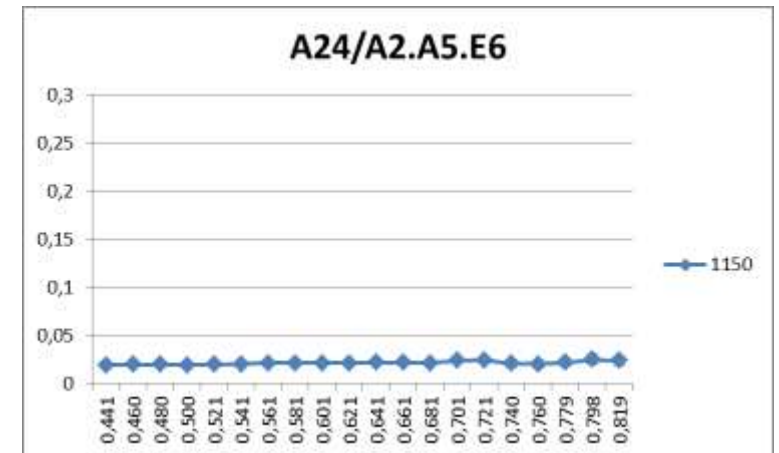

MIVIS VNIR Spectrum acquired on 24<sup>th</sup> May 2009  
(spatial resolution =3m)

## D5.2 VHR land cover maps

- **T1 June-September:** Herbaceous graminoid (**PART-OF**) (height depends on the water lagoon level).
- **T2 October-May:** Brackish water of coastal lagoon

### Class **Background:**

- **T1 June-September:** Brackish water of coastal lagoon (**PART-OF**)
- **T2 October-May:** Background coincides with Foreground

**Spatial-non topological relations:** None (or not relevant)

### **Spatial topological relations:**

- **Adjacent:**
  - **T3 November-April:**
    - **Towards the sandbank:** A24/A2.A6.E6 (habitat 1410);
    - **On the other side:** A24/A2.A6.E6 (habitat 1410) or A24/A2.A6.E6 (habitat D5.1) or A24/A2.A6.E6 (habitat D5.2)
  - **T4 May-October:**
    - **Towards the sandbank:** A24/A2.A5.E7 (habitat 1310) or A24/A2.A6.E6 (habitat 1410);
    - **On the other side:** A24/A2.A6.E6 (habitat 1410) A24/A2.A6.E6 (habitat D5.1) or A24/A2.A6.E6 (habitat 1410) or A24/A2.A6.E6 (habitat D5.2)

### **Temporal relations:**

- **Class phenology:** Perennial

### **CLASS ATTRIBUTES:**

**Cover:** from sparse 1-15% to open 15-25%

### Class **Photometric/Phenological attributes:**

- **T1 June-September:** green-light brown
- **T2 October-May:** no visible plants

D5.2 VHR land cover maps

**Geometric attributes:** None (or not relevant)

**Morphological attributes:** None (or not relevant)

**Textural attributes:** None (or not relevant)

***EDGE ATTRIBUTES*** (if any):

**Additional info:** None (or not relevant)

**Conservation Status:** None (or not relevant)

## D5.2 VHR land cover maps



**Class: B15/A1.A4.A13.A17**

17	<p><b>NODE: B15/A1.A4.13.A17</b></p> <p>Artificial Surfaces and associated areas/Built-up.Nonlinear.UrbanAreas.Scattered</p> <p><b>+Environmental Attribute:</b></p> <ul style="list-style-type: none"> <li>• <b>WATER QUALITY:</b> no data</li> <li>• <b>CLIMATE:</b> no data</li> <li>• <b>LITHOLOGY:</b> no data</li> <li>• <b>SOIL SURFACE ASPECT:</b> no data</li> <li>• <b>SOIL SUBSURFACE ASPECT:</b> no data</li> </ul> <p><b>+Technical Attribute:</b> no data</p> <p>This class corresponds to the habitat: Eunis J2.1</p> <p><b><u>Short habitat description:</u></b></p> <p>No data</p> <p><b>EDGES:</b></p> <p><b><u>Non - spatial relationships:</u></b></p> <p>Class (<b>IS A</b>) Artificial Surfaces and associated areas (<b>B15</b>)</p> <p>Class <b>Foreground:</b></p> <ul style="list-style-type: none"> <li>• Built up (<b>PART-OF</b>) (height &gt; 3 m)</li> </ul> <p>Class <b>Background:</b></p> <ul style="list-style-type: none"> <li>• Woody or herbaceous vegetation (<b>PART-OF</b>)</li> <li>• Shadow (depending on seasonality) (<b>PART-OF</b>)</li> </ul> <p><b><u>Spatial-non topological relations:</u></b></p>	<p><b>Photometric:</b></p> <p><b>Summer(July-2005): QUICKBIRD (spatial resolution=2.4 m)</b></p> <ul style="list-style-type: none"> <li>○ <u>Foreground SIAM spectral categories.</u> Built up/Soil: 32 BBB_TNCL, 34 SBBF, 35 SBBNF_LSC, 62 SN_CL_BBB_LSC</li> <li>○ <u>Background SIAM spectral categories.</u> Vegetation : 8 AVVH1NIR, 29 PB LSC</li> </ul> <p><b>Summer(June- 2009):QUICKBIRD (spatial resolution=2.4 m)</b></p> <ul style="list-style-type: none"> <li>○ <u>Foreground SIAM spectral categories.</u> Built up/Soil: 32 BBB_TNCL, 34 SBBF, 35 SBBNF_LSC, 38 ABBNF_LSC, 39 DBBVF, 41 DBBNF_LSC, 62 SN_CL_BBB_LSC</li> <li>○ <u>Background SIAM spectral categories.</u> Vegetation : 22 ASHRBR MNIR, 23 ASHRBR LNIR</li> </ul> <p><b>Fall(October-2009):WORLDVIEW-2 (spatial resolution=2 m)</b></p> <ul style="list-style-type: none"> <li>○ <u>Foreground SIAM spectral categories:</u> <ul style="list-style-type: none"> <li>○ <u>Built up/Soil:</u> 32 BBB_TNCL, 34 SBBF, 35 SBBNF_LSC, 36 ABBVF, 38 ABBNF_LSC, 62 SN_CL_BBB_LSC</li> <li>○ <u>Water:</u> 52 TWASH_LSC</li> </ul> </li> <li>○ <u>Background SIAM spectral categories.</u> Vegetation : 21 ASHRBR HNIR, 22 ASHRBR MNIR, 23 ASHRBR LNIR</li> </ul> <p>The patches are too small to obtain a representative MIVIS VNIR spectrum.</p> <p><b><u>Geometric attributes:</u></b></p> <ul style="list-style-type: none"> <li>• <b>Area:</b></li> <li>• <b>Perimeter:</b></li> </ul>
----	---	--

## D5.2 VHR land cover maps

- Isolated buildings\_

**Spatial topological relations:** no data

**Temporal relations:** no data

***CLASS ATTRIBUTES:***

**Cover:** scattered

Class **Photometric attributes:** white-brown-grey

**Geometric attributes:**

- **Shape:** regular

**Morphological attributes:** None (or not relevant)

**Textural attributes:** None (or not relevant)

***EDGE ATTRIBUTES*** (if any):

**Additional info:** None (or not relevant)

**Conservation Status:** None (or not relevant)

- **Length:**
- **Width:**
- **Shape:**
- **Position:**
- **Centroid:**
- **Angle:**
- **Compactness:**
- **Rectangularity:**
- **Elongation:**
- **Straightness of boundaries:**
- **List of skeleton endpoints with attributes: position, angle, inter-endpoint distance**

**Morphological attributes:**

**Textural attributes:**

- **With Structure**
- **With no Structure**

## D5.2 VHR land cover maps

**Class: B15/A1.A3.A7.A8**

<p>18</p>	<p><b>NODE: B15/A1.A3.A7.A8</b>                  Artificial Surfaces and associated areas/ Built-up.Linear.Roads.Paved</p> <p><b>+Environmental Attribute:</b></p> <ul style="list-style-type: none"> <li>• <b>WATER QUALITY:</b> no data</li> <li>• <b>CLIMATE:</b> no data</li> <li>• <b>LITHOLOGY:</b> no data</li> <li>• <b>SOIL SURFACE ASPECT:</b> no data</li> <li>• <b>SOIL SUBSURFACE ASPECT:</b> no data</li> </ul> <p><b>+Technical Attribute:</b> no data</p> <p>This class corresponds to the habitat: Eunis J4.2</p> <p><b><u>Short habitat description:</u></b></p> <p>No data</p> <p><b><u>EDGES:</u></b></p> <p><b><u>Non - spatial relationships:</u></b></p> <p>Class (<b>IS A</b>) Artificial Surfaces and associated areas (<b>B15</b>)</p> <p>Class <b>Foreground:</b></p> <ul style="list-style-type: none"> <li>• roads (<b>PART-OF</b>)</li> </ul> <p>Class <b>Background:</b></p> <ul style="list-style-type: none"> <li>• Woody or herbaceous vegetation (<b>PART-OF</b>)</li> </ul> <p><b><u>Spatial-non topological relations:</u></b></p>	<p><b>Photometric:</b></p> <p><b>Summer(July-2005): QUICKBIRD (spatial resolution=2.4 m)</b></p> <ul style="list-style-type: none"> <li>○ <u>Foreground SIAM spectral categories.</u> <u>Built up/Soil:</u>32 BBB_TNCL, 33 SBBVF_LSC,34 SBBF, 35 SBBNF_LSC, 36 ABBVF, 38 ABBNF_LSC, 39 DBBVF, 62 SN_CL_BBB_LSC</li> <li>○ <u>Background SIAM spectral categories.</u> <u>Vegetation :</u> 21 ASHRBR HNIR, 22 ASHRBR MNIR, 23 ASHRBR LNIR, 29 PB LSC</li> </ul> <p><b>Summer(June- 2009):QUICKBIRD (spatial resolution=2.4 m)</b></p> <ul style="list-style-type: none"> <li>○ <u>Foreground SIAM spectral categories.</u> <u>Built up/Soil:</u> 32 BBB_TNCL, 35 SBBNF_LSC, 36 ABBVF, 37 ABBF, 38 ABBNF_LSC, 39 DBBVF</li> <li>○ <u>Background SIAM spectral categories.</u> <u>Vegetation :</u> 22 ASHRBR MNIR, 23 ASHRBR LNIR, 24 ASHRBR VLNIR</li> </ul> <p><b>Fall(October-2009):WORLDVIEW-2 (spatial resolution=2 m)</b></p> <ul style="list-style-type: none"> <li>○ <u>Foreground SIAM spectral categories:</u> <ul style="list-style-type: none"> <li>○ <u>Built up/Soil:</u> 33 SBBVF_LSC, 35 SBBNF_LSC, 36 ABBVF, 38 ABBNF_LSC, 39 DBBVF, 62 SN_CL_BBB_LSC</li> <li>○ <u>Water:</u> 52 TWASH_LSC</li> </ul> </li> <li>○ <u>Background SIAM spectral categories:</u> <u>Vegetation :</u> 16 SHRWE, 17 SHV_WEDR, 21 ASHRBR HNIR, 22 ASHRBR MNIR, 23 ASHRBR LNIR, 24 ASHRBR VLNIR</li> </ul> <p>The patches are too small to obtain a representative MIVIS VNIR spectrum.</p>
-----------	---	---

## D5.2 VHR land cover maps

- Road network or country roads

**Spatial topological relations:** no data

**Temporal relations:** no data

***CLASS ATTRIBUTES:***

**Cover:** low density

Class **Photometric attributes:** beige –grey

**Geometric attributes:**

- **Shape:** regular

**Morphological attributes:** None (or not relevant)

**Textural attributes:** None (or not relevant)

***EDGE ATTRIBUTES*** (if any):

**Additional info:** None (or not relevant)

**Conservation Status:** None (or not relevant)

**Geometric attributes:**

- **Area:**
- **Perimeter:**
- **Length:**
- **Width:**
- **Shape:**
- **Position:**
- **Centroid:**
- **Angle:**
- **Compactness:**
- **Rectangularity:**
- **Elongation:**
- **Straightness of boundaries:**
- **List of skeleton endpoints with attributes:** position, angle, inter-endpoint distance

**Morphological attributes:**

**Textural attributes:**

- **With Structure**
- **With no Structure**

## Illustrations of different contacts for some habitats

**Figure 3: Contacts for Habitat: Sea → Landwards**

**This is an ideal synthesized situation**

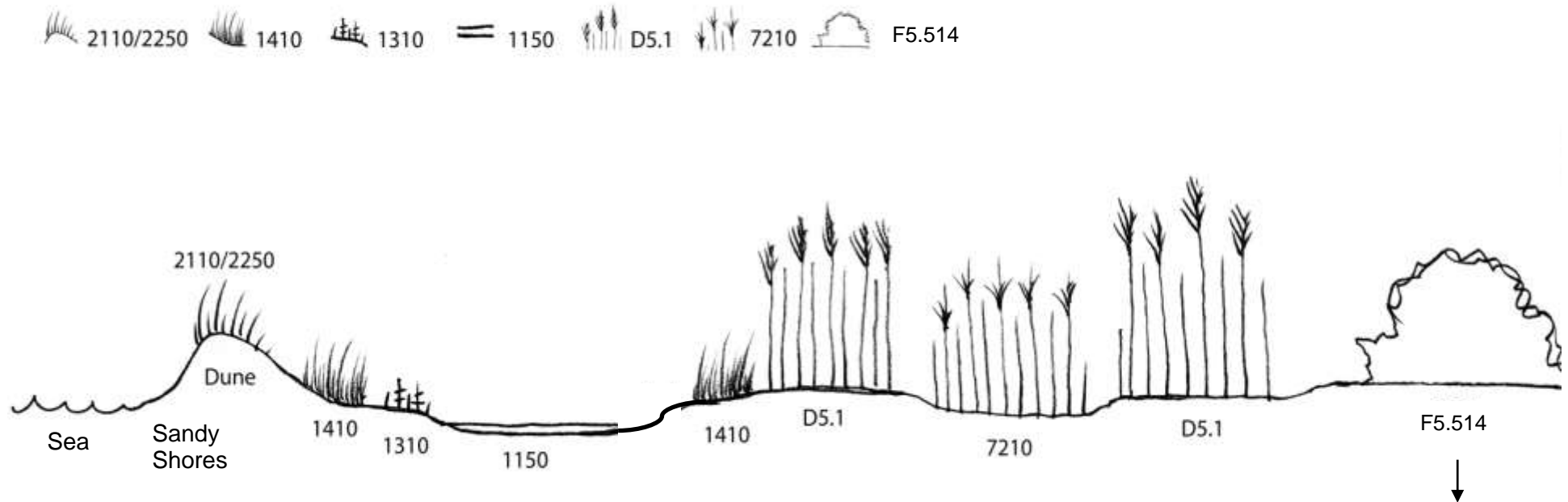

- The presence of habitat 1310 next to 1150 (lagoon) is detectable in a saline water environment during the summer season whereas in a fresh water environment or in winter season there are the habitat 1410 or D5.1 directly;
- Habitat 7210 is detectable only in a fresh water environment (in this case due to a water table). The scheme is referred to the contacts for habitat 7210 which in presence of salt/brackish lagoons is in the landwards;
- “or” means presence of different combinations of the indicated habitats depending on their location in the test site (see Figure 3.1-3.2-3.3-3.4 which show the actual sequence of habitat types along four different transects in the IT4 test site).

↓  
or  
**G3.F1**  
or  
**G2.91**

Figure 3.1: Position of different transects illustrating the actual sequence of habitat types in the IT4 test site

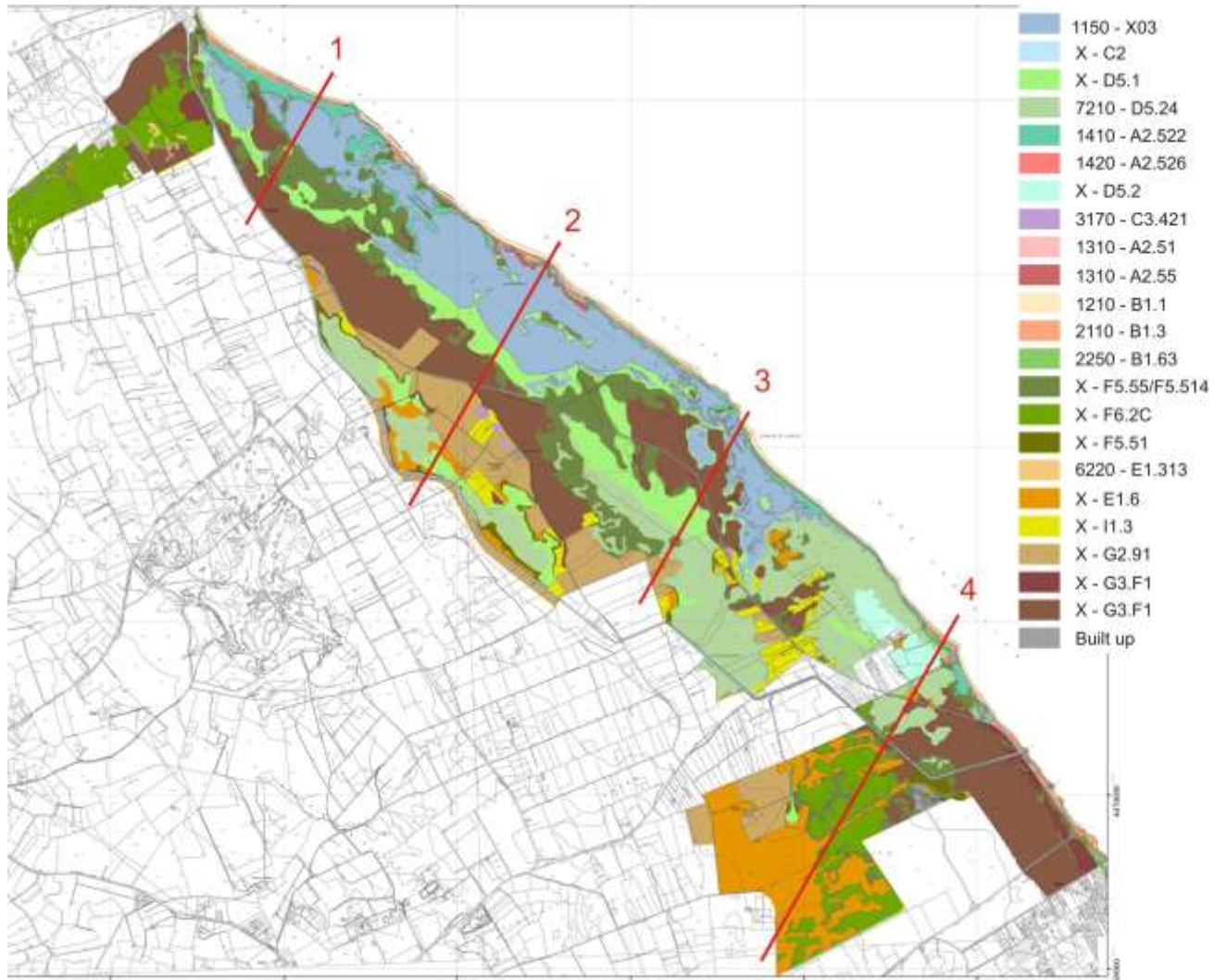
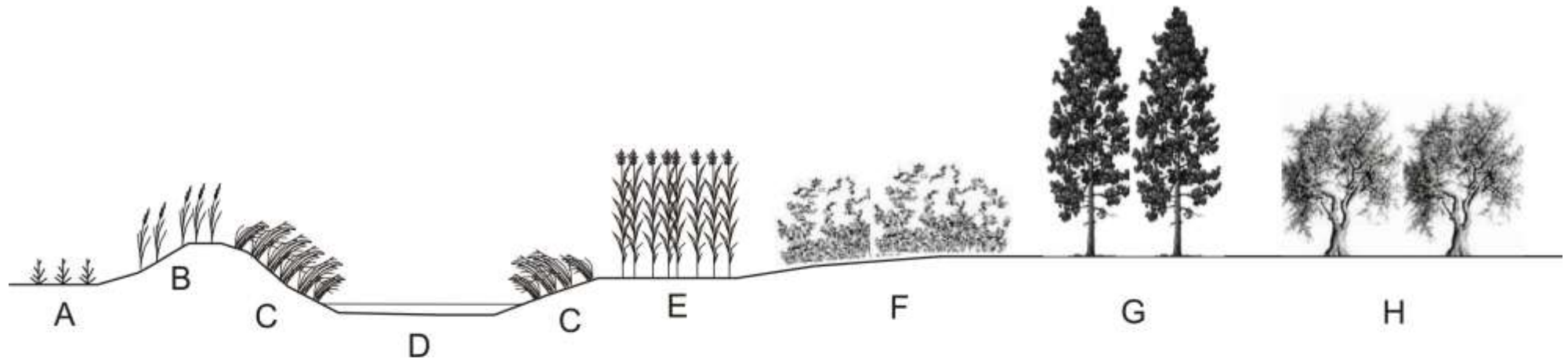

Figure 3.2: Detail of the transect 1

# TRANSECT 1

Sea ← → Landwards



A: 1210 - B1.1

B: 2110 - B1.3

C: 1410 - A2.522

D: 1150 - X03

E: X - D5.1

F: X - F5.514

G: X - G3.F1

H: X - G2.91

- The illustrating sequence of habitats is referred to the red line of transect 1 drawn in Figure 3.1.
- This sequence can be generalized in a zone ranging from the top of the boundary of IT4 site to the beginning of the 1310 habitat (where the salinization occurs).
- The landwards habitats could change due to the land use.



Figure 3.3: Detail of the transect 2

# TRANSECT 2

Sea ← → Landwards

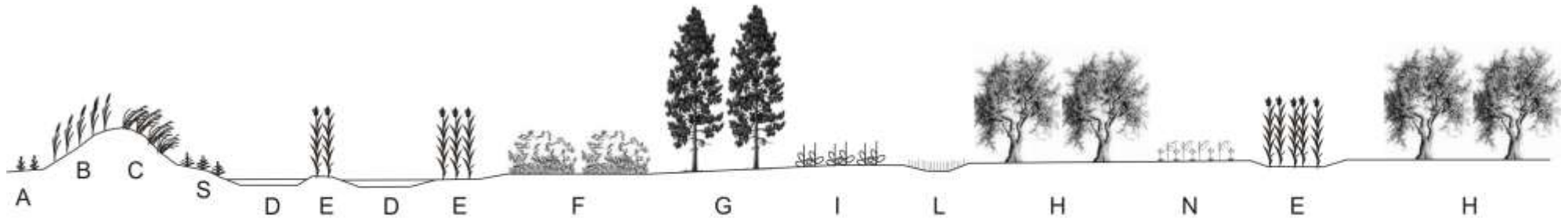

A: 1210 - B1.1

B: 2110 - B1.3

C: 1410 - A2.522

S: 1310 - A2.55

D: 1150 - X03

E: X - D5.1

F: X - F5.514

G: X - G3.F1

I: X - I1.3

L: 3170 - C3.421

H: X - G2.91

N: X - E1.6

- The illustrating sequence of habitats is referred to the red line of transect 2 drawn in Figure 3.1.
- This sequence can be generalized in a zone ranging from the beginning of the 1310 habitat (where the salinization occurs) to the end of the 1310 habitat.
- The landwards habitats could change due to the land use.

Figure 3.4: Detail of the transect 3

# TRANSECT 3

Sea ← → Landwards

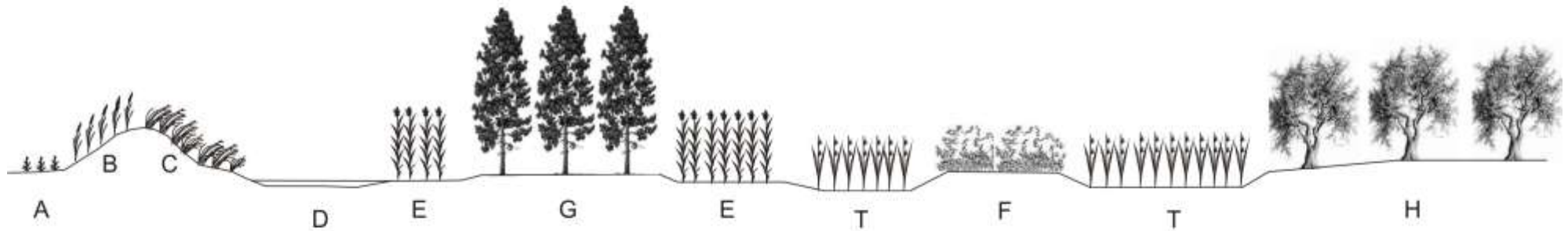

A: 1210 - B1.1

B: 2110 - B1.3

C: 1410 - A2.522

D: 1150 - X03

E: X - D5.1

G: X - G3.F1

T: 7210 - D5.24

F: X - F5.514

H: X - G2.91

- The illustrating sequence of habitats is referred to the red line of transect 3 drawn in Figure 3.1.
- This sequence can be generalized in a zone ranging from the end of the 1310 habitat (where the salinization occurs) to the end of the coastal lagoon.
- The landwards habitats could change due to the land use.

D5.2 VHR land cover maps  
Figure 3.5: Detail of the transect 4

## TRANSECT 4

Sea ← → Landwards



A: 1210 - B1.1

B: 2110 - B1.3

R: 2250 - B1.63

C: 1410 - A2.522

T: 7210 - D5.24

F: X - F5.514

N: X - E1.6

Q: X - F6.2C

- The illustrating sequence of habitats is referred to the red line of transect 4 drawn in Figure 3.1.
- This sequence can be generalized in a zone ranging from the end of the coastal lagoon to the end of the 7210 habitat.
- The landwards habitats could change due to the land use.

Figure 4: Contacts for Series of Sandy Shores (no disturb): zoom of the sandy shore 2110/2250 of Figure 3

This is an ideal synthesized situation

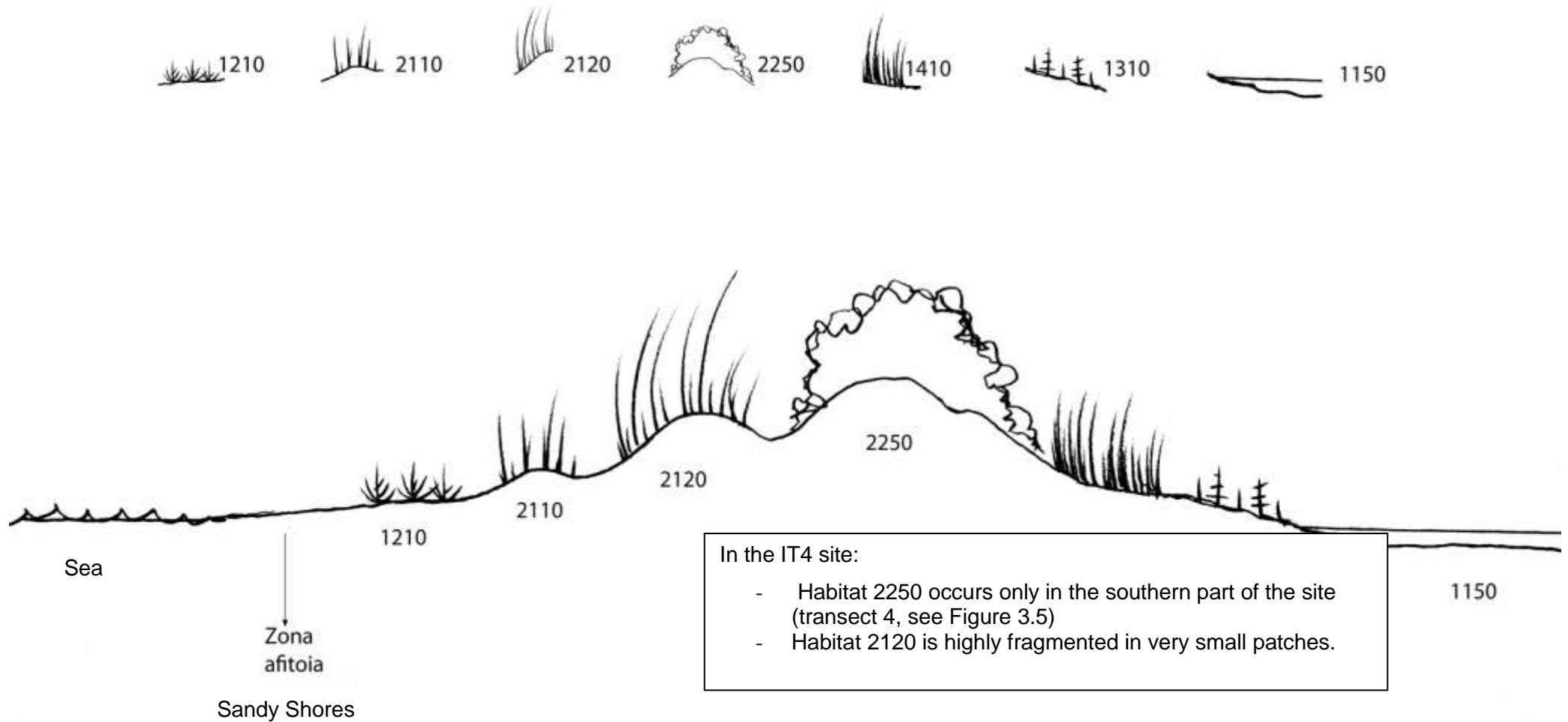

**Figure 5: Contacts for Habitat 7210 in absence of salt/brackish water**

**This is an ideal synthesized situation**

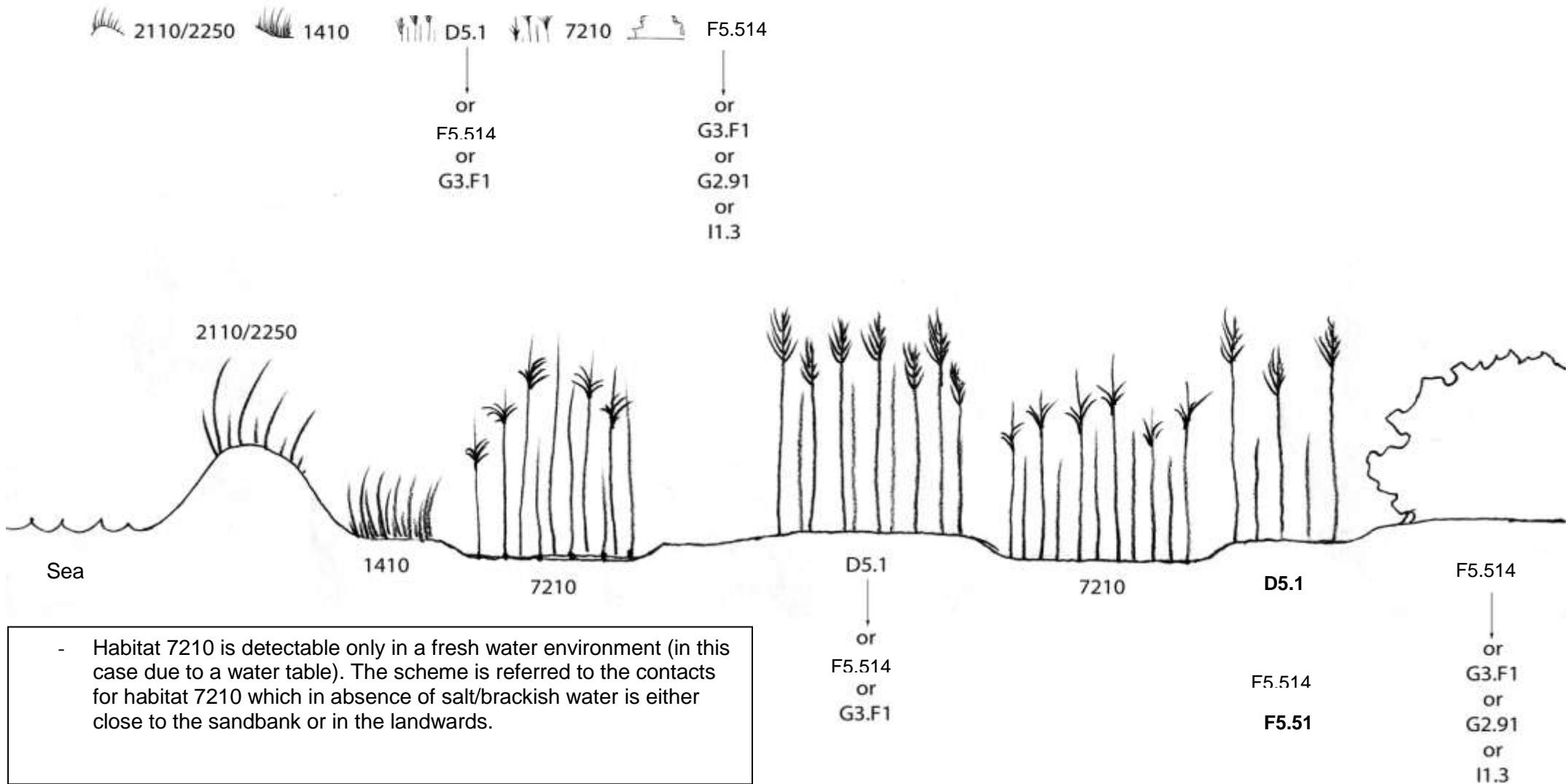

## D5.2 VHR land cover maps

## B2. Class description for Greek sites

### B2.1 GR1 site

#### LC Classes – Seasonal Phenological characteristics

LCCS	HABITAT	JAN	FEB	MAR	APR	MAY	JUN	JUL	AGO	SEP	OCT	NOV	DEC
A11/A3.A4.D3	1020												
B15/A1.A4.A13.A16	1050												
B28/A1.D2	1130												
A24/A2.A5.E5	1150												
A12/A2.A5.E5	1210												
A24/A2.A5.E7	1310												
A24/A2.A6.E5	1410												
A24/A1.A4.D3	1420												
A12/A2.A6.E6	2110												
A24/A2.A5.E5	3280												
A12/A1.A4.D1.E1	5330												
A12/ A1.A4.D1.E2.F1	5340 (F6.2)												
A12/A1.A4.C1	5420												
A12/A2.A6.C2.E5	6420												
A24/A2.A6.C3	72 A0 (A2.53)												
A12/A1.A3.D1.E1.F1	92 A0												
A12/A1.A4.B3	92D0												
A12/A1.A3.D1.E2.F1	9350												

	Dense vegetation and/or peak of biomass
	Sparse (younger) vegetation or minor green biomass
	Minor biomass with withered/dry plants (or part of plants)
	Bare soils (or water in A24) with remnants of withered/dry plants

D5.2 VHR land cover maps

Figure 1: LC Classes for GR1 test site- Seasonal Phenological characteristics

**LC Classes – Seasonal Water Coverage**

LCCS	HABITAT	JAN	FEB	MAR	APR	MAY	JUN	JUL	AGO	SEP	OCT	NOV	DEC
A11/A3.A4.D3	1020												
B15/A1.A4.A13.A16	1050												
B28/A1.D2	1130												
A24/A2.A5.E5	1150												
A12/A2.A5.E5	1210												
A24/A2.A5.E7	1310												
A24/A2.A6.E5	1410												
A24/A1.A4.D3	1420												
A12/A2.A6.E6	2110												
A24/A2.A5.E5	3280												
A12/A1.A4.D1.E1	5330												
A12/ A1.A4.D1.E2.F1	5340 (F6.2)												
A12/A1.A4.C1	5420												
A12/A2.A6.C2.E5	6420												
A24/A2.A6.C3	72 A0 (A2.53)												
A12/A1.A3.D1.E1.F1	92 A0												
A12/A1.A4.B3	92D0												
A12/A1.A3.D1.E2.F1	9350												

	Water
	Wet or waterlogged soil
	Dry (at the surface) soil

Figure 2: LC Classes for GR1 test site- Seasonal Water Coverage



**Class: B28/A1.D2**

**NODE: B28/A1B1C2D2-A4**

Natural waterbodies/ Estuaries

**+Environmental Attribute:**

- **WATER QUALITY:** Saline/brackish water (R2/R3)
- **CLIMATE:** Subtropics-Winter Rainfall (O3)
- **LITHOLOGY:** Unconsolid-clastic sedimentary rock-sand (M213)
- **SOIL SURFACE ASPECT:** no data
- **SOIL SUBSURFACE ASPECT:** no data

**+Technical Attribute:** *Zostera maritima*;

This class corresponds to the habitat: 1130

**Short habitat description:**

Natural waterbodies - Turbid Shallow Perennial Natural Waterbodies (Flowing)

---

**Class: A24/A2.A5.E5**

**NODE: A24/ A2.A5.A13.B4.C1.E5.F1.-A15.B12.E6**

Natural and semi-natural aquatic or regularly flooded vegetation/ Herbaceous.Forbs.Perennial

**+Environmental Attribute:**

- **WATER QUALITY:** Brackish water (R2)
- **CLIMATE:** Subtropics-Winter Rainfall (O3)
- **LITHOLOGY:** no data
- **SOIL SURFACE ASPECT:** no data
- **SOIL SUBSURFACE ASPECT:** no data

**+Technical Attribute:** *Ruppia* spp.; *Potamogeton* spp.;

This class corresponds to the habitat: 1150

**Short habitat description:**

Adjacent to habitats 1410 (A24/A2.A6.E6), 1420 (A24/A1.A4.D3), 5330 (A12/A1.A4.D1.E1), 1310 (A24/A2.A5.E7) and/or 5420 (A12/A1.A4.C1).

**Class: A12/A2.A5.E5**

**NODE:A12/A2A5A11B4XXE5-A13B13E7**

Natural and semi-natural terrestrial vegetation/Herbaceous.Forbs.Annual

**+Environmental Attribute:**

- **WATER QUALITY:** none
- **CLIMATE:** Subtropics-Winter Rainfall (O3)
- **LITHOLOGY:** Calcareous rock-calcarenite (M233)
- **SOIL SURFACE ASPECT:** Loose and shifting sands (N3)
- **SOIL SUBSURFACE ASPECT:** Arenosols (N12-AR)

**+Technical Attribute:** *Cakile maritima*

This class corresponds to the habitat: 1210

**Short habitat description:**

Terrestrial natural areas – herbaceous annual vegetation of non graminoid plants with vegetative cycle (green plants) from April (May) to August. Sand beach annual communities (*Cakiletea maritimi*)

This is the first vegetated area, along the sandy shores, next to the coast-line and forming a strip parallel to the coastline.

Low density (low-medium cover)

Adjacent to the tidal zone towards the sea, and adjacent to the habitats 1150 (A24/A2.A5.E5), 1420 (A24/A1.A4.D3), 2110 (A12/A2.A6.E6), 6420 (A12/A2.A6.C2.E5) and 5420 (A12/A1.A4.C1) towards the inland.

Sandy shores – sand (background).

---

**Class: A12/A2.A6.E6**

**NODE:A12/A2.A6.A11.B4.XX.E5.-A12.B12.E6**

Natural and semi-natural terrestrial vegetation/Herbaceous.Graminoid.Perennial

## D5.2 VHR land cover maps

### +Environmental Attribute:

- **WATER QUALITY:** none
- **CLIMATE:** Subtropics-Winter Rainfall (**O3**)
- **LITHOLOGY:** Unconsolidated-clastic sedimentary rock-sand (**M213**)
- **SOIL SURFACE ASPECT:** Loose and shifting sands, with dunes (**N7**)
- **SOIL SUBSURFACE ASPECT:** Arenosols (**N12-AR**)

+Technical Attribute: *Agropyron junceum*

This class corresponds to the habitat: 2110

### Short habitat description:

Terrestrial natural areas – herbaceous perennial vegetation of graminoid plants (cespitous hemicriptophytes). Open ((70-60) - 40%) Perennial Medium Tall Grassland Distributed along the sandy shores, usually arranged in an elongated shape, forming a more or less continuous strip (width > 1,5 m) parallel to the coastline.

Low density (low-medium cover)

Adjacent to habitat 1210 (A12/A2.A5.E7) towards the sea.

Sandy shores – embryo dunes - sand (background).

---

## Class: A24/A2.A5.E7

### **NODE: A24/A2.A5.A13.B4.C2.E5.-B13.E7**

Natural and semi-natural aquatic or regularly flooded vegetation/ Salt marshes

### +Environmental Attribute:

- **WATER QUALITY:** Saline/brackish water (**R3/R2**)
- **CLIMATE:** Subtropics-Winter Rainfall (**O3**)
- **LITHOLOGY:** Unconsolidated-clastic sedimentary rock-sand (**M213**)
- **SOIL SURFACE ASPECT:** Soil Surface (**N2**)
- **SOIL SUBSURFACE ASPECT:** Solonchak (**N12-SC**)

+Technical Attribute: *Salicornia* spp.; *Suaeda* spp.; *Parapholis* spp. or annuals of *Thero-Salicornietea* and/or *Saginetea maritimae*

It corresponds to **Habitat:** 1310 (Eunis: A2.51 or A2.55 (see D5.1))

## D5.2 VHR land cover maps

### **Short habitat description:**

Aquatic natural areas – Salicornia and other annuals colonizing mud and sand. Herbaceous annual vegetation of non graminoid plants, composed mostly of annual glassworts (height 0,2-0,4 m) colonising periodically inundated muds of coastal saltmarshes - vegetative cycle from June to October (greyish green to reddish green) with maximum biomass in August-September.

This vegetation, during its vegetative cycle, usually forms a belt (width > 1 to 10 m) around the coastal lagoons. In this case, it does not come to form a belt, but strips (elongated patches) along the edge of the lagoon (on the sea side).

In winter (from November to March) the area is flooded by the salt or brackish waters of the lagoon. In spring (April-May), water tends to dry up and recede, leaving out the substrate (mud or sands) of the edges of the lagoon. In summer (starting from May-June) the young plants emerge in this area, initially in an sparse coverage and then thickening in July-October.

Adjacent to habitat 1150 (A24/A2.A5.E6) 1420 (A24/A1.A4.D3) and/or 5420 (A12/A1.A4.C1).

Density: from low (May-June) to medium-high (September) according to the month of observation.

Mud or sand as background.

---

### **Class: A24/A2.A6.E5**

#### **NODE: A24/ A2.A6.A12.B4.C2.E5.-B11.E6**

Natural and semi-natural aquatic or regularly flooded vegetation/ Herbaceous.Graminoid.Perennial

#### **+Environmental Attribute:**

- **WATER QUALITY:** Saline/brackish water (R2/R3)
- **CLIMATE:** Subtropics-Winter Rainfall (O3)
- **LITHOLOGY:** Unconsolid-clastic sedimentary rock-sand(M213)
- **SOIL SURFACE ASPECT:** no data
- **SOIL SUBSURFACE ASPECT:** Solonchak (N12-SC)

**+Technical Attribute:** *Juncus* spp.; *Carex* spp.; *Plantago crassifolia*; or perennial species of *Juncetea maritimi*

This class corresponds to the habitat: 1410

### **Short habitat description:**

## D5.2 VHR land cover maps

Aquatic natural areas – Mediterranean salt meadows (*Juncetalia maritimi*). Herbaceous perennial vegetation of graminoid plants, composed mostly of sedges, rushes and reeds (height 0,8-2 m) colonising periodically inundated muds of coastal saltmarshes – This vegetation has a maximum of biomass (greyish-brownish green ) in June-September and minor biomass with dry plants (most of the aerial part) in the rest of the year.

Generally this habitat is located in proximity (around) of water bodies, coastal lagoons with salt or brackish waters.

The background is water or waterlogged soil in winter (November-March), moist soil in spring, sand or mud in summer.

Polygons of this vegetation unit at the western part of this site are adjacent to habitat 72A0 (A24/A2.A6.C3), 1420 (A24/A1.A4.D3), 1150 (A24/A2.A5.E6) and/or 92D0 (A12/A1.A4.B3).

High density.

---

### Class: A24/A1.A4.D3

#### **NODE: A24/ A1.A4.A12.B3.C2.D3.-B10**

Natural and semi-natural aquatic or regularly flooded vegetation/Woody.Shrubs. Aphyllous

##### **+Environmental Attribute:**

- **WATER QUALITY:** Saline/brackish water (R2/R3)
- **CLIMATE:** Subtropics-Winter Rainfall (O3)
- **LITHOLOGY:** Unconsolidated-clastic sedimentary rock-sand(M213)
- **SOIL SURFACE ASPECT:** no data
- **SOIL SUBSURFACE ASPECT:** Solonchak (N12-SC)

**+Technical Attribute:** *Sarcocornia* spp.; *Suaeda vera*; *Arthrocnemum* spp. or perennial species of *Sarcocornietea*

This class corresponds to the habitat: 1420

#### **Short habitat description:**

Aquatic natural areas – Saltmarsh scrubs (*Arthrocnemetea fruticosi*). Woody vegetation of perennial halophytes, mainly succulent chamaephytes and nanophanerophytes (height 0,5-1 m) colonising saline marine muds (coastal saltmarshes) – this vegetation shows a peak of biomass (greyish green) from June to September.

Generally this habitat is located in proximity (around) of coastal lagoons with saline waters.

In winter the background is water lagoon (November-March) or waterlogged soil, in spring (April-May) the background is wet soil, in summer (June-October) the background is dried soil on the surface.

## D5.2 VHR land cover maps

Polygons of this vegetation unit at the western part of this site are surrounded by or are adjacent to habitat 72A0 (A24/A2.A6.C3) and in one case also adjacent to 92D0 (A12/A1.A4.B3). At the northern part of the site, polygons of this habitat type are surrounded by 92D0 and at the southern part of the site there is one polygon adjacent to 92D0 (A12/A1.A4.B3) and 1150 (A24/A2.A5.E6).

Low to medium-high density

Presence of this habitat indicates salt water (salinisation).

---

### Class: A24/A2.A5.E5

**NODE: A24/A2A5A13B4C3XXE5F2F5F10G2F1-A8A15B11E6G7**

Natural and semi natural aquatic or regularly flooded vegetation / Inland marshes

**+Environmental Attribute:**

- **WATER QUALITY:** Fresh water (R1)
- **CLIMATE:** Subtropics-Winter Rainfall (O3)
- **LITHOLOGY:** Calcareous rock-calcareenite (M233)
- **SOIL SURFACE ASPECT:** no data
- **SOIL SUBSURFACE ASPECT:** Histosols (N12-HS)

**+Technical Attribute:** Paspalum distichum, Salix alba- Populus alba

This class corresponds to the habitat: 3280

**Short habitat description:**

Natural aquatic or regularly flooded vegetation. Natural waterbodies. Perennial open (40 - (20-10)%) tall rooted forbs with low emergents on waterlogged soil.

Presence of sand or outcropping calcareous rocks as background.

Adjacent to habitat 92A0 (A12/A1.A3.D1.E1.F1) or 1020 (A11/A3.A4.D3).

Distributed next to the riverline, in a band of variable width, from a few to several hundred meters, based on the geomorphology of the belt.

## Class: A12/A1.A4.D1.E1

### **NODE:A12/A1A4A10B3XXD1E1F1-B9**

Natural and semi-natural terrestrial vegetation/Woody.Shrubs.Broadleaved.Evergreen

#### **+Environmental Attribute:**

- **WATER QUALITY:** none
- **CLIMATE:** Subtropics-Winter Rainfall (**O3**)
- **LITHOLOGY:** Unconsolid-clastic sedimentary rock-sand(**M213**)
- **SOIL SURFACE ASPECT:** none
- **SOIL SUBSURFACE ASPECT:** Leptosols (**N12-LP**)

**+Technical Attribute:** *Euphorbia dendroides* formations

This class corresponds to the habitat: 5330

#### **Short habitat description:**

Terrestrial natural areas – Tree-spurge formations - Thermo-mediterranean broom fields ([retamares])

High density (high cover)

Presence of sand or outcropping calcareous rocks as background.

At the south part of the site, surrounded by the habitat 5420 (A12/A1.A4.C1).

Distributed next to the coastline, in a band of variable width, from a few to several hundred meters, based on the geomorphology of the coastal belt.

---

## Class: A12/A1.A4.D1.E2.F1

### **NODE:A12/ A1A4A11B3XXD1E2F1-A12B9**

Natural and semi-natural terrestrial vegetation/ Sclerophyllous vegetation

#### **+Environmental Attribute:**

- **WATER QUALITY:** none
- **CLIMATE:** Subtropics-Winter Rainfall (**O3**)
- **LITHOLOGY:** Unconsolid-clastic sedimentary rock-sand(**M213**)
- **SOIL SURFACE ASPECT:** Stony 5-40% (**N4**)

## D5.2 VHR land cover maps

- **SOIL SUBSURFACE ASPECT:**

**+Technical Attribute:**

This class corresponds to the habitat: 5340 (F6.2)

**Short habitat description:**

Terrestrial natural areas –woody vegetation characterized by broadleaved deciduous ((70-60) - 40%) medium-high sclerophyllous shrubs - height 0,8-2 m.

High density (high cover)

There are many (nine) different polygons of this habitat type at the southern half of this site. Three of them are surrounded by habitat 1020 (A11/A3.A4.D3) while the others are adjacent to habitats 1020 as well as 5420(A12/A1.A4.C1), or 1420 (A24/A1.A4.D3) and 1150 (A24/A2.A5.E6), or 1410 (A24/A2.A6.E5).

---

### **Class: A12/A1.A4.C1**

**NODE: A12/A1A4A11B3C1XXXXF1-A12B9**

Natural and semi-natural terrestrial vegetation/Open shrublands

**+Environmental Attribute:**

- **WATER QUALITY:** none
- **CLIMATE:** Subtropics-Winter Rainfall (**O3**)
- **LITHOLOGY:** Sedimentary rock (**M2**)
- **SOIL SURFACE ASPECT:** Stony 5-40% (**N4**)
- **SOIL SUBSURFACE ASPECT:**

**+Technical Attribute:** Cisto-Micromerietea (-etalia)

This class corresponds to the habitat: 5420

**Short habitat description:**

Terrestrial natural areas – Open ((70-60) - 40%) medium-high shrubland woody vegetation

Medium density (medium cover)

Present in a number of different polygons. All polygons except the southernmost one are adjacent to habitat 1020(A11/A3.A4.D3). The northern polygon and the central ones are surrounding a polygon of habitat 9350 (A12/A1.A3.D1.E2.F1) and are also adjacent to habitats 92D0 (A12/A1.A4.B3) (the northern one) as well as 92D0, 1420(A24/A1.A4.D3) and 1050 (B15/A1.A4.A13.A16) (the central one). The smaller of the two south-eastern polygons is surrounded by



## D5.2 VHR land cover maps

habitat 1020 while the other one is adjacent to 1020, 5340 and 1420. The southernmost one is adjacent to habitats 72A0 (A24/A2.A6.C3), 5330 (A12/A1.A4.D1.E1) and 1150 (A24/A2.A5.E6).

---

### Class: A12/A2.A6.C2.E5

#### **NODE: A12/A2A6A11B4C2E5-A12B11E6**

Natural and semi-natural terrestrial vegetation/ Natural grasslands

#### **+Environmental Attribute:**

- **WATER QUALITY:** none
- **CLIMATE:** Subtropics-Winter Rainfall (**O3**)
- **LITHOLOGY:** Sedimentary rock (**M2**)
- **SOIL SURFACE ASPECT:** Stony 5-40% (**N4**)
- **SOIL SUBSURFACE ASPECT:**

**+Technical Attribute:** Scirpoides holoschoenus

This class corresponds to the habitat: 6420

#### **Short habitat description:**

Terrestrial natural areas – Interrupted open ((70-60) - 40%) perennial tall grassland

This vegetation is adjacent with habitats 1310 (A24/A2.A5.E7) and 72A0 (A24/A2.A6.C3).

---

### Class: A24/A2.A6.C3

#### **NODE: A24/A2A6A12B4C3-B11**

Natural and semi-natural aquatic or regularly flooded vegetation/ Grasslands

#### **+Environmental Attribute:**

- **WATER QUALITY:** Fresh water (**R1**)
- **CLIMATE:** Subtropics-Winter Rainfall (**O3**)
- **LITHOLOGY:** Calcareous rock-calcarenite (**M233**)

## D5.2 VHR land cover maps

- **SOIL SURFACE ASPECT:** no data
- **SOIL SUBSURFACE ASPECT:** Histosols (**N12-HS**)

+**Technical Attribute:** *Phragmites australis*, *Bolboschoenus maritimus*

This class corresponds to the habitat: 72A0

### **Short habitat description:**

Aquatic natural areas – Intertidal flats. Reed thickets (*Phragmites australis*). Closed Tall Grassland On Waterlogged Soil.

The background is water or waterlogged soil in winter (November-March), moist soil or waterlogged soil in spring, (moist) sand or mud in summer. High density.

This vegetation is adjacent to habitat 1410 (A24/A2.A6.E6) at the northern part of the site, to habitats 92D0 (A12/A1.A4.B3), 5420 (A12/A1.A4.C1) and 1420 (A24/A1.A4.D3) at the central-western part and to habitats 1420 (A24/A1.A4.D3), 5420 (A12/A1.A4.C1) and 1210 (A12/A2.A5.E7) at the southern part of the site.

---

## **Class: A12/A1.A3.D1.E1.F1**

**NODE: A12/A1A3A10B2XXD1E1F1-B7**

Natural and semi natural primarily terrestrial vegetation/ Deciduous Broadleaf Forests

+**Environmental Attribute:**

- **WATER QUALITY:** none
- **CLIMATE:** Subtropics-Winter Rainfall (**O3**)
- **LITHOLOGY:** Sedimentary rock (**M2**)
- **SOIL SURFACE ASPECT:** Stony 5-40% (**N4**)
- **SOIL SUBSURFACE ASPECT:** Histosols (**N12-HS**)

+**Technical Attribute:** *Salix alba*, *S. fragilis*, *Populus alba*, *Alnus* spp.

This class corresponds to the habitat: 92A0

### **Short habitat description:**

Natural primarily terrestrial vegetation. Broadleaved Deciduous High Trees, Single Layer. Seasonally wet/eutrophic.Riparian *Salix*, *Alnus* and *Betula* woodland on deep wet or waterlogged soil. Softwood forests of *Salix alba* and *Populus alba*.

This vegetation is adjacent to habitats 1020 (A11/A3.A4.D3), 1420 (A24/A1.A4.D3) and 92D0 (A12/A1.A4.B3).

### **Class: A12/A1.A4.B3**

#### **NODE: A12/A1A4A11B3-A12B14**

Natural and semi natural primarily terrestrial vegetation/ Open shrublands.

#### **+Environmental Attribute:**

- **WATER QUALITY:** none
- **CLIMATE:** Subtropics-Winter Rainfall (**O3**)
- **LITHOLOGY:** Sedimentary rock (**M2**)
- **SOIL SURFACE ASPECT:** Stony 5-40% (**N4**)
- **SOIL SUBSURFACE ASPECT:**

**+Technical Attribute:** *Nerium oleander*, *Tamarix* spp.

This class corresponds to the habitat: 92D0

#### **Short habitat description:**

Natural primarily terrestrial vegetation. Open ((70-60) - 40%) medium to high shrubs (shrubland) with *Tamarix hampeana*, *Tamarix parviflora*, *Tamarix smyrnensis*, *Tamarix tetrandra* as well as *Nerium oleander*, *Vitex agnus-castus* etc. on dry soils.

This vegetation is surrounded many different small polygons of the habitat 1420 (A24/A1.A4.D3) at the northern part of the site. Near the river, it is adjacent to habitat 92A0 (A12/A1.A3.D1.E1.F1) at the river side and to habitats 1410 (A24/A2.A6.E6) or 1420 (A24/A1.A4.D3) at the opposite part as well as to 72A0 (A24/A2.A6.C3). At the south western part of the site, this vegetation unit is adjacent to habitats 1020 (A11/A3.A4.D3), 1150 (A24/A2.A5.E5), 1410, 1420 and 72A0 for the larger polygon and 1020, 1410 and 92A0 for the smaller one. The southern of the polygons is adjacent to habitats 1420, 1020 and 1150.

---

### **Class: A12/A1.A3.D1.E2.F1**

#### **NODE: A12/A1A3A10B2XXD1E2F1-B7**

Natural and semi natural primarily terrestrial vegetation/ Deciduous Broadleaf Forests

#### **+Environmental Attribute:**

- **WATER QUALITY:** none
- **CLIMATE:** Subtropics-Winter Rainfall (**O3**)
- **LITHOLOGY:** Calcareous rock (**M230**)

## D5.2 VHR land cover maps

- **SOIL SURFACE ASPECT:** Stony 5-40% (N4)
- **SOIL SUBSURFACE ASPECT:**

+**Technical Attribute:** *Quercus macrolepis*

This class corresponds to the habitat: 9350

### **Short habitat description:**

Natural primarily terrestrial vegetation. Broadleaved Deciduous Low Trees, Single Layer. Mediterranean *Quercus macrolepis* woodland on dry soils.

This vegetation unit is represented in this site with two polygons, both surrounded by habitat 5420 (A12/A1.A4.C1).

---

## **Class: A11/A3.A4.D3**

**NODE: A11/A3A4B1XXC2D3-B4C3C7C19D5**

Cultivated and managed terrestrial areas/ Cropland

+**Environmental Attribute:**

- **WATER QUALITY:** none
- **CLIMATE:** Subtropics-Winter Rainfall (O3)
- **LITHOLOGY:**
- **SOIL SURFACE ASPECT:**
- **SOIL SUBSURFACE ASPECT:**

+**Technical Attribute:**

This class corresponds to the habitat: 1020

### **Short habitat description:**

Cultivated and managed terrestrial areas. Non irrigated arable land. Intensive unmixed crops. Sprinkler Irrigated Graminoid Crop(s) (One Additional Crop) (Herbaceous Terrestrial Crop Sequentially).

This habitat type covers a large area of this site and is adjacent to habitats 1410 (A24/A2.A6.E6), 1050 (B15/A1.A4.A13.A16), 92D0 A12/A1.A4.B3), 5420 (A12/A1.A4.C1), 92A0 (A12/A1.A3.D1.E1.F1), 5340 (A12/A1.A4.D1.E2.F1) and 72A0 (A24/A2.A6.C3).

**Class: B15/ A1.A4. A13.A16**

**NODE: B15/A1A4A13A16**

Artificial surfaces and associated areas/ Urban and built-up

**+Environmental Attribute:**

- **WATER QUALITY:** none
- **CLIMATE:** Subtropics-Winter Rainfall (O3)
- **LITHOLOGY:**
- **SOIL SURFACE ASPECT: SOIL SUBSURFACE ASPECT:**

**+Technical Attribute:**

This class corresponds to the habitat: 1050

**Short habitat description:**

Artificial surfaces and associated areas. Low Density Urban Area(s)

Polygons of this habitat type are all adjacent with habitat 1020 (A11/A3.A4.D3) while the northern one is also adjacent to 1410 (A24/A2.A6.E5), the central one is also adjacent to 5420 (A12/A1.A4.C1) and one of the southern polygons is also adjacent to 5340 (A12/A1.A4.D1.E2.F1).

**B2.2 GR2 site**

**LC Classes – Seasonal Phenological characteristics**

LCCS	HABITAT	JAN	FEB	MAR	APR	MAY	JUN	JUL	AGO	SEP	OCT	NOV	DEC
A11/A3.A4.D3	1020												
B15/A1.A4.A13.A16	1050												
A24/A2.A5.B4.C3	3150												
A12/A1.A4.C1	5420												
A12/A2.A6.A10	6420												
A24/A2.A6.C3	72 A0 (A2.53)												
A24/A2.A6.E6	7210												
A12/A1.A3.D1.E1.F1	92 A0												
A12/A1.A4.B3	92D0												
A12/A1.A4.B3.D1.E1.F1	934A (G2.1)												

	Dense vegetation and/or peak of biomass
	Sparse (younger) vegetation or minor green biomass
	Minor biomass with withered/dry plants (or part of plants)
	Bare soils (or water in A24) with remnants of withered/dry plants

Figure 1: LC Classes for GR2 test site- Seasonal Phenological characteristics

D5.2 VHR land cover maps

**LC Classes – Seasonal Water Coverage**

LCCS	HABITAT	JAN	FEB	MAR	APR	MAY	JUN	JUL	AGO	SEP	OCT	NOV	DEC
A11/A3.A4.D3	1020												
B15/A1.A4.A13.A16	1050												
A24/A2.A5.B4.C3	3150												
A12/A1.A4.C1	5420												
A12/A2.A6.A10	6420												
A24/A2.A6.C3	72 A0 (A2.53)												
A24/A2.A6.E6	7210												
A12/A1.A3.D1.E1.F1	92 A0												
A12/A1.A4.B3	92D0												
A12/A1.A4.B3.D1.E1.F1	934A (G2.1)												

	Water
	Wet or waterlogged soil
	Dry (at the surface) soil

Figure 2: LC Classes for GR2 test site- Seasonal Water Coverage

### **Class: A24/A2.A5.B4.C3**

**NODE: A24/ A2A5A16B4C3-A8A17B13**

Natural and semi-natural aquatic or regularly flooded vegetation/ Permanent wetlands

**+Environmental Attribute:**

- **WATER QUALITY:** Fresh water (R1)
- **CLIMATE:** Subtropics-Winter Rainfall (O3)
- **LITHOLOGY:** Calcareous rock-calcarenite (M233)
- **SOIL SURFACE ASPECT:** no data
- **SOIL SUBSURFACE ASPECT:** Histosols (N12-HS)

**+Technical Attribute:**

This class corresponds to the habitat: 3150

**Short habitat description:**

Aquatic natural areas – Sparse ((20-10) - 4%) Short Rooted Forbs On Waterlogged Soil.

Adjacent to habitats 7210 (A24/A2.A6.E5), 92D0 (A12/A1.A4.B3) and 934A (A12/A1.A4.B3.D1.E1.F1).

---

### **Class: A12/A1.A4.C1**

**NODE: A12/A1A4A11B3C1XXXXF1-A12B9**

Natural and semi-natural terrestrial vegetation/Open shrublands

**+Environmental Attribute:**

- **WATER QUALITY:** none
- **CLIMATE:** Subtropics-Winter Rainfall (O3)
- **LITHOLOGY:** Sedimentary rock (M2)
- **SOIL SURFACE ASPECT:** Stony 5-40% (N4)
- **SOIL SUBSURFACE ASPECT:**

**+Technical Attribute:** Cisto-Micromerietea (-etalia)

This class corresponds to the habitat: 5420



## D5.2 VHR land cover maps

### **Short habitat description:**

Terrestrial natural areas – Open ((70-60) - 40%) medium-high shrubland woody vegetation

Medium density (medium cover)

Two polygons of this habitat type both adjacent to habitats 934A (A12/A1.A4.B3.D1.E1.F1), 72A0 (A24/A2.A6.C3) and 1050 (B15/A1.A4.A13.A16) together with 92D0 (A12/A1.A4.B3) for the western polygon and 7210 (A24/A2.A6.E5) for the north-eastern one.

---

### **Class: A12/A2.A6.A10**

#### **NODE: A12/A2A6A10**

Natural and semi-natural terrestrial vegetation/ Natural grasslands

#### **+Environmental Attribute:**

- **WATER QUALITY:** none
- **CLIMATE:** Subtropics-Winter Rainfall (**O3**)
- **LITHOLOGY:** Sedimentary rock (**M2**)
- **SOIL SURFACE ASPECT:** Stony 5-40% (**N4**)
- **SOIL SUBSURFACE ASPECT:**

**+Technical Attribute:** *Scirpoides holoschoenus*

This class corresponds to the habitat: 6420

### **Short habitat description:**

Terrestrial natural areas – Interrupted open ((70-60) - 40%) perennial tall grassland

---

### **Class: A24/A2.A6.E5**

#### **NODE: A24/A2A6A12B4C2E5F1-B11E6**

Natural and semi-natural aquatic or regularly flooded vegetation/ Herbaceous.Graminoid.Perennial

#### **+Environmental Attribute:**

- **WATER QUALITY:** Fresh /Brackish water (**R1/R2**)

## D5.2 VHR land cover maps

- **CLIMATE:** Subtropics-Winter Rainfall (**O3**)
- **LITHOLOGY:** Calcareous rock-calcarenite (**M233**)
- **SOIL SURFACE ASPECT:** no data
- **SOIL SUBSURFACE ASPECT:** Histosols (**N12-HS**)

+**Technical Attribute:** *Cladium mariscus*

This class corresponds to the habitat: 7210

### **Short habitat description:**

Aquatic natural areas – herbaceous perennial vegetation of graminoid plants, composed mostly of fen sedges (height 1-2 m), colonising periodically inundated coastal areas and wet meadows with flooded or waterlogged soil for most of the year– This vegetation has a maximum of biomass (greyish-brownish green ) in June-September and less biomass with dry plants (most of the aerial part) in the rest of the year.

The background is water or waterlogged soil in winter (November-March), moist soil or waterlogged soil in spring, (moist) sand or mud in summer.

High density.

Two polygons of this habitat type both adjacent to habitat 72A0 (A24/A2.A6.C3) together with 3150 (A24/A2.A5.B4.C3) for the western polygon as well as 92A0 (A12/A1.A3.D1.E1.F1) and 5420 (A12/A1.A4.C1) for the eastern one.

---

## **Class: A24/A2.A6.C3**

### **NODE: A24/A2A6A12B4C3-B11**

Natural and semi-natural aquatic or regularly flooded vegetation/ Grasslands

### +**Environmental Attribute:**

- **WATER QUALITY:** Fresh /Brackish water (**R1/R2**)
- **CLIMATE:** Subtropics-Winter Rainfall (**O3**)
- **LITHOLOGY:** Calcareous rock-calcarenite (**M233**)
- **SOIL SURFACE ASPECT:** no data
- **SOIL SUBSURFACE ASPECT:** Histosols (**N12-HS**)

+**Technical Attribute:** *Phragmites australis*, *Bolboschoenus maritimus*

This class corresponds to the habitat: 72A0 (A2.53)

### **Short habitat description:**

Aquatic natural areas – Intertidal flats. Reed thickets (*Phragmites australis*). Closed Tall Grassland On Waterlogged Soil.

## D5.2 VHR land cover maps

The background is water or waterlogged soil in winter (November-March), moist soil or waterlogged soil in spring, (moist) sand or mud in summer. High density.

Two polygons of this habitat type both adjacent to habitat 7210 (A24/A2.A6.E5) and 5420 (A12/A1.A4.C1) together with 3150 (A24/A2.A5.B4.C3), 934A (A12/A1.A4.B3.D1.E1.F1) and 1020 (A11/A3.A4.D3) for the western polygon as well as 92A0 (A12/A1.A3.D1.E1.F1) for the eastern one.

---

### Class: A12/A1.A3.D1.E1.F1

**NODE: A12/A1A3A10B2XXD1E1F1-B7**

Natural and semi natural primarily terrestrial vegetation/ Deciduous Broadleaf Forests

**+Environmental Attribute:**

- **WATER QUALITY:** none
- **CLIMATE:** Subtropics-Winter Rainfall (**O3**)
- **LITHOLOGY:** Sedimentary rock (**M2**)
- **SOIL SURFACE ASPECT:** Stony 5-40% (**N4**)
- **SOIL SUBSURFACE ASPECT:** Histosols (**N12-HS**)

**+Technical Attribute:** *Salix alba*, *S. fragilis*, *Populus alba*, *Alnus* spp.

This class corresponds to the habitat: 92A0

**Short habitat description:**

Natural primarily terrestrial vegetation. Broadleaved Deciduous High Trees, Single Layer. Seasonally wet/eutrophic.Riparian *Salix*, *Alnus* and *Betula* woodland on deep wet or waterlogged soil. Softwood forests of *Salix alba* and *Populus alba*.

One polygon of this habitat type adjacent to habitat 7210 (A24/A2.A6.E5), 72A0 (A24/A2.A6.C3), 5420 (A12/A1.A4.C1), 1020 (A11/A3.A4.D3) and 1050(B15/A1.A4.A13.A16).

---

### Class: A12/A1.A4.B3

**NODE: A12/A1A4A11B3-A12B14**

Natural and semi natural primarily terrestrial vegetation/ Open shrublands.

**+Environmental Attribute:**

- **WATER QUALITY:** none
- **CLIMATE:** Subtropics-Winter Rainfall (**O3**)

## D5.2 VHR land cover maps

- **LITHOLOGY:** Sedimentary rock (**M2**)
- **SOIL SURFACE ASPECT:** Stony 5-40% (**N4**)
- **SOIL SUBSURFACE ASPECT:**

+**Technical Attribute:** *Nerium oleander*, *Tamarix* spp.

This class corresponds to the habitat: 92D0

### **Short habitat description:**

Natural primarily terrestrial vegetation. Open ((70-60) - 40%) medium to high shrubs (shrubland) with *Tamarix hampeana*, *Tamarix parviflora*, *Tamarix smyrnensis*, *Tamarix tetrandra* as well as *Nerium oleander*, *Vitex agnus-castus* etc. on dry soils.

One polygon of this habitat type adjacent to habitat 72A0 (A24/A2.A6.C3), 5420 (A12/A1.A4.C1), 3150 (A24/A2.A5.B4.C3) and 934A (A12/A1.A4.B3.D1.E1.F1).

---

## **Class: A12/A1.A4.B3.D1.E1.F1**

### ***NODE: A12/A1A4A10B3XXD1E1F1-B8***

Natural and semi natural primarily terrestrial vegetation/ Closed shrublands

### +**Environmental Attribute:**

- **WATER QUALITY:** none
- **CLIMATE:** Subtropics-Winter Rainfall (**O3**)
- **LITHOLOGY:** Sedimentary rock (**M2**)
- **SOIL SURFACE ASPECT:** Stony 5-40% (**N4**)
- **SOIL SUBSURFACE ASPECT:**

+**Technical Attribute:** *Quercus coccifera*

This class corresponds to the habitat: 934A

### **Short habitat description:**

Natural primarily terrestrial vegetation. Broadleaved Evergreen High Thicket, Single Layer.

Polygons of this habitat type adjacent to habitats 72A0 (A24/A2.A6.C3), 3150 (A24/A2.A5.B4.C3), 1020 (A11/A3.A4.D3) and 1050 (B15/A1.A4.A13.A16) at the western part of the site as well as 5420 (A12/A1.A4.C1) and 1020 (A11/A3.A4.D3) at the eastern part.

**Class: A11/A3.A4.D3**

**NODE: A11/A3A4B1XXC2D3-B4C3C7C19D5**

Cultivated and managed terrestrial areas/ Cropland

**+Environmental Attribute:**

- **WATER QUALITY:** none
- **CLIMATE:** Subtropics-Winter Rainfall (O3)
- **LITHOLOGY:**
- **SOIL SURFACE ASPECT:**
- **SOIL SUBSURFACE ASPECT:**

**+Technical Attribute:**

This class corresponds to the habitat: 1020

**Short habitat description:**

Cultivated and managed terrestrial areas. Intensive unmixed crops. Sprinkler Irrigated Graminoid Crop(s) (One Additional Crop) ( Herbaceous Terrestrial Crop Sequentially).

Two polygons of this habitat type both adjacent to habitats 934A (A12/A1.A4.B3.D1.E1.F1) while the eastern one is also adjacent to 72A0 (A24/A2.A6.C3) and 92A0 ((A12/A1.A3.D1.E1.F1).

---

**Class: B15/ A1.A4.A13.A16**

**NODE: B15/A1A4A13A16**

Artificial surfaces and associated areas/ Urban and built-up

**+Environmental Attribute:**

- **WATER QUALITY:** none
- **CLIMATE:** Subtropics-Winter Rainfall (O3)
- **LITHOLOGY:**
- **SOIL SURFACE ASPECT: SOIL SUBSURFACE ASPECT:**

**+Technical Attribute:**

## D5.2 VHR land cover maps

This class corresponds to the habitat: 1050

**Short habitat description:**

Artificial surfaces and associated areas. Low Density Urban Area(s)

Two polygons of this habitat type both adjacent to habitats 934A (A12/A1.A4.B3.D1.E1.F1) and 5420 (A12/A1.A4.C1) together with 92A0 (A12/A1.A3.D1.E1.F1) for the eastern polygon.

---

**B2.3 GR3 site**

**LC Classes – Seasonal Phenological characteristics**

LCCS	HABITAT	JAN	FEB	MAR	APR	MAY	JUN	JUL	AGO	SEP	OCT	NOV	DEC
A11/A3.A4.D3	1020												
A11/A1.B1.C1.D1	1021												
B15/A1.A4.A13.A16	1050												
A24/A2.A5.F2	3280												
A12/A2.A5.B4	5150 (E5.3)												
A12/ A1.A4.D1.E2.F1	5340 (F6.2)												
A12/A1.A4.A11	8210												
A12/A1.A3.D1.E1.F1	92 A0												
A12/A1.A3.D1.E2	9250												
A12/A1.A3.D1.E2.F1	92C0												
A12/A1.A4.B3.D1.E1.F1	934A (G2.1)												

	Dense vegetation and/or peak of biomass
	Sparse (younger) vegetation or minor green biomass
	Minor biomass with withered/dry plants (or part of plants)
	Bare soils (or water in A24) with remnants of withered/dry plants

Figure 1: LC Classes for GR3 test site- Seasonal Phenological characteristics

D5.2 VHR land cover maps

**LC Classes – Seasonal Water Coverage**

LCCS	HABITAT	JAN	FEB	MAR	APR	MAY	JUN	JUL	AGO	SEP	OCT	NOV	DEC
A11/A3.A4.D3	1020												
A11/A1.B1.C1.D1	1021												
B15/A1.A4.A13.A16	1050												
A24/A2.A5.F2	3280												
A12/A2.A5.B4	5150 (E5.3)												
A12/ A1.A4.D1.E2.F1	5340 (F6.2)												
A12/A1.A4.A11	8210												
A12/A1.A3.D1.E1.F1	92 A0												
A12/A1.A3.D1.E2	9250												
A12/A1.A3.D1.E2.F1	92C0												
A12/A1.A4.B3.D1.E1.F1	934A (G2.1)												

	Water
	Wet or waterlogged soil
	Dry (at the surface) soil

Figure 2: LC Classes for GR3 test site- Seasonal Water Coverage



### **Class: A24/A2.A5.F2**

**NODE: A24/A2A5A13B4C3XXXXF2F5F10G2F1.E30**

Natural and semi natural aquatic or regularly flooded vegetation / Inland marshes

**+Environmental Attribute:**

- **WATER QUALITY:** Fresh water (R1)
- **CLIMATE:** Subtropics-Winter Rainfall (O3)
- **LITHOLOGY:** Calcareous rock-calcarenite (M233)
- **SOIL SURFACE ASPECT:** no data
- **SOIL SUBSURFACE ASPECT:** Histosols (N12-HS)

**+Technical Attribute:** *Paspalo-Agrostidion*

This class corresponds to the habitat: 3280

**Short habitat description:**

Natural aquatic or regularly flooded vegetation. Natural waterbodies. Perennial open (40 - (20-10)%) tall rooted forbs with low emergents on waterlogged soil.

Presence of sand or outcropping calcareous rocks as background.

Distributed next to the riverline, in a band of variable width, from a few to several hundred meters, based on the geomorphology of the belt.

Adjacent to 92C0 (A12/A1.A3.D1.E2.F1).

---

### **Class: A12/A2.A5.B4**

**NODE: A2A5A11B4-A12B11**

Natural and semi-natural terrestrial vegetation/Moors and heathland

**+Environmental Attribute:**

- **WATER QUALITY:** none
  - **CLIMATE:** Subtropics-Winter Rainfall (O3)
- BIO\_SOS FP7-SPACE-2010-1 GA 263435

## D5.2 VHR land cover maps

- **LITHOLOGY:** Sedimentary rock (**M2**)
- **SOIL SURFACE ASPECT:** Stony 5-40% (**N4**)
- **SOIL SUBSURFACE ASPECT:**

+**Technical Attribute:** *Pteridium aquilinum*

This class corresponds to the habitat: 5150 (E5.3)

### **Short habitat description:**

Terrestrial natural areas – Open ((70-60) - 40%) Tall Forbs. *Pteridium aquilinum* fields

Medium density (medium cover)

This habitat type covers a very small area in this site and is surrounded by habitat 934A (A12/A1.A4.B3.D1.E1.F1).

---

## **Class: A12/A1.A4.D1.E2.F1**

**NODE: A12/ A1A4A11B3XXD1E2F1-A12B9**

Natural and semi-natural terrestrial vegetation/ Sclerophyllous vegetation

+**Environmental Attribute:**

- **WATER QUALITY:** none
- **CLIMATE:** Subtropics-Winter Rainfall (**O3**)
- **LITHOLOGY:** Calcareous rock-calcarenite (**M233**)
- **SOIL SURFACE ASPECT:** Stony 5-40% (**N4**)
- **SOIL SUBSURFACE ASPECT:** Leptosols

+**Technical Attribute:**

This class corresponds to the habitat: 5340 (F6.2)

### **Short habitat description:**

Terrestrial natural areas –woody vegetation characterized by broadleaved deciduous ((70-60) - 40%) medium-high sclerophyllous shrubs - height 0,8-2 m.

High density (high cover)

## D5.2 VHR land cover maps

Twelve different polygons of this habitat type in this site of which the four northern ones adjacent only to habitat 9250 (A12/A1.A3.D1.E2) while the others adjacent mainly to habitat 934A (A12/A1.A4.B3.D1.E1.F1) together with 92C0 (A12/A1.A3.D1.E2.F1) for the north-eastern polygon, 8210 (A12/A1.A4.A11) for the western ones, 1020 (A11/A3.A4.D3) for the southern one and 1050 (B15/A1.A4.A13.A16) for the south-eastern one.

---

### Class: A12/A1.A4.A11

**NODE: A12/ A1.A4.A11.B3.XX.XX.XX.F1**

Natural and semi-natural terrestrial vegetation/ Sparsely vegetated areas

**+Environmental Attribute:**

- **WATER QUALITY:** none
- **CLIMATE:** Subtropics-Winter Rainfall (O3)
- **LITHOLOGY:** Calcareous rock (M230)
- **SOIL SURFACE ASPECT:** Very Stony 40-80% (N5)
- **SOIL SUBSURFACE ASPECT:** Calcisols (N1106)

**+Technical Attribute:** *Potentilla caulecens*

This class corresponds to the habitat: 8210

**Short habitat description:**

Terrestrial natural areas –Sparse perennial short forbs

There are two polygons of this habitat type at the eastern part of the site, both adjacent to habitat 934A (A12/A1.A4.B3.D1.E1.F1) and 92C0 (A12/A1.A3.D1.E2.F1). There are also seven polygons of this habitat type at the western – central western part of the site, two of them are adjacent to habitat 934A (A12/A1.A4.B3.D1.E1.F1) together with habitat 5340 (A12/A1.A4.D1.E2.F1), two are surrounded by 5340, two are surrounded by 934A and one is adjacent to 934A and 92C0. At the south-east part of the site there are four polygons of this habitat type, two of them are surrounded by 934A and two are adjacent to 934A and 1021(A11/A1.B1.C1.D1).

---

### Class: A12/A1.A3.D1.E1.F1

**NODE: A12/A1A3A10B2XXD1E1F1-B7**

Natural and semi natural primarily terrestrial vegetation/ Deciduous Broadleaf Forests

## D5.2 VHR land cover maps

### +Environmental Attribute:

- **WATER QUALITY:** none
- **CLIMATE:** Subtropics-Winter Rainfall (**O3**)
- **LITHOLOGY:** Sedimentary rock (**M2**)
- **SOIL SURFACE ASPECT:** Stony 5-40% (**N4**)
- **SOIL SUBSURFACE ASPECT:** Histosols (**N12-HS**)

+Technical Attribute: *Salix alba*, *S. fragilis*, *Populus alba*, *Alnus* spp.

This class corresponds to the habitat: 92A0

### Short habitat description:

Natural primarily terrestrial vegetation. Broadleaved Deciduous High Trees, Single Layer. Seasonally wet/eutrophic. Riparian *Salix*, *Alnus* and *Betula* woodland on deep wet or waterlogged soil. Softwood forests of *Salix alba* and *Populus alba*.

This habitat type covers one polygon in this site and is surrounded by habitat 934A (A12/A1.A4.B3.D1.E1.F1).

---

## Class: A12/A1.A3.D1.E2.F1

### **NODE: A12/A1A3A10B2XXD1E2F1-B5**

Natural and semi natural primarily terrestrial vegetation/ Deciduous Broadleaf Forests.

### +Environmental Attribute:

- **WATER QUALITY:** none
- **CLIMATE:** Subtropics-Winter Rainfall (**O3**)
- **LITHOLOGY:** Sedimentary rock (**M230**)
- **SOIL SURFACE ASPECT:** Very Stony 40-80% (**N5**)
- **SOIL SUBSURFACE ASPECT:**

+Technical Attribute: *Platanus orientalis*

This class corresponds to the habitat: 92C0

### Short habitat description:

Natural primarily terrestrial vegetation. Broadleaved deciduous high trees with *Platanus orientalis* on moist soils. Single layer.

All polygons of this habitat type are adjacent to 934A (A12/A1.A4.B3.D1.E1.F1) and 3280 (A24/A2.A5.F2).

## Class: A12/A1.A3.D1.E2

**NODE: A12/A1A3A10B2D1E2/B6E4**

Natural and semi natural primarily terrestrial vegetation/ Deciduous Broadleaf Forests

**+Environmental Attribute:**

- **WATER QUALITY:** none
- **CLIMATE:** Subtropics-Winter Rainfall (O3)
- **LITHOLOGY:** Calcareous rock (M230)
- **SOIL SURFACE ASPECT:** Stony 5-40% (N4)
- **SOIL SUBSURFACE ASPECT:**

**+Technical Attribute:** *Quercus trojana*

This class corresponds to the habitat: 9250

**Short habitat description:**

Natural primarily terrestrial vegetation. Semi-deciduous closed medium high trees.

This vegetation is adjacent with habitats 934A (A12/A1.A4.B3.D1.E1.F1) and 5340 (A1.A4.D1.E2.F1)

---

## Class: A12/A1.A4.B3.D1.E1.F1

**NODE: A12/A1A4A10B3XXD1E1F1-B8**

Natural and semi natural primarily terrestrial vegetation/ Closed shrublands

**+Environmental Attribute:**

- **WATER QUALITY:** none
- **CLIMATE:** Subtropics-Winter Rainfall (O3)
- **LITHOLOGY:** Sedimentary rock (M2)
- **SOIL SURFACE ASPECT:** Stony 5-40% (N4)
- **SOIL SUBSURFACE ASPECT:**

## D5.2 VHR land cover maps

**+Technical Attribute:** *Quercus coccifera*

This class corresponds to the habitat: 934A (G2.1)

**Short habitat description:**

Natural primarily terrestrial vegetation. Broadleaved Evergreen High Thicket, Single Layer.

This habitat type covers a large part of the site and it is adjacent to 92C0 (A12/A1.A3.D1.E2.F1), 5340 (A12/A1.A4.D1.E2.F1), 8210 (A12/A1.A4.A11), 1020(A11/A3.A4.D3) and 1021 (A11/A1.B1.C1.D1). It is also surrounding habitat 92A0 (A12/A1.A3.D1.E1.F1).

---

### **Class: A11/A3.A4.D3**

**NODE: A11/A3A4B1XXC2D3-B4C3C7C19D5**

Cultivated and managed terrestrial areas/ Cropland

**+Environmental Attribute:**

- **WATER QUALITY:** none
- **CLIMATE:** Subtropics-Winter Rainfall (O3)
- **LITHOLOGY:**
- **SOIL SURFACE ASPECT:**
- **SOIL SUBSURFACE ASPECT:**

**+Technical Attribute:**

This class corresponds to the habitat: 1020

**Short habitat description:**

Cultivated and managed terrestrial areas. Intensive unmixed crops. Sprinkler Irrigated Graminoid Crop(s) (One Additional Crop) ( Herbaceous Terrestrial Crop Sequentially).

There are two polygons of this habitat type in this site. The eastern one is surrounded by habitat 934A (A12/A1.A4.B3.D1.E1.F1) while the southern one is adjacent to habitats 934A, 5340 (A12/A1.A4.D1.E2.F1), 8210 (A12/A1.A4.A11), 1050 (B15/A1.A4.A13.A16) and 1021 (A11/A1.B1.C1.D1).

---

### **Class: A11/A1.B1.C1.D1**

**NODE: A11/A1B1XXC1D1-B4-W8**

Cultivated and managed terrestrial areas/ Cropland

**+Environmental Attribute:**

- **WATER QUALITY:** none
- **CLIMATE:** Subtropics-Winter Rainfall (O3)
- **LITHOLOGY:**
- **SOIL SURFACE ASPECT:**
- **SOIL SUBSURFACE ASPECT:**

**+Technical Attribute:**

This class corresponds to the habitat: 1021

**Short habitat description:**

Cultivated and managed terrestrial areas. Land principally occupied by agriculture, with significant areas of natural vegetation. Rainfed Tree Crop(s)

Crop Cover: Orchard(s).

There are two polygons of this habitat type in this site. The eastern one is surrounded by habitat 934A (A12/A1.A4.B3.D1.E1.F1) while the southern one is adjacent to habitats 934A, 8210 (A12/A1.A4.A11), 1050 (B15/A1.A4.A13.A16) and 1020 (A11/A3.A4.D3).

---

**Class: B15/ A1.A4.A13.A16**

**NODE: B15/A1A4A13A16**

Artificial surfaces and associated areas/ Urban and built-up

**+Environmental Attribute:**

- **WATER QUALITY:** none
- **CLIMATE:** Subtropics-Winter Rainfall (O3)
- **LITHOLOGY:**
- **SOIL SURFACE ASPECT: SOIL SUBSURFACE ASPECT:**

**+Technical Attribute:**

This class corresponds to the habitat: 1050

## D5.2 VHR land cover maps

### **Short habitat description:**

Artificial surfaces and associated areas. Low Density Urban Area(s)

One polygon of this habitat type in this site, adjacent to habitats 8210 (A12/A1.A4.A11), 1020 (A11/A3.A4.D3) and 1021 (A11/A1.B1.C1.D1).

---



### 3. References

- Adams, J.B., Sabol, D.E., Kapos, V., Filho, R.A., Roberts, D.A., Smith, M.O. and Gillespie, A.R. (1995). Classification of multispectral images based on endmember fractions: Application to land-cover in the Brazilian Amazon. *Remote Sensing of Environment*, 52, 137-154.
- Armston, J., Denham, R., Danaher, T., Scarth, P. and Moffiet, T. 2009. Prediction and validation of foliage projective cover from Landsat-5 TM and Landsat-7 ETM+ imagery for Queensland, Australia. *Journal of Applied Remote Sensing*, 3: 033540.
- Allen, J.F. (1983). *Maintaining knowledge about temporal intervals*. In: *Communications of the ACM*. 26 November 1983. ACM Press. pp. 832–843, ISSN 0001-0782
- Baraldi A., Puzzolo V., Blonda P., Bruzzone L., Tarantino C., Sept. 2006. Automatic spectral rule-based preliminary mapping of calibrated Landsat TM and ETM+ images, *IEEE Trans. Geosci. Remote Sensing*, vol. 44, no. 9, pp. 2563-2586
- Baraldi A., Durieux L., Simonetti D., Conchedda G., Holecz F., Blonda P., March 2010. Automatic spectral rule-based preliminary classification of radiometrically calibrated SPOT-4/-5/IRS, AVHRR/MSG, AATSR, IKONOS/Quickbird/OrbView/GeoEye and DMC/SPOT-1/-2 imagery – Part I: System design and implementation, *IEEE Trans. Geosci. Remote Sensing*, vol. 48, no. 3, pp. 1299 – 1325
- Binaghi, E., P.A. Brivio, P. Ghezzi and A. Rampini, 1999. A fuzzy set-based accuracy assessment of soft classification. *Pattern Recognition Letters* 20: 935-948.
- Bunce, R.G.H. Bogers, M.M. B. Roche, P. Walczak, M., Geijzendorffer, I.R. and Jongman, R.H.G. (2011). *Manual for Habitat and Vegetation Surveillance and Monitoring: Temperate, Mediterranean and Desert Biomes*. First edition. Wageningen, Alterra report 2154 . 106 pp.
- Bunce, R.G.H., Metzger, M.J., Jongman, R.H.G., Brandt, J., Blust, G. de; Elena-Rossello, R., Groom, G.B., Halada, L., Hofer, G., Howard, D.C., Kovár, P., Múcher, C.A., Padoa-Schioppa, E., Paelinx, D., Palo, A., Pérez-Soba, M., Ramos, I.L., Roche, P., Skånes, H. and Wrbka, T. (2008). A Standardized Procedure for Surveillance and Monitoring European Habitats and provision of spatial data. *Landscape Ecology*, 23:11-25.
- Bunting, P. and Lucas, R.M. (2006). The delineation of tree crowns within CASI data of Australian mixed species woodlands, *Remote Sensing of Environment*, 101, 230-248.
- Clementini, E., Di Felice, P., van Oosterom, P. (1993). A small set of formal topological relationships suitable for end-user interaction. *Lecture notes in Computer Sciences* 692, 277-295.
- Cho, H.J., Kirui, P. and Natarajan, H. (2008). Test of multi-spectral vegetation index for floating and canopy forming submerged vegetation, *Int. J. Environ. Res. Public Health*, 5, 477-483.
- Congalton, R.G. (1991), A review of assessing the accuracy of classifications of remotely sensed data. *Remote Sensing of Environment* 37 (1): 35-46.
- Egenhofer, M.J., Herring, J.R. (1991). *Categorizing binary topological relations between regions, lines, and points in geographic databases*. Technical report, Department of surveying Engineering), Orono-ME, 28 p.
- Egenhofer, M.J., Mark, D. M. (1995). *Naïve geography*. National Center for Geographic Information and Analysis. Report 95-8, 16 p.

## D5.2 VHR land cover maps

- Fitzgerald, R.W. and Lees, B.G. (1994). Assessing the classification accuracy of multi-resource remote sensing data. *Remote Sensing of Environment*, 47, 362-368.
- Fonseca, F.T., Egenhofer, M.J., Agouris, P., Câmara, G. (2002). Using ontologies for Integrated Geographic Information Systems. *Transactions in GIS* 6(3), 231-257.
- Foody, G.M. (1996). Approaches for the production and evaluation of fuzzy land cover classifications from remotely-sensed data, *International Journal of Remote Sensing* Volume 17, Issue 7, 1996, Pages 1317-1340
- Foody, G.M. (2002), Status of land cover classification accuracy assessment. *Remote Sensing of Environment* 80 (1): 185-201.
- Foody, G.M. (2011). Classification Accuracy Assessment. *IEEE Geoscience and Remote Sensing Society Newsletter*, June.
- Govender, M., K. Chetty, and H. Bulcock, 2006. A review of hyperspectral remote sensing and its application in vegetation and water resource studies. *Water SA* 33 (2): 145-151.
- Grove, S. (1999). Knowledge based interpretation of multisensor and multitemporal remote sensing images. *International Archives of Photogrammetry and Remote Sensing* images, vol. 32., Part 7-4-3 W6, Valladolid, Spain, 3-4 June.
- Gruber, T.R. (1995). Toward principles for the design of ontologies used for knowledge sharing. *International Journal of Human Computer Studies*, 23 p.
- Gruber, T.R. (2009) Ontology, In Liu, L. and Özsu, M.T. (Eds.), *Encyclopedia of Database Systems*, Springer-Verlag, 2009, 1963-1965.
- Hakvoort, H, De Haan, J., Jordan, R., Vos, R., Peters, S. and Rijkeboer, M. (2002). Towards airborne remote sensing of water quality in the Netherlands-validation and error analysis. *J. Photogr. Remote Sens.* 57 171-183.
- Hay, G. J., Dubi, P., Bouchard, A., Marceau, D. J. (2002). A scale-space primer for exploring and quantifying complex landscapes. *Ecological Modelling* 153 (1-2), 27-49.
- Jongman, R. H.G. (Ed.), (1996). Ecological and Landscape consequences of land use Change in Europe. *Proceedings of the First ECNC Seminar on L and Use Change and its Ecological Consequences*, Tilburg, the Netherlands, 16–18 February 1995. ECNC Publication Series on Man and Nature, Volume 2, November 1996. ISBN 90-802482-1-5.
- Jongman, R.H.G. and Bunce, R.G.H. 2000. Landscape classification, scales ad biodiversity in Europe. In Ü Mander and R.H.G. Jongman (Eds). *Consequences of Land use change in Europe* pp 11-38.
- Lucas, R.M., Bunting, P., Paterson, M. and Chisholm, M. (2008). Classification of Australian Forest Communities Using Aerial Photography, CASI and HyMap Data. *Remote Sensing of Environment*, 112, 2088-2103.
- Lucas, R.M., Medcalf, K., Brown, A., Bunting, P., Breyer, J., Clewley, D., Keyworth, S. and Blackmore, P. (2011). Updating the Phase 1 habitat map of Wales, UK, using satellite sensor data. *International Journal of Photogrammetry and Remote Sensing*, 66(1), 81–102.
- Luckman, A., Baker, J, Honzak, M., Lucas, R. (1998). Tropical forest biomass density estimation using JERS-1 SAR: Seasonal variation, confidence limits and application to image mosaics. *Remote Sensing of Environment*, 63, 126-139.

Lüscher, P., Burghardt, D., Weibel, R. (2007). Ontology-driven enrichment of spatial databases. 10<sup>th</sup> ICA Workshop on generalization and Multiple Representation, August 2007, Moscow, Russia, 13 p.

Mascardi, V., Cordi, V., Rosso, P. (2006). A comparison of upper ontologies. Technical report DIDI-TR-06-21). Span, 15 p.

Mócher, C.A. (2009). Geo-spatial modelling and monitoring of European landscapes and habitats using remote sensing and field surveys. PhD thesis Wageningen University, Wageningen, The Netherlands, ISBN 978-90-8585-453-1, 269 pp.

Naesset, E. (1996). Conditional tau coefficient for assessment of producer's accuracy of classified remotely sensed data. *ISPRS Journal of Photogrammetry and Remote Sensing*, 51, 91-98.

Pontius, R.G. and M.L. Cheuk (2006). A generalized cross-tabulation matrix to compare soft-classified maps at multiple resolutions. *International Journal of Geographical Information Science* 20(1): 1-30.

Randell, D., Cui, Z., Cohn, A. (1992). A spatial logic based on regions and connection. *Proceedings of the 3rd International Conference on Knowledge Representation and Reasoning*, 165-176.

Raskin, R.G., Pan, M.J. (2005). Knowledge representation in the semantic web for Earth and environmental terminology (SWEET). *Computers & Geosciences* 31, 1119-1125.

Radoux, J., Bogaert, P., Fasbender, D. and Defourney, P. (2010). Thematic accuracy assessment of geographic object-based image classification. *International Journal of Geographic Information Science iFirst*, 1-17.

Saatchi, S., Despain, D., Halligan, K. & Crabtree, R.L. (2007). Estimation of Forest Fuel Load From Radar Remote Sensing. *IEEE Transactions on Geoscience and Remote Sensing* 45:1726-1740.

SIAM™ documentation, on BIO\_SOS ftp site.

Stehman, S.V. (1997), Selecting and interpreting measures of thematic classification accuracy. *Remote Sensing of Environment* 62 (1): 77-89.

Steininger, M.K. 2000. Satellite estimation of tropical secondary forest above-ground biomass: data from Brazil and Bolivia. *International Journal of Remote Sensing*, 21, 1139-1157.

Tripathi, A., Babaie, H.A. (2008). Developing a modular hydrogeology ontology by extending the SWEET upper-level ontologies. *Computers & Geosciences* 34, 1022-1033.

Wamunyima, S. (2005). Estimating fresh grass biomass at landscape level using hyperspectral remote sensing. Ph.D. thesis, International Institute for Geo-information Science and Earth Observation, Enschede, the Netherlands. 61 pp.

Wu, J., David, J.L. (2002). A spatially explicit hierarchical approach to modeling complex ecological systems: Theory and applications. *Ecol. Model.* 153 (1-2), 7-26.

Wu, J., Marceau, D. (2002). Modeling complex ecological systems: An introduction. *Ecol. Model.* 153 (1-2), 1-6.